

Dynamics and Control of Open Quantum Systems

Mazyar Mirrahimi¹ and Pierre Rouchon^{2 3}

November, 2021

¹Quantic Team, INRIA Paris, 75012 Paris, France.

²Centre Automatique et Systèmes (CAS), MINES ParisTech, Université PSL, 75006 Paris, France.

³Quantic Team, INRIA Paris, 75012 Paris, France.

Contents

1	Spins and springs	7
1.1	Quantum harmonic oscillator: spring models	7
1.1.1	Quantization of classical harmonic oscillator	7
1.1.2	Spectral decomposition based on annihilation/creation operators	8
1.1.3	Glauber displacement operator and coherent states	9
1.2	Qubit: spin-half models	11
1.2.1	Schrödinger equation and Pauli matrices	11
1.2.2	Bloch sphere representation	13
1.3	Composite spin-spring systems	13
1.3.1	Jaynes-Cummings Hamiltonians and propagators	14
1.3.2	Laser manipulation of a trapped ion	16
2	Open-loop control of spins and springs	19
2.1	Resonant control, rotating wave approximation	19
2.1.1	Multi-frequency averaging	19
2.1.2	Approximation recipes	22
2.1.3	Approximation lemma	23
2.1.4	Qubits and Rabi oscillations	24
2.1.5	Λ -systems and Raman transition	26
2.1.6	Jaynes-Cummings model	29
2.1.7	Single trapped ion and Law-Eberly method	32
2.2	Adiabatic control	35
2.2.1	Time-adiabatic approximation without gap conditions	35
2.2.2	Adiabatic motion on the Bloch sphere	36
2.2.3	Stimulated Raman Adiabatic Passage (STIRAP)	37
2.2.4	Chirped pulse for a 2-level system	38
2.3	Optimal control	40
2.3.1	First order stationary condition	40
2.3.2	Monotone numerical scheme	41
3	Quantum Measurement and discrete-time open systems	43
3.1	Quantum measurement	43
3.1.1	Projective measurement	44
3.1.2	Positive Operator Valued Measure (POVM)	45
3.1.3	Quantum Non-Demolition (QND) measurement	46
3.1.4	Stochastic process attached to a POVM	47

3.2	Example of the photon-box	48
3.2.1	Markov chain model	48
3.2.2	Jaynes-Cummings propagator	50
3.2.3	Resonant case	51
3.2.4	Dispersive case	52
3.2.5	QND measurements: open-loop asymptotic behavior	53
3.2.6	QND measurements and quantum-state feedback	55
3.2.7	Measurement uncertainties and Bayesian quantum filtering	57
3.2.8	Relaxation as an unread measurement	59
3.3	Structure of discrete-time open quantum systems	61
3.3.1	Markov models	61
3.3.2	Kraus and unital maps	62
3.3.3	Quantum filtering	63
4	Continuous-time open systems	65
4.1	Lindblad master equation	65
4.2	Driven and damped quantum harmonic oscillator	66
4.2.1	Classical ordinary differential equations	66
4.2.2	Quantum master equation	67
4.2.3	Zero temperature case: $n_{\text{th}} = 0$	68
4.2.4	Wigner function and quantum Fokker-Planck equation	69
4.3	Adiabatic elimination of a low-Q harmonic oscillator	72
4.4	Autonomous stabilization of a cat-qubit	76
4.4.1	The classical analysis	76
4.4.2	The quantum analysis	78
4.5	Stochastic master equations	80
4.5.1	Diffusive case	80
4.5.2	Jump case	82
4.5.3	Mixed diffusive/jump case	83
4.6	QND measurement of a qubit and asymptotic behavior	84
A	Basic Quantum notions	87
A.1	Bra, Ket and operators	87
A.2	Schrödinger equation	88
A.3	Composite systems and tensor product	89
A.4	Density operator	91
A.5	Observables and measurement	92
A.6	Pauli Matrices	93
B	Operator spaces	95
C	Linear quantum operations	99
D	Single-frequency Averaging	101
E	Pontryaguin Maximum Principe	105
F	Markov chains, martingales and convergence theorems	107

G Model reduction and singular perturbations	109
G.1 Attractive invariant manifold	109
G.2 Tikhonov normal form	110
G.3 Coordinate free setting	111
G.4 Approximation based on center manifold techniques	112
H Quantum Markovian feedback	115
H.1 Discrete-time systems	115
H.2 Continuous-time diffusive systems	116
H.2.1 Single-Input/Single-Output case (SISO)	116
H.2.2 Multi-Input/Multi-Output case (MIMO)	117

Chapter 1

Spins and springs

Through this chapter, we will overview some of the basic properties of a quantum harmonic oscillator and a half spin as central quantum systems for many experimental realizations of quantum information proposals such as trapped ions, nano-photonics, cavity quantum electrodynamics and quantum superconducting circuits. For a more thorough exposure of mathematical formulae attached to such systems we invite the reader to see e.g. [11].

1.1 Quantum harmonic oscillator: spring models

1.1.1 Quantization of classical harmonic oscillator

We start with the case of a classical harmonic oscillator of frequency $\omega > 0$, $\frac{d^2}{dt^2}x = -\omega^2x$. In the case of a mechanical oscillator, this could represent the periodic motion of a particle of mass m in a quadratic potential $V(x) = m\omega^2x^2/2$, or in the case of an electrical one, it could represent the oscillation between the voltage across the capacitance and the current through the inductance in an LC circuit (the frequency ω being given by $1/\sqrt{LC}$). A generic Hamiltonian formulation of this classical harmonic oscillator, is as follows:

$$\frac{d}{dt}x = \omega p = \frac{\partial H}{\partial p}, \quad \frac{d}{dt}p = -\omega x = -\frac{\partial H}{\partial x}$$

with the classical Hamiltonian $H(x, p) = \frac{\omega}{2}(p^2 + x^2)$. Note that, in this formulation, we have intentionally rendered the position and momentum coordinates x and p dimensionless, so as to keep it generic with respect to the choice of the physical system.

The correspondence principle yields the following quantization: H becomes an operator \mathbf{H} on the function of $x \in \mathbb{R}$ with complex values. The classical state $(x(t), p(t))$ is replaced by the quantum state $|\psi\rangle_t$ associated to the function $\psi(x, t) \in \mathbb{C}$. At each t , $\mathbb{R} \ni x \mapsto \psi(x, t)$ is measurable and $\int_{\mathbb{R}} |\psi(x, t)|^2 dx = 1$: for each t , $|\psi\rangle_t \in L^2(\mathbb{R}, \mathbb{C})$.

The Hamiltonian \mathbf{H} is derived from the classical one H by replacing the position coordinate x by the Hermitian operator $\mathbf{X} \equiv x$ (multiplication by x) and the momentum coordinate p by the Hermitian operator $\mathbf{P} \equiv -i\frac{\partial}{\partial x}$:

$$\mathbf{H} = \frac{\omega}{2}(\mathbf{P}^2 + \mathbf{X}^2) \equiv -\frac{\omega}{2}\frac{\partial^2}{\partial x^2} + \frac{\omega}{2}x^2.$$

Through out these lecture notes, we will take $\hbar = 1$ and thus all Hamiltonians encountered in the sequel are homogeneous to the inverse of a time, i.e. to a frequency, as it is the case for \mathbf{H} here above.

This Hamiltonian is defined on the Hilbert space $L^2(\mathbb{R}, \mathbb{C})$ with its domain given by the Sobolev space $H^2(\mathbb{R}, \mathbb{C})$. The Hamilton ordinary differential equations are replaced by the Schrödinger equation, $\frac{d}{dt}|\psi\rangle = -i\mathbf{H}|\psi\rangle$, a partial differential equation describing the dynamics of $\psi(x, t)$ from its initial condition $(\psi(x, 0))_{x \in \mathbb{R}}$:

$$i \frac{\partial \psi}{\partial t}(x, t) = -\frac{\omega}{2} \frac{\partial^2 \psi}{\partial x^2}(x, t) + \frac{\omega}{2} x^2 \psi(x, t), \quad x \in \mathbb{R}.$$

The average position is given by $\langle \mathbf{X} \rangle_t = \langle \psi | \mathbf{X} | \psi \rangle = \int_{-\infty}^{+\infty} x |\psi|^2 dx$. Similarly, the average momentum is given by $\langle \mathbf{P} \rangle_t = \langle \psi | \mathbf{P} | \psi \rangle = -i \int_{-\infty}^{+\infty} \psi^* \frac{\partial \psi}{\partial x} dx$, (real quantity via an integration by part).

1.1.2 Spectral decomposition based on annihilation/creation operators

The Hamiltonian $\mathbf{H} = -\frac{\omega}{2} \frac{\partial^2}{\partial x^2} + \frac{\omega}{2} x^2$ admits a discrete spectrum corresponding to the eigenvalues

$$E_n = \omega(n + 1/2), \quad n = 0, 1, 2, \dots$$

associated to orthonormal eigenfunctions

$$\psi_n(x) = \left(\frac{1}{\pi}\right)^{1/4} \frac{1}{\sqrt{2^n n!}} e^{-x^2/2} H_n(x)$$

where $H_n(x) = (-1)^n e^{x^2} \frac{d^n}{dx^n} e^{-x^2}$ is the Hermite polynomial of order n . While this spectral decomposition could be found through brute-force computations, here we introduce the more elegant proof applying the so-called annihilation/creation operators.

Indeed, as it will be clear through these lecture notes, it is very convenient to introduce the annihilation operator \mathbf{a} and, its hermitian conjugate, the creation operator \mathbf{a}^\dagger :

$$\mathbf{a} = \frac{\mathbf{X} + i\mathbf{P}}{\sqrt{2}} \equiv \frac{1}{\sqrt{2}} \left(x + \frac{\partial}{\partial x} \right), \quad \mathbf{a}^\dagger = \frac{\mathbf{X} - i\mathbf{P}}{\sqrt{2}} \equiv \frac{1}{\sqrt{2}} \left(x - \frac{\partial}{\partial x} \right).$$

These operators are defined on $L^2(\mathbb{R}, \mathbb{C})$ with their domains given by $H^1(\mathbb{R}, \mathbb{C})$. We have the commutation relations

$$[\mathbf{X}, \mathbf{P}] = i\mathbf{I}, \quad [\mathbf{a}, \mathbf{a}^\dagger] = \mathbf{I}, \quad \mathbf{H} = \frac{\omega}{2}(\mathbf{P}^2 + \mathbf{X}^2) = \omega \left(\mathbf{a}^\dagger \mathbf{a} + \frac{1}{2} \mathbf{I} \right)$$

where $[\mathbf{A}, \mathbf{B}] = \mathbf{AB} - \mathbf{BA}$ and \mathbf{I} stands for the identity operator.

We apply the canonical commutation relation $[\mathbf{a}, \mathbf{a}^\dagger] = \mathbf{I}$, to obtain the spectral decomposition of $\mathbf{a}^\dagger \mathbf{a}$ (and therefore the Hamiltonian \mathbf{H}). Indeed, assuming $|\psi\rangle$ to be an eigenfunction of the operator $\mathbf{a}^\dagger \mathbf{a}$ associated to the eigenvalue λ , we have

$$\begin{aligned} \mathbf{a}^\dagger \mathbf{a}(\mathbf{a}|\psi\rangle) &= (\mathbf{a}\mathbf{a}^\dagger - \mathbf{I})\mathbf{a}|\psi\rangle = \mathbf{a}(\mathbf{a}^\dagger \mathbf{a} - \mathbf{I})|\psi\rangle = (\lambda - 1)(\mathbf{a}|\psi\rangle), \\ \mathbf{a}^\dagger \mathbf{a}(\mathbf{a}^\dagger|\psi\rangle) &= \mathbf{a}^\dagger(\mathbf{a}\mathbf{a}^\dagger)|\psi\rangle = \mathbf{a}^\dagger(\mathbf{a}^\dagger \mathbf{a} + \mathbf{I})|\psi\rangle = (\lambda + 1)(\mathbf{a}^\dagger|\psi\rangle). \end{aligned}$$

Therefore both $\mathbf{a}|\psi\rangle$ and $\mathbf{a}^\dagger|\psi\rangle$ should also be eigenfunctions of $\mathbf{a}^\dagger \mathbf{a}$ associated to eigenvalues $\lambda - 1$ and $\lambda + 1$. Note however that the operator $\mathbf{a}^\dagger \mathbf{a}$ is a positive semi-definite operator, and thus the only choice for λ is to be a non-negative integer. This means that spectrum of the

operator $\mathbf{a}^\dagger \mathbf{a}$ is given by the set of non-negative integers $\lambda_n = n$, $n = 0, 1, 2, \dots$. Furthermore, the associated eigenfunctions are given by

$$|\psi_n\rangle = \frac{\mathbf{a}^{\dagger n} |\psi_0\rangle}{\|\mathbf{a}^{\dagger n} |\psi_0\rangle\|_{L^2}} = \frac{1}{\sqrt{2^n n!}} \left(x - \frac{\partial}{\partial x}\right)^n \psi_0(x).$$

We can conclude by noting that $|\psi_0\rangle$ should satisfy $\mathbf{a}|\psi_0\rangle \equiv 0$, or equivalently $(x + \partial/\partial x)\psi_0(x) \equiv 0$. By solving this differential equation, we find

$$\psi_0(x) = \left(\frac{1}{\pi}\right)^{1/4} e^{-x^2/2}.$$

The eigenstates $|\psi_n\rangle$ are usually denoted by simpler notation of $|n\rangle$ (this is the notation that we will use through the rest of the lecture notes). These states are called Fock states or photon-number states (phonon-number states in the case of a mechanical oscillator) and form an eigenbasis for the wave-functions in $L^2(\mathbb{R}, \mathbb{C})$. Following the approach of operators, we will replace the Hilbert space $L^2(\mathbb{R}, \mathbb{C})$ by the equivalent one

$$\mathcal{H} = \left\{ \sum_{n \geq 0} c_n |n\rangle, (c_n)_{n \geq 0} \in l^2(\mathbb{C}) \right\}, \quad (1.1)$$

where $l^2(\mathbb{C})$ is the space of l^2 sequences with complex values. For $n > 0$, we have

$$\mathbf{a}|n\rangle = \sqrt{n} |n-1\rangle, \quad \mathbf{a}^\dagger |n\rangle = \sqrt{n+1} |n+1\rangle.$$

In these new notations, the domain of the operators \mathbf{a} and \mathbf{a}^\dagger is given by

$$\left\{ \sum_{n \geq 0} c_n |n\rangle, (c_n)_{n \geq 0} \in h^1(\mathbb{C}) \right\}, \quad h^1(\mathbb{C}) = \left\{ (c_n)_{n \geq 0} \in l^2(\mathbb{C}) \mid \sum_{n \geq 0} n |c_n|^2 < \infty \right\}.$$

The Hermitian operator $\mathbf{N} = \mathbf{a}^\dagger \mathbf{a}$, is called the photon-number operator, and is defined with its domain

$$\left\{ \sum_{n \geq 0} c_n |n\rangle, (c_n)_{n \geq 0} \in h^2(\mathbb{C}) \right\}, \quad h^2(\mathbb{C}) = \left\{ (c_n)_{n \geq 0} \in l^2(\mathbb{C}) \mid \sum_{n \geq 0} n^2 |c_n|^2 < \infty \right\}.$$

Finally, as proven above \mathbf{N} admits a discrete non-degenerate spectrum simply given by \mathbb{N} .

For any analytic function f we have the following commutation relations

$$\mathbf{a}f(\mathbf{N}) = f(\mathbf{N} + \mathbf{I})\mathbf{a}, \quad \mathbf{a}^\dagger f(\mathbf{N}) = f(\mathbf{N} - \mathbf{I})\mathbf{a}^\dagger.$$

In particular for any angle θ , $e^{i\theta \mathbf{N}} \mathbf{a} e^{-i\theta \mathbf{N}} = e^{-i\theta} \mathbf{a}$ and $e^{i\theta \mathbf{N}} \mathbf{a}^\dagger e^{-i\theta \mathbf{N}} = e^{i\theta} \mathbf{a}^\dagger$.

1.1.3 Glauber displacement operator and coherent states

For any amplitude $\alpha \in \mathbb{C}$, the Glauber displacement unitary operator \mathbf{D}_α is defined by

$$\mathbf{D}_\alpha = e^{\alpha \mathbf{a}^\dagger - \alpha^* \mathbf{a}}.$$

Indeed, the operator $\alpha \mathbf{a}^\dagger - \alpha^* \mathbf{a}$ being anti-Hermitian and densely defined on \mathcal{H} , it generates a strongly continuous group of isometries on \mathcal{H} . We have $\mathbf{D}_\alpha^{-1} = \mathbf{D}_\alpha^\dagger = \mathbf{D}_{-\alpha}$. The following Glauber formula is useful: if two operators \mathbf{A} and \mathbf{B} commute with their commutator, i.e., if $[\mathbf{A}, [\mathbf{A}, \mathbf{B}]] = [\mathbf{B}, [\mathbf{A}, \mathbf{B}]] = 0$, then we have $e^{\mathbf{A}+\mathbf{B}} = e^{\mathbf{A}} e^{\mathbf{B}} e^{-\frac{1}{2}[\mathbf{A}, \mathbf{B}]}$. Since $\mathbf{A} = \alpha \mathbf{a}^\dagger$ and $\mathbf{B} = -\alpha^* \mathbf{a}$ satisfy this assumption, we have another expression for \mathbf{D}_α

$$\mathbf{D}_\alpha = e^{-\frac{|\alpha|^2}{2}} e^{\alpha \mathbf{a}^\dagger} e^{-\alpha^* \mathbf{a}} = e^{+\frac{|\alpha|^2}{2}} e^{-\alpha^* \mathbf{a}} e^{\alpha \mathbf{a}^\dagger}.$$

We have also for any $\alpha, \beta \in \mathbb{C}$

$$\mathbf{D}_\alpha \mathbf{D}_\beta = e^{\frac{\alpha \beta^* - \alpha^* \beta}{2}} \mathbf{D}_{\alpha+\beta}$$

This results from Glauber formula with $\mathbf{A} = \alpha \mathbf{a}^\dagger - \alpha^* \mathbf{a}$, $\mathbf{B} = \beta \mathbf{a}^\dagger - \beta^* \mathbf{a}$ and $[\mathbf{A}, \mathbf{B}] = \alpha \beta^* - \alpha^* \beta$.

The terminology displacement has its origin in the following property:

$$\forall \alpha \in \mathbb{C}, \quad \mathbf{D}_{-\alpha} \mathbf{a} \mathbf{D}_\alpha = \mathbf{a} + \alpha \mathbf{I} \quad \text{and} \quad \mathbf{D}_{-\alpha} \mathbf{a}^\dagger \mathbf{D}_\alpha = \mathbf{a}^\dagger + \alpha^* \mathbf{I}.$$

This relation can be derived from Baker-Campbell-Hausdorff formula

$$e^{\mathbf{X}} \mathbf{Y} e^{-\mathbf{X}} = \mathbf{Y} + [\mathbf{X}, \mathbf{Y}] + \frac{1}{2!} [\mathbf{X}, [\mathbf{X}, \mathbf{Y}]] + \frac{1}{3!} [\mathbf{X}, [\mathbf{X}, [\mathbf{X}, \mathbf{Y}]]] + \dots$$

To the classical state (x, p) in the position-momentum phase space, is associated a quantum state usually called coherent state of complex amplitude $\alpha = (x + ip)/\sqrt{2}$ and denoted by $|\alpha\rangle$:

$$|\alpha\rangle = \mathbf{D}_\alpha |0\rangle = e^{-\frac{|\alpha|^2}{2}} \sum_{n=0}^{+\infty} \frac{\alpha^n}{\sqrt{n!}} |n\rangle. \quad (1.2)$$

$|\alpha\rangle$ corresponds to the translation of the Gaussian profile corresponding to the fundamental Fock state $|0\rangle$ also called the vacuum state:

$$|\alpha\rangle \equiv \left(\mathbb{R} \ni x \mapsto \frac{1}{\pi^{1/4}} e^{i\sqrt{2}x\Im\alpha} e^{-\frac{(x-\sqrt{2}\Re\alpha)^2}{2}} \right).$$

This usual notation is potentially ambiguous: the coherent state $|\alpha\rangle$ is very different from the photon-number state $|n\rangle$ where n is a non negative integer. The probability p_n to obtain $n \in \mathbb{N}$ during the measurement of \mathbf{N} with $|\alpha\rangle$ obeys to a Poisson law $p_n = e^{-|\alpha|^2} |\alpha|^{2n}/n!$. The resulting average energy is thus given by $\langle \alpha | \mathbf{N} | \alpha \rangle = |\alpha|^2$. Only for $\alpha = 0$ and $n = 0$, these quantum states coincide. For any $\alpha, \beta \in \mathbb{C}$, we have

$$\langle \alpha | \beta \rangle = \langle 0 | \mathbf{D}_{-\alpha} \mathbf{D}_\beta | 0 \rangle = e^{-\frac{|\beta-\alpha|^2}{2}} \langle 0 | \beta - \alpha \rangle = e^{-\frac{|\beta-\alpha|^2}{2}} e^{\frac{\alpha^* \beta - \alpha \beta^*}{2}}.$$

This results from $\mathbf{D}_{-\alpha} \mathbf{D}_\beta = e^{\frac{\alpha^* \beta - \alpha \beta^*}{2}} \mathbf{D}_{\beta-\alpha}$.

The coherent state $\alpha \in \mathbb{C}$ is an eigenstate of \mathbf{a} associated to the eigenvalue $\alpha \in \mathbb{C}$:

$$\mathbf{a} |\alpha\rangle = \alpha |\alpha\rangle.$$

Since $\mathbf{H} = \omega(\mathbf{N} + \frac{1}{2}\mathbf{I})$, the solution of the Schrödinger equation $\frac{d}{dt}|\psi\rangle = -i\mathbf{H}|\psi\rangle$, with initial value a coherent state $|\psi\rangle_{t=0} = |\alpha_0\rangle$ ($\alpha_0 \in \mathbb{C}$) remains a coherent state with time varying amplitude $\alpha_t = e^{-i\omega t}\alpha_0$:

$$|\psi\rangle_t = e^{-i\omega t/2}|\alpha_t\rangle.$$

These coherent solutions are the quantum counterpart of the classical solutions: $x_t = \sqrt{2}\Re(\alpha_t)$ and $p_t = \sqrt{2}\Im(\alpha_t)$ are solutions of the classical Hamilton equations $\frac{d}{dt}x = \omega p$ and $\frac{d}{dt}p = -\omega x$ since $\frac{d}{dt}\alpha_t = -i\omega\alpha_t$. The addition of a control input, a classical drive of complex amplitude $u \in \mathbb{C}$ (encoding the amplitude and phase of the drive), yields to the following controlled Schrödinger equation

$$\frac{d}{dt}|\psi\rangle = -i\left(\omega\left(\mathbf{a}^\dagger\mathbf{a} + \frac{1}{2}\right) + (u^*(t)\mathbf{a} + u(t)\mathbf{a}^\dagger)\right)|\psi\rangle$$

Such a classical control is achieved in the case of a mechanical oscillator by a direct manipulation of the particle (e.g. by applying an electric force to an ion trapped in a Coulomb potential) and in the case of an electrical one, by connecting the oscillator to a large current source whose quantum fluctuations could be neglected.

It is the quantum version of the controlled classical harmonic oscillator

$$\frac{d}{dt}x = \omega p + \Im(u(t)), \quad \frac{d}{dt}p = -\omega x - \Re(u(t)).$$

1.2 Qubit: spin-half models

1.2.1 Schrödinger equation and Pauli matrices

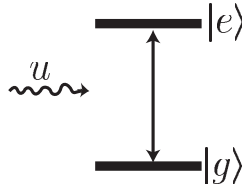

Figure 1.1: a 2-level system

Take the system of Figure 1.1. Typically, it corresponds to electronic states in the potential created by the nuclei of an atom. The system is either in the ground state $|g\rangle$ of energy E_g , or in the excited state $|e\rangle$ of energy E_e ($E_g < E_e$). We discard the other energy levels. This simplification to a few energy levels is similar to the case of flexible mechanical systems where one would consider only few vibrational modes: instead of writing the partial differential form of the Schrödinger equation describing the time evolution of the electronic wave function, we consider only its components along two eigenmodes, one corresponding to the fundamental state and the other to the first excited state. Later, we will see that controls are chosen close to resonance with the transition frequency between these two energy levels, and thus such a simplification is very natural: the higher energy levels do not get populated.

The quantum state, described by $|\psi\rangle \in \mathbb{C}^2$ of length 1, $\langle\psi|\psi\rangle = 1$, is a linear superposition of $|g\rangle \in \mathbb{C}^2$, the ground state, and $|e\rangle \in \mathbb{C}^2$, the excited state, two orthogonal states, $\langle g|e\rangle = 0$, of length 1, $\langle g|g\rangle = \langle e|e\rangle = 1$:

$$|\psi\rangle = \psi_g|g\rangle + \psi_e|e\rangle$$

with $\psi_g, \psi_e \in \mathbb{C}$ the complex probability amplitudes¹. This state $|\psi\rangle$ depends on time t . For this simple 2-level system, the Schrödinger equation is just an ordinary differential equation

$$i \frac{d}{dt} |\psi\rangle = \mathbf{H} |\psi\rangle = \left(E_g |g\rangle\langle g| + E_e |e\rangle\langle e| \right) |\psi\rangle \quad (1.3)$$

completely characterized by \mathbf{H} , the Hamiltonian operator ($\mathbf{H}^\dagger = \mathbf{H}$) corresponding to the system's energy².

Since energies are defined up to a scalar, the Hamiltonians \mathbf{H} and $\mathbf{H} + u_0(t)\mathbf{I}$ (with an arbitrary $u_0(t) \in \mathbb{R}$) describe the same physical system. If $|\psi\rangle$ obeys $i \frac{d}{dt} |\psi\rangle = \mathbf{H} |\psi\rangle$ then $|\chi\rangle = e^{-i\theta_0(t)} |\psi\rangle$ with $\frac{d}{dt} \theta_0 = u_0$ satisfies $i \frac{d}{dt} |\chi\rangle = (\mathbf{H} + u_0 \mathbf{I}) |\chi\rangle$ where $\mathbf{I} = |g\rangle\langle g| + |e\rangle\langle e|$ stands for the identity operator. Thus for all θ_0 , $|\psi\rangle$ and $e^{-i\theta_0} |\psi\rangle$ are attached to the same physical system. The global phase of the quantum state $|\psi\rangle$ can be arbitrarily chosen. It is as if we can add a control u_0 of the global phase, this control input u_0 being arbitrary (gauge degree of freedom relative to the origin of the energy scale). Thus the one parameter family of Hamiltonians

$$\left((E_g + u_0) |g\rangle\langle g| + (E_e + u_0) |e\rangle\langle e| \right)_{u_0 \in \mathbb{R}}$$

describes the same system. It is then natural to take $u_0 = -\frac{E_e - E_g}{2}$ and to set $\omega_{eg} = (E_e - E_g)$, the frequency of the photon emitted or absorbed as a consequence of the transition between the ground and excited states. This frequency is associated to the light emitted by the electron during the jump from $|e\rangle$ to $|g\rangle$. This light could be observed in a spectroscopy experiment: its frequency is a signature of the atom.

It is usual to consider the following operators on \mathbb{C}^2 , the Hilbert space of the qubit:

$$\begin{aligned} \sigma_- &= |g\rangle\langle e|, & \sigma_+ &= \sigma_-^\dagger = |e\rangle\langle g|, & \sigma_x &= \sigma_- + \sigma_+ = |g\rangle\langle e| + |e\rangle\langle g|, \\ \sigma_y &= i\sigma_- - i\sigma_+ = i|g\rangle\langle e| - i|e\rangle\langle g|, & \sigma_z &= \sigma_+ \sigma_- - \sigma_- \sigma_+ = |e\rangle\langle e| - |g\rangle\langle g|. \end{aligned} \quad (1.4)$$

σ_x , σ_y and σ_z are the Pauli operators. They satisfy $\sigma_x^2 = \sigma_y^2 = \sigma_z^2 = \mathbf{I}$, and anti-commute

$$\sigma_x \sigma_y = -\sigma_y \sigma_x = i\sigma_z, \quad \sigma_y \sigma_z = -\sigma_z \sigma_y = i\sigma_x, \quad \sigma_z \sigma_x = -\sigma_x \sigma_z = i\sigma_y$$

and thus $[\sigma_x, \sigma_y] = 2i\sigma_z$, $[\sigma_y, \sigma_z] = 2i\sigma_x$, $[\sigma_z, \sigma_x] = 2i\sigma_y$. The above uncontrolled evolution (1.3) is therefore governed by the Hamiltonian $\mathbf{H} = \omega_{eg} \sigma_z / 2$ and the solution of $\frac{d}{dt} |\psi\rangle = -i\mathbf{H} |\psi\rangle$ is given by

$$|\psi\rangle_t = e^{-i \left(\frac{\omega_{eg} t}{2} \right) \sigma_z} |\psi\rangle_0 = \cos \left(\frac{\omega_{eg} t}{2} \right) |\psi\rangle_0 - i \sin \left(\frac{\omega_{eg} t}{2} \right) \sigma_z |\psi\rangle_0$$

since for any angle θ we have

$$e^{i\theta \sigma_x} = \cos \theta \mathbf{I} + i \sin \theta \sigma_x, \quad e^{i\theta \sigma_y} = \cos \theta \mathbf{I} + i \sin \theta \sigma_y, \quad e^{i\theta \sigma_z} = \cos \theta \mathbf{I} + i \sin \theta \sigma_z.$$

¹In a more standard formulation, $|g\rangle$ stands for $\begin{pmatrix} 1 \\ 0 \end{pmatrix}$, $|e\rangle$ for $\begin{pmatrix} 0 \\ 1 \end{pmatrix}$ and $|\psi\rangle$ for $\begin{pmatrix} \psi_g \\ \psi_e \end{pmatrix}$.

²In a more standard formulation, $|g\rangle\langle g|$ stands for $\begin{pmatrix} 1 & 0 \\ 0 & 0 \end{pmatrix}$, $|e\rangle\langle e|$ for $\begin{pmatrix} 0 & 0 \\ 0 & 1 \end{pmatrix}$ and \mathbf{H} for $\begin{pmatrix} E_g & 0 \\ 0 & E_e \end{pmatrix}$.

Since the Pauli operators anti-commute, we have the useful relationships:

$$e^{i\theta\sigma_x}\sigma_y = \sigma_y e^{-i\theta\sigma_x}, \quad e^{i\theta\sigma_y}\sigma_z = \sigma_z e^{-i\theta\sigma_y}, \quad e^{i\theta\sigma_z}\sigma_x = \sigma_x e^{-i\theta\sigma_z}.$$

Assume now that the system is in interaction with a classical electromagnetic field (a large field whose quantum fluctuations are neglected) described by the control input $u(t) \in \mathbb{C}$ (encoding the amplitude and phase of a classical drive). Then the evolution of $|\psi\rangle$ is given by

$$i\frac{d}{dt}|\psi\rangle = \frac{1}{2}(\omega_{\text{eg}}\sigma_z + (u^*(t)\sigma_+ + \bar{u}(t)\sigma_-))|\psi\rangle = \frac{1}{2}(\omega_{\text{eg}}\sigma_z + \Re(u(t))\sigma_x + \Im(u(t))\sigma_y)|\psi\rangle. \quad (1.5)$$

Since σ_x , σ_y and σ_z do not commute, there is no simple expression for the solution of the associated Cauchy problem when u depends on t (in general the system is not integrable).

1.2.2 Bloch sphere representation

The orthogonal projector $\rho = |\psi\rangle\langle\psi|$, the density operator associated to the pure state $|\psi\rangle$, obeys to the Liouville equation $\frac{d}{dt}\rho = -i[\mathbf{H}, \rho]$. While a more thorough description of the density matrix formulation, together with its application to the modeling of open quantum systems, will be given later, here we apply this formulation to present the Bloch sphere representation of a single qubit system. Such a representation is a useful tool exploiting the smooth correspondence between ρ and the unit ball of \mathbb{R}^3 considered in Euclidian space:

$$\rho = \frac{\mathbf{I} + x\sigma_x + y\sigma_y + z\sigma_z}{2}, \quad (x, y, z) \in \mathbb{R}^3, \quad x^2 + y^2 + z^2 \leq 1.$$

$(x, y, z) \in \mathbb{R}^3$ are the coordinates in the orthonormal frame $(\vec{i}, \vec{j}, \vec{k})$ of the Bloch vector $\vec{M} \in \mathbb{R}^3$

$$\vec{M} = x\vec{i} + y\vec{j} + z\vec{k}.$$

In general, considering the case of an open quantum system undergoing dissipation, this vector lies on or inside the unit sphere, called Bloch sphere. However, here considering the case of a pure quantum state, where the density matrix is equivalent to a Rank 1 projector $\rho = |\psi\rangle\langle\psi|$, this vector lies on the unit sphere. In order to see this, we note that $\text{Tr}(\rho^2) = x^2 + y^2 + z^2$, and ρ being a projector $\text{Tr}(\rho^2) = \text{Tr}(\rho) = 1$. The translation of Liouville equation on \vec{M} yields with $\mathbf{H} = \omega_{\text{eg}}\sigma_z/2$: $\frac{d}{dt}\vec{M} = \omega_{\text{eg}}\vec{k} \times \vec{M}$. For the two-level system with the coherent drive described by the complex-value control u , $\mathbf{H} = \frac{\omega_{\text{eg}}}{2}\sigma_z + \frac{\Re(u)}{2}\sigma_x + \frac{\Im(u)}{2}\sigma_y$ and the Liouville equation reads, with the Bloch vector \vec{M} representation,

$$\frac{d}{dt}\vec{M} = (\Re(u)\vec{i} + \Im(u)\vec{j} + \omega_{\text{eg}}\vec{k}) \times \vec{M}.$$

1.3 Composite spin-spring systems

As discussed through the Appendix A, a composite quantum system is modeled on the state space given by the tensor product of the subsystems as opposed to the classical case, where this is given by the Cartesian product. In the particular case of the systems composed of a spin-half particle and a quantum harmonic oscillator, the state space is given by $\mathbb{C}^2 \otimes \mathcal{H}$,

where \mathcal{H} the Hilbert space of the quantum harmonic oscillator (1.1) is equivalent to $L^2(\mathbb{R}, \mathbb{C})$. This Hilbert space is given by

$$\mathbb{C}^2 \otimes \mathcal{H} = \left\{ \sum_{n \geq 0} (c_{g,n}|g, n\rangle + c_{e,n}|e, n\rangle) \mid (c_{g,n})_{n \geq 0}, (c_{e,n})_{n \geq 0} \in l^2(\mathbb{C}) \right\},$$

where $|g, n\rangle = |g\rangle \otimes |n\rangle$ (resp. $|e\rangle \otimes |n\rangle$) represent the case where the qubit is in the ground (resp. excited) state and the quantum harmonic oscillator in the state $|n\rangle$. While, throughout the lecture notes, we will follow such a representation consisting in the Hilbert basis decomposition of the quantum states, this is also equivalent to a representation in $\mathbb{C}^2 \otimes L^2(\mathbb{R}, \mathbb{C})$, where the quantum state $|\psi\rangle$ is given by two components $(\psi_g(t, x), \psi_e(t, x))$. In this representation, for each time t , the complex value functions ψ_g and ψ_e belong to $L^2(\mathbb{R}, \mathbb{C})$.

1.3.1 Jaynes-Cummings Hamiltonians and propagators

Through this subsection, we will study the coupling of a two-level atom to a quantum harmonic oscillator, modeling e.g. the electrical field confined in a cavity mode (see Figure 1.2). This is a typical building block of experiments within the context of Cavity Quantum Electrodynamics (CQED) [36].

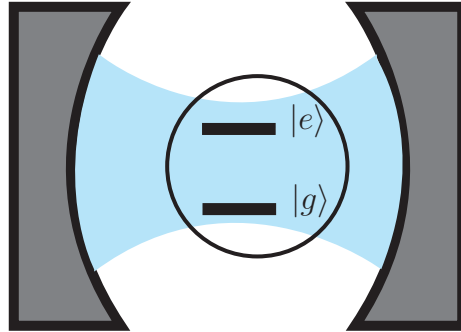

Figure 1.2: A composite spin-spring system: two-level atom coupled to quantized electromagnetic field confined in a cavity mode.

The Jaynes-Cummings Hamiltonians [37] provide the simplest modeling of such an interaction. We consider two possible coupling regimes, 1- the resonant regime where the qubit's transition frequency ω_{eg} is close enough to the quantum harmonic oscillator's frequency ω_c , such that the oscillator and the qubit exchange energy, 2- the dispersive regime, where such an energy exchange does not occur, but where the qubit's excitation shifts the resonance frequency of the quantum harmonic oscillator. Here, we recall the simplest forms of these Hamiltonians, and for a deeper and complete exposure we invite the readers to see [36].

Absence of coupling - The Hamiltonian is given by the addition of the Hamiltonians of a single qubit and a single quantum harmonic oscillator as presented in the previous sections

$$\mathbf{H} = \mathbf{H}_q + \mathbf{H}_c, \quad \mathbf{H} = \underbrace{\frac{\omega_{eg}}{2} \sigma_z \otimes \mathbf{I}_c}_{\mathbf{H}_q} + \underbrace{\omega_c \mathbf{I}_q \otimes (\mathbf{a}^\dagger \mathbf{a} + \frac{\mathbf{I}_c}{2})}_{\mathbf{H}_c}.$$

Here \mathbf{I}_q and \mathbf{I}_c stand respectively for the identity operator in the qubit and harmonic oscillator Hilbert spaces. Also ω_{eg} and ω_c represent the resonance frequencies of the qubit and the harmonic oscillator.

Resonant coupling - A coupling between these two systems can be modeled by the addition of the interaction Hamiltonian:

$$\mathbf{H}_{int} = i\frac{\Omega}{2}\boldsymbol{\sigma}_x \otimes (\mathbf{a}^\dagger - \mathbf{a}). \quad (1.6)$$

As will be seen in the next chapter, such an interaction gives rise to a resonant exchange of energy between the qubit and the harmonic oscillator as soon as the coupling strength Ω is significantly larger than the difference between the two transition frequencies: $\Omega \gg |\Delta| = |\omega_{eg} - \omega_c|$. The system's dynamics is given by the Schrödinger equation $i\frac{d}{dt}|\psi\rangle = \mathbf{H}_{res}|\psi\rangle$, where $\mathbf{H}_{res} = \mathbf{H}_q + \mathbf{H}_c + \mathbf{H}_{int}$. This is equivalent to the following coupled set of partial differential equations

$$\begin{aligned} i\frac{\partial\psi_g}{\partial t} &= -\frac{\omega_{eg}}{2}\psi_g + \frac{\omega_c}{2}\left(x^2 - \frac{\partial^2}{\partial x^2}\right)\psi_g - i\frac{\Omega}{\sqrt{2}}\frac{\partial}{\partial x}\psi_e \\ i\frac{\partial\psi_e}{\partial t} &= \frac{\omega_{eg}}{2}\psi_e + \frac{\omega_c}{2}\left(x^2 - \frac{\partial^2}{\partial x^2}\right)\psi_e - i\frac{\Omega}{\sqrt{2}}\frac{\partial}{\partial x}\psi_g \end{aligned}$$

with $\|\psi_g\|_{L^2(\mathbb{R},\mathbb{C})}^2 + \|\psi_e\|_{L^2(\mathbb{R},\mathbb{C})}^2 = 1$. However, as it will be seen through the next chapter, it is significantly easier to solve these dynamics in its previous form, using the creation and annihilation operators.

Dispersive coupling - In the case where the coupling strength $|\Omega|$ is smaller than the detuning $|\Delta = \omega_{eg} - \omega_c|$, the above model gives rise to another effective Hamiltonian:

$$\mathbf{H}_{disp} = \mathbf{H}_c + \mathbf{H}_q - \frac{\chi}{2}\boldsymbol{\sigma}_z \otimes \mathbf{N}. \quad (1.7)$$

We leave the curious reader to follow the derivation of this effective Hamiltonian through [36, Section 3.4.4]. Such an interaction Hamiltonian can be understood in the following way: In the absence of the interaction Hamiltonian, the resonance frequency of the qubit is given by ω_{eg} and that of the harmonic oscillator is given by ω_c ; In presence of such an interaction, the frequency of the harmonic oscillator is shifted to $\omega_c + \chi/2$ when the qubit is in the ground state and shifted to $\omega_c - \chi/2$ when the qubit is in the excited state; Similarly, the transition frequency of the qubit is shifted to $\omega_{eg} - n\chi$, when the harmonic oscillator is in the Fock state $|n\rangle$.

The Hamiltonian (1.7) is diagonal in the Hilbert basis given by the elements $|g, n\rangle$ and $|e, n\rangle$ and therefore, the solution to the Schrödinger equation $i\frac{d}{dt}|\psi\rangle = \mathbf{H}_{disp}|\psi\rangle$ can be calculated easily. Indeed, this solution is given by $|\psi\rangle_t = \mathbf{U}_{disp}(t)|\psi_0\rangle$, where the unitary operator

$$\mathbf{U}_{disp}(t) = e^{i\omega_{eg}t/2} \exp(-i(\omega_c + \chi/2)t\mathbf{N}) \otimes |g\rangle\langle g| + e^{-i\omega_{eg}t/2} \exp(-i(\omega_c - \chi/2)t\mathbf{N}) \otimes |e\rangle\langle e|, \quad (1.8)$$

where $\exp(i\theta\mathbf{N}) = \sum_{n \geq 0} e^{in\theta}|n\rangle\langle n|$ is a bounded operator on the Hilbert space \mathcal{H} of the harmonic oscillator. The above Schrödinger equation is also equivalent to the following set of

uncoupled partial differential equations

$$\begin{aligned} i\frac{\partial\psi_g}{\partial t} &= -\frac{1}{2}(\omega_{\text{eg}} + \frac{\chi}{2})\psi_g + \frac{1}{2}(\omega_c + \frac{\chi}{2})(x^2 - \frac{\partial^2}{\partial x^2})\psi_g \\ i\frac{\partial\psi_e}{\partial t} &= +\frac{1}{2}(\omega_{\text{eg}} + \frac{\chi}{2})\psi_e + \frac{1}{2}(\omega_c - \frac{\chi}{2})(x^2 - \frac{\partial^2}{\partial x^2})\psi_e \end{aligned}$$

Finally, we note that, in the case that the quantum harmonic oscillator and/or the qubit are driven by classical fields, one needs to add to the above Hamiltonian, the controlled terms $(u_c^*(t)\mathbf{a} + u_c(t)\mathbf{a}^\dagger)$ and/or $(u_q^*(t)\boldsymbol{\sigma}_- + u_q(t)\boldsymbol{\sigma}_+)$. Notice that $\boldsymbol{\sigma}_+ = (\boldsymbol{\sigma}_-)^\dagger$ and thus the lowering qubit operator $\boldsymbol{\sigma}_-$ plays the role of \mathbf{a} . Here $u_c, u_q \in \mathbb{C}$ are local control inputs, u_c attached to the oscillator and u_q to the qubit.

1.3.2 Laser manipulation of a trapped ion

Through this subsection, we consider another composite system comprising a qubit and a quantum harmonic oscillator. This corresponds to the laser manipulation of an ion that is trapped in a Coulomb potential. The laser field could be considered as a large classical field, where the quantum fluctuations are neglected, and therefore its coupling to the qubit could be modeled in a similar manner to (1.5). However, in the present system the qubit (trapped ion) undergoes vibrations and this oscillatory motion is quantized as a quantum harmonic oscillator. The complex parameter $u(t)$ in (1.5) depends on the position of this mechanical oscillator, leading to the following Hamiltonian

$$\mathbf{H} = \omega_m \mathbf{I}_q \otimes (\mathbf{a}^\dagger \mathbf{a} + \frac{\mathbf{I}_m}{2}) + \frac{\omega_{\text{eg}}}{2} \boldsymbol{\sigma}_z \otimes \mathbf{I}_m + (u^*(t)\boldsymbol{\sigma}_+ \otimes e^{i\eta(\mathbf{a}+\mathbf{a}^\dagger)} + u(t)\boldsymbol{\sigma}_- \otimes e^{-i\eta(\mathbf{a}+\mathbf{a}^\dagger)}).$$

In this Hamiltonian, \mathbf{I}_q and \mathbf{I}_m stand for the identity operator on the Hilbert space of the qubit and of the mechanical oscillator. Also, ω_m and ω_{eg} stand for the vibration frequency of the ion and the transition frequency of the qubit. Finally, in the last term, the operator $e^{i\eta(\mathbf{a}+\mathbf{a}^\dagger)}$ (a bounded operator on the Hilbert space of the mechanical oscillator, see Subsection 1.1.3) models the dependence of the coupling on the position of the ion (here a quantum observable $\mathbf{X} = (\mathbf{a} + \mathbf{a}^\dagger)/\sqrt{2}$). Here $\eta = \eta_0 \cos(\theta)$, where θ denotes the angle between the propagation axis of the laser field and the oscillation direction of the trapped ion, and η_0 denotes the Lamb-Dicke parameter which is generally smaller than 1.

Finally, the Schrödinger equation $i\frac{d}{dt}|\psi\rangle = \mathbf{H}|\psi\rangle$ is equivalent to the following set of coupled partial differential equations:

$$\begin{aligned} i\frac{\partial\psi_g}{\partial t} &= -\frac{\omega_{\text{eg}}}{2}\psi_g + \frac{\omega_m}{2}(x^2 - \frac{\partial^2}{\partial x^2})\psi_g + u(t)e^{-i\eta\sqrt{2}x}\psi_e \\ i\frac{\partial\psi_e}{\partial t} &= +\frac{\omega_{\text{eg}}}{2}\psi_e + \frac{\omega_m}{2}(x^2 - \frac{\partial^2}{\partial x^2})\psi_e + u^*(t)e^{i\eta\sqrt{2}x}\psi_g. \end{aligned}$$

Simplification of notations

Through the rest of these lecture notes, and in order to lighten the mathematical formulas, we follow a generally accepted approach. Whenever no confusion is created, we remove the tensor products in the operators defined on composite systems. For instance the Hamiltonian \mathbf{H}_{res} of the Subsection 1.3.1

$$\mathbf{H}_{res} = \frac{\omega_{\text{eg}}}{2}\boldsymbol{\sigma}_z \otimes \mathbf{I}_c + \omega_c \mathbf{I}_q \otimes (\mathbf{a}^\dagger \mathbf{a} + \frac{\mathbf{I}_c}{2}) + i\frac{\Omega}{2}\boldsymbol{\sigma}_x \otimes (\mathbf{a}^\dagger - \mathbf{a})$$

is replaced by

$$\mathbf{H}_{res} = \frac{\omega_{eg}}{2} \boldsymbol{\sigma}_z + \omega_c (\mathbf{a}^\dagger \mathbf{a} + \frac{\mathbf{I}}{2}) + i \frac{\Omega}{2} \boldsymbol{\sigma}_x (\mathbf{a}^\dagger - \mathbf{a}),$$

where $\mathbf{I} = \mathbf{I}_q \otimes \mathbf{I}_c$.

Chapter 2

Open-loop control of spins and springs

This chapter investigates the following question: for $|\psi\rangle$ obeying a controlled Schrödinger equation $i\frac{d}{dt}|\psi\rangle = (H_0 + \sum_{k=1}^m u_k H_k)|\psi\rangle$ with a given initial condition, find an open-loop control $[0, T] \ni t \mapsto u(t)$ such that at the final time T , $|\psi\rangle$ has reached a pre-specified target state. In different sections of this chapter, emphasis is put on different methods to construct efficient open-loop steering controls from one state to another one: resonant control and the rotation wave approximation are treated in section 2.1; quasi-static controls exploiting adiabatic invariance are presented in section 2.2; optimal control techniques minimizing $\int u^2$ are investigated in section 2.3. All these control techniques are routinely used in experiments that could be modeled as spins, springs or composite spin-spring systems. Therefore, while we provide a general framework for these techniques, we will emphasize on their application to spin-spring systems.

We consider a quantum system on the Hilbert space \mathcal{H} given by its wave function $|\psi\rangle$ on the unit sphere of \mathcal{H} and satisfying the following controlled Schrödinger equation

$$i\frac{d}{dt}|\psi\rangle = \left(\mathbf{H}_0 + \sum_{k=1}^m u_k \mathbf{H}_k \right) |\psi\rangle \quad (2.1)$$

where $u = (u_1, \dots, u_m) \in \mathbb{R}^m$ is formed by m independent controls and $\mathbf{H}_0, \mathbf{H}_1, \dots, \mathbf{H}_m$ are $m+1$ Hermitian operators on \mathcal{H} . Note once again that $|\psi\rangle$ and $e^{i\theta}|\psi\rangle$ for any phase $\theta \in [0, 2\pi[$ represent the same physical state. Therefore, the relevant control problem consists of, finding for a given initial and final state, $|\psi_i\rangle$ and $|\psi_f\rangle$, a set of piecewise continuous controls $[0, T] \ni t \mapsto u_k(t)$ such that the solution for $|\psi\rangle_0 = |\psi_i\rangle$ satisfies $|\psi\rangle_T = e^{i\theta}|\psi_f\rangle$.

2.1 Resonant control, rotating wave approximation

2.1.1 Multi-frequency averaging

Let us consider the system (2.1), defined on a finite-dimensional Hilbert space \mathcal{H} (while we will consider infinite dimensional examples later through this chapter, we will present the general framework only for the finite-dimensional case). For simplicity sakes, we also consider a single control, $m = 1$. We define the skew-Hermitian matrices $\mathbf{A}_k = -i\mathbf{H}_k$, $k = 0, 1$.

Assume that the single scalar control is of small amplitude and admits an almost periodic time-dependence

$$u(t) = \epsilon \left(\sum_{j=1}^r u_j e^{i\omega_j t} + u_j^* e^{-i\omega_j t} \right) \quad (2.2)$$

where $\epsilon > 0$ is a small parameter, ϵu_j is the constant complex amplitude associated to the frequency $\omega_j \geq 0$ and r stands for the number of independent frequencies ($\omega_j \neq \omega_k$ for $j \neq k$). We are interested in approximations, for ϵ tending to 0^+ , of trajectories $t \mapsto |\psi_\epsilon\rangle_t$ of (2.1). Such approximations should be explicit and valid on time intervals of length $O(\frac{1}{\epsilon})$ (first order approximation) or $O(\frac{1}{\epsilon^2})$ (second order approximation). The wave function $|\psi_\epsilon\rangle$ obeys the following linear time-varying differential equation

$$\frac{d}{dt} |\psi_\epsilon\rangle = \left(\mathbf{A}_0 + \epsilon \left(\sum_{j=1}^r u_j e^{i\omega_j t} + u_j^* e^{-i\omega_j t} \right) \mathbf{A}_1 \right) |\psi_\epsilon\rangle. \quad (2.3)$$

Consider the following change of variables

$$|\psi_\epsilon\rangle_t = e^{\mathbf{A}_0 t} |\phi_\epsilon\rangle_t \quad (2.4)$$

where $|\psi_\epsilon\rangle$ is replaced by $|\phi_\epsilon\rangle$. Through this change of variables, we put the system in the so-called ‘‘interaction frame’’:

$$\frac{d}{dt} |\phi_\epsilon\rangle = \epsilon \mathbf{B}(t) |\phi_\epsilon\rangle \quad (2.5)$$

where $\mathbf{B}(t)$ is a skew-Hermitian operator whose time-dependence is almost periodic¹:

$$\mathbf{B}(t) = \sum_{j=1}^r u_j e^{i\omega_j t} e^{-\mathbf{A}_0 t} \mathbf{A}_1 e^{\mathbf{A}_0 t} + u_j^* e^{-i\omega_j t} e^{-\mathbf{A}_0 t} \mathbf{A}_1 e^{\mathbf{A}_0 t}.$$

More precisely each entry of \mathbf{B} is a linear combination of oscillating terms of the form $e^{i\omega' t}$ with $\omega' \geq 0$. This results from the spectral decomposition of \mathbf{A}_0 to compute $e^{\mathbf{A}_0 t}$. Thus one can always decompose $\mathbf{B}(t)$ into a constant skew-Hermitian operator $\bar{\mathbf{B}}$ and the time derivative of a bounded and almost periodic skew-Hermitian operator $\tilde{\mathbf{B}}(t)$ whose entries are linear combinations of $e^{i\omega' t}$ with $\omega' > 0$:

$$\mathbf{B}(t) = \bar{\mathbf{B}} + \frac{d}{dt} \tilde{\mathbf{B}}(t). \quad (2.6)$$

Notice that we can always set $\tilde{\mathbf{B}}(t) = \frac{d}{dt} \tilde{\mathbf{C}}(t)$ where $\tilde{\mathbf{C}}$ is also an almost periodic skew-Hermitian operator. Then (2.5) reads $\frac{d}{dt} |\phi_\epsilon\rangle = \left(\epsilon \bar{\mathbf{B}} + \epsilon \frac{d}{dt} \tilde{\mathbf{B}} \right) |\phi_\epsilon\rangle$ and suggests the following almost periodic change of variables

$$|\chi_\epsilon\rangle = (\mathbf{I} - \epsilon \tilde{\mathbf{B}}(t)) |\phi_\epsilon\rangle \quad (2.7)$$

well defined for ϵ small enough and then close to identity. In the $|\chi_\epsilon\rangle$ frame, the dynamics reads

$$\frac{d}{dt} |\chi_\epsilon\rangle = \epsilon \left(\bar{\mathbf{B}} - \epsilon \tilde{\mathbf{B}} \bar{\mathbf{B}} - \epsilon \tilde{\mathbf{B}} \frac{d}{dt} \tilde{\mathbf{B}} \right) (\mathbf{I} - \epsilon \tilde{\mathbf{B}})^{-1} |\chi_\epsilon\rangle.$$

¹An almost periodic time function f is equal by definition to $F(\varpi_1 t, \dots, \varpi_p t)$ where the function F is a 2π -periodic function of each of its p arguments and the ϖ_j 's form a set of p different frequencies.

Since $\tilde{\mathbf{B}}(t)$ is almost periodic and $(\mathbf{I} - \epsilon\tilde{\mathbf{B}})^{-1} = \mathbf{I} + \epsilon\tilde{\mathbf{B}} + O(\epsilon^2)$, the dynamics of $|\chi_\epsilon\rangle$ reads

$$\frac{d}{dt}|\chi_\epsilon\rangle = \left(\epsilon\bar{\mathbf{B}} + \epsilon^2[\bar{\mathbf{B}}, \tilde{\mathbf{B}}(t)] - \epsilon^2\tilde{\mathbf{B}}(t)\frac{d}{dt}\tilde{\mathbf{B}}(t) + \epsilon^3\mathbf{E}(\epsilon, t) \right) |\chi_\epsilon\rangle$$

where the operator $\mathbf{E}(\epsilon, t)$ is still almost periodic versus t but now its entries are no more linear combinations of time exponentials. The operator $\tilde{\mathbf{B}}(t)\frac{d}{dt}\tilde{\mathbf{B}}(t)$ is an almost periodic operator whose entries are linear combinations of oscillating time exponentials. Thus we have

$$\tilde{\mathbf{B}}(t)\frac{d}{dt}\tilde{\mathbf{B}}(t) = \bar{\mathbf{D}} + \frac{d}{dt}\tilde{\mathbf{D}}(t)$$

where $\tilde{\mathbf{D}}(t)$ is almost periodic. With these notations we have

$$\frac{d}{dt}|\chi_\epsilon\rangle = \left(\epsilon\bar{\mathbf{B}} - \epsilon^2\bar{\mathbf{D}} + \epsilon^2\frac{d}{dt}\left([\bar{\mathbf{B}}, \tilde{\mathbf{C}}(t)] - \tilde{\mathbf{D}}(t)\right) + \epsilon^3\mathbf{E}(\epsilon, t) \right) |\chi_\epsilon\rangle \quad (2.8)$$

where the skew-Hermitian operators $\bar{\mathbf{B}}$ and $\bar{\mathbf{D}}$ are constant and the other ones $\tilde{\mathbf{C}}$, $\tilde{\mathbf{D}}$, and \mathbf{E} are almost periodic.

Similarly, the change of variable $|\xi_\epsilon\rangle = \left(\mathbf{I} - \epsilon^2\left([\bar{\mathbf{B}}, \tilde{\mathbf{C}}(t)] - \tilde{\mathbf{D}}(t)\right)\right)|\chi_\epsilon\rangle$ yields to

$$\frac{d}{dt}|\xi_\epsilon\rangle = \left(\epsilon\bar{\mathbf{B}} - \epsilon^2\bar{\mathbf{D}} + \epsilon^3\mathbf{F}(\epsilon, t)\right)|\xi_\epsilon\rangle \quad (2.9)$$

where $\mathbf{F}(\epsilon, t)$ is a bounded operator uniformly bounded versus t .

The pseudo-periodic mapping $\mathbf{J}(\epsilon, t)$ close to identity

$$|\phi_\epsilon\rangle \mapsto |\chi_\epsilon\rangle = \mathbf{J}(\epsilon, t)|\phi_\epsilon\rangle \triangleq \left(\mathbf{I} - \epsilon^2\left([\bar{\mathbf{B}}, \tilde{\mathbf{C}}(t)] - \tilde{\mathbf{D}}(t)\right)\right)\left(\mathbf{I} - \epsilon\tilde{\mathbf{B}}(t)\right)|\phi_\epsilon\rangle \quad (2.10)$$

exchanges the solution of (2.5) and of (2.9).

The first order approximation of $|\phi_\epsilon\rangle$ is given by the solution $|\phi_\epsilon^{1\text{st}}\rangle$ of

$$\frac{d}{dt}|\phi_\epsilon^{1\text{st}}\rangle = \epsilon\bar{\mathbf{B}}|\phi_\epsilon^{1\text{st}}\rangle \quad (2.11)$$

where $\bar{\mathbf{B}}$ can be interpreted as the averaged value of $\mathbf{B}(t)$:

$$\bar{\mathbf{B}} = \lim_{T \rightarrow \infty} \frac{1}{T} \int_0^T \mathbf{B}(t) dt = \lim_{T \rightarrow \infty} \frac{1}{T} \int_0^T \left(\sum_{j=1}^r u_j e^{i\omega_j t} e^{-\mathbf{A}_0 t} \mathbf{A}_1 e^{\mathbf{A}_0 t} + u_j^* e^{-i\omega_j t} e^{-\mathbf{A}_0 t} \mathbf{A}_1 e^{\mathbf{A}_0 t} \right) dt.$$

Approximating $\mathbf{B}(t)$ by $\bar{\mathbf{B}}$ in (2.5) is called the Rotating Wave Approximation (RWA). The second order approximation reads then

$$\frac{d}{dt}|\phi_\epsilon^{2\text{nd}}\rangle = (\epsilon\bar{\mathbf{B}} - \epsilon^2\bar{\mathbf{D}})|\phi_\epsilon^{2\text{nd}}\rangle. \quad (2.12)$$

In (2.11) and (2.12), the operators $\epsilon\bar{\mathbf{B}}$ and $\epsilon\bar{\mathbf{B}} - \epsilon^2\bar{\mathbf{D}}$ are skew-Hermitian: these approximate dynamics remain of Schrödinger type and are thus characterized by the approximate Hamiltonians

$$\bar{H}^{1\text{st}} = i\epsilon\bar{\mathbf{B}} \quad \text{and} \quad \bar{H}^{2\text{nd}} = i(\epsilon\bar{\mathbf{B}} - \epsilon^2\bar{\mathbf{D}}).$$

2.1.2 Approximation recipes

Such first order and second order approximations extend without any difficulties to the case of m scalar oscillating controls in (2.1). They can be summarized as follows (without introducing the small parameter ϵ and the skew-Hermitian operators \mathbf{A}_k). Consider the controlled Hamiltonian associated to $|\psi\rangle$

$$\mathbf{H} = \mathbf{H}_0 + \sum_{k=1}^m u_k \mathbf{H}_k \quad (2.13)$$

with m oscillating real controls

$$u_k(t) = \sum_{j=1}^r u_{k,j} e^{\omega_j t} + u_{k,j}^* e^{-\omega_j t}$$

where $u_{k,j}$ is the slowly varying complex amplitude associated to control number k and frequency ω_j . In the sequel, all the computations are done assuming $u_{k,j}$ constant. Nevertheless, the obtained approximate Hamiltonians given in (2.15) are also valid for slowly time-varying amplitudes.²

The interaction Hamiltonian

$$\mathbf{H}_{\text{int}}(t) = \sum_{k,j} (u_{k,j} e^{\omega_j t} + u_{k,j}^* e^{-\omega_j t}) e^{i\mathbf{H}_0 t} \mathbf{H}_k e^{-i\mathbf{H}_0 t} \quad (2.14)$$

is associated to the interaction frame via the unitary transformation $|\phi\rangle = e^{i\mathbf{H}_0 t} |\psi\rangle$. It admits the decomposition

$$\mathbf{H}_{\text{int}}(t) = \mathbf{H}_{\text{rwa}}^{1\text{st}} + \frac{d}{dt} \mathbf{I}_{\text{osc}}(t)$$

where $\mathbf{H}_{\text{rwa}}^{1\text{st}}$ is the averaged Hamiltonian corresponding to the non-oscillating part of \mathbf{H}_{int} (secular part) and \mathbf{I}_{osc} is the time integral of the oscillating part. \mathbf{I}_{osc} is an almost periodic Hermitian operator whose entries are linear combinations of oscillating time-exponentials. The Rotating Wave Approximation consists in approximating the time-varying Hamiltonian $\mathbf{H}_{\text{int}}(t)$ by $\mathbf{H}_{\text{rwa}}^{1\text{st}}$. This approximation is valid when the amplitudes $u_{k,j}$ are small. It is of first order. The second order approximation is then obtained by adding to $\mathbf{H}_{\text{rwa}}^{1\text{st}}$ a second order correction made by the averaged part \mathbf{J}_{rwa} of the almost periodic Hamiltonian

$$i \left(\frac{d}{dt} \mathbf{I}_{\text{osc}}(t) \right) \mathbf{I}_{\text{osc}}(t) = \mathbf{J}_{\text{rwa}} + \frac{d}{dt} \mathbf{J}_{\text{osc}}(t)$$

with \mathbf{J}_{osc} almost periodic. Notice \mathbf{J}_{rwa} is also Hermitian since $\frac{d}{dt} \mathbf{I}_{\text{osc}}^2 = \frac{d}{dt} \mathbf{I}_{\text{osc}} \mathbf{I}_{\text{osc}} + \mathbf{I}_{\text{osc}} \frac{d}{dt} \mathbf{I}_{\text{osc}}$. We can summarize these approximations as the following recipes:

$$\mathbf{H}_{\text{rwa}}^{1\text{st}} = \overline{\mathbf{H}_{\text{int}}}, \quad \mathbf{H}_{\text{rwa}}^{2\text{nd}} = \mathbf{H}_{\text{rwa}}^{1\text{st}} - i \overline{(\mathbf{H}_{\text{int}} - \overline{\mathbf{H}_{\text{int}}})} \left(\int_t (\mathbf{H}_{\text{int}} - \overline{\mathbf{H}_{\text{int}}}) \right) \quad (2.15)$$

where the over-line means taking the average.

²More precisely and according to exercise 1, we can assume that each $u_{k,j}$ is of small magnitude, admits a finite number of discontinuities and, between two successive discontinuities, is a slowly time varying function that is continuously differentiable.

2.1.3 Approximation lemma

A precise justification of the rotating wave approximation is given by the following lemma.

Lemma 1 (First and second order approximations). *Consider the solution $|\phi_\epsilon\rangle_t$ of (2.5) with initial condition $|\phi_\epsilon\rangle_0 = |\phi_a\rangle$. Denote by $|\phi_\epsilon^{1st}\rangle_t$ and $|\phi_\epsilon^{2nd}\rangle_t$ the solution of (2.11) and (2.12) respectively with the same initial condition, $|\phi_\epsilon^{1st}\rangle_0 = |\phi_\epsilon^{2nd}\rangle_0 = |\phi_a\rangle$. Then, there exist $M > 0$ and $\eta > 0$ such that for all $\epsilon \in]0, \eta[$ we have*

$$\max_{t \in [0, \frac{1}{\epsilon}]} \left\| |\phi_\epsilon\rangle_t - |\phi_\epsilon^{1st}\rangle_t \right\| \leq M\epsilon \quad \text{and} \quad \max_{t \in [0, \frac{1}{\epsilon^2}]} \left\| |\phi_\epsilon\rangle_t - |\phi_\epsilon^{2nd}\rangle_t \right\| \leq M\epsilon$$

Proof. We detail here only the proof for the second-order approximation. It is based on the mapping $\mathbf{J}(\epsilon, t)$ defined by (2.10). The proof for the first order approximation is similar and relies on the mapping defined by (2.7).

$|\xi_\epsilon\rangle_t = \mathbf{J}(\epsilon, t)|\phi_\epsilon\rangle_t$ is the solution of (2.9) starting from $\mathbf{J}(\epsilon, 0)|\phi_a\rangle$. According to (2.10), there exist $M_1 > 0$ and $\eta_1 > 0$, such that for all $\epsilon \in]0, \eta_1[$ and $t > 0$ we have $\| |\xi_\epsilon\rangle_t - |\phi_\epsilon\rangle_t \| \leq M_1\epsilon$. Thus, it is enough to show that exist η_2 and $M_2 > 0$ such that for all $\epsilon \in [0, \eta_2]$ we have

$$\max_{t \in [0, \frac{1}{\epsilon^2}]} \left\| |\xi_\epsilon\rangle_t - |\phi_\epsilon^{2nd}\rangle_t \right\| \leq M_2\epsilon.$$

Consider the following identity

$$|\xi_\epsilon\rangle_t = e^{t(\epsilon\bar{\mathbf{B}} - \epsilon^2\bar{\mathbf{D}})}|\xi\rangle_0 + \epsilon^3 \int_0^t e^{(t-\tau)(\epsilon\bar{\mathbf{B}} - \epsilon^2\bar{\mathbf{D}})} \mathbf{F}(\epsilon, \tau)|\xi_\epsilon\rangle_\tau d\tau \quad (2.16)$$

where $e^{t(\epsilon\bar{\mathbf{B}} - \epsilon^2\bar{\mathbf{D}})}$ is unitary for all t and $\mathbf{F}(\epsilon, \tau)$ is uniformly bounded versus $\epsilon > 0$ small and $t > 0$. This means that exist $M_0, \eta_0 > 0$ such that for all $t > 0$ and $\epsilon \in [0, \eta_0]$

$$\left\| |\xi_\epsilon\rangle_t - |\phi_\epsilon^{2nd}\rangle_t \right\| \leq \left\| (\mathbf{J}(\epsilon, 0) - \mathbf{I})|\phi_a\rangle \right\| + t\epsilon^3 M_0 \max_{\tau \in [0, t]} \left\| |\xi_\epsilon\rangle_\tau \right\|$$

since $|\phi_\epsilon^{2nd}\rangle_t = e^{t(\epsilon\bar{\mathbf{B}} - \epsilon^2\bar{\mathbf{D}})}|\phi_a\rangle$. Thus

$$\begin{aligned} \max_{\tau \in [0, t]} \left\| |\xi_\epsilon\rangle_\tau - |\phi_\epsilon^{2nd}\rangle_\tau \right\| &\leq \left\| (\mathbf{J}(\epsilon, 0) - \mathbf{I})|\phi_a\rangle \right\| + t\epsilon^3 M_0 \max_{\tau \in [0, t]} \left\| |\xi_\epsilon\rangle_\tau \right\| \\ &\leq M_1\epsilon + t\epsilon^3 M_0 \max_{\tau \in [0, t]} \left\| |\xi_\epsilon\rangle_\tau - |\phi_\epsilon^{2nd}\rangle_\tau \right\| + t\epsilon^3 M_0 \end{aligned}$$

since $(\mathbf{J}(\epsilon, 0) - \mathbf{I})|\phi_a\rangle = |\xi_\epsilon\rangle_0 - |\phi_a\rangle$ and $\| |\phi_\epsilon^{2nd}\rangle_\tau \| = \| |\phi_a\rangle \| = 1$. Consequently

$$\max_{\tau \in [0, t]} \left\| |\xi_\epsilon\rangle_\tau - |\phi_\epsilon^{2nd}\rangle_\tau \right\| \leq \frac{M_1\epsilon + t\epsilon^3 M_0}{1 - t\epsilon^3 M_0}.$$

With $\eta_2 = \min(\eta, 1/(2M_0))$ and $M_2 = 2(M_1 + M_0)$ we have, for all $\eta \in [0, \eta_2]$,

$$\max_{t \in [0, \frac{1}{\epsilon^2}]} \left\| |\xi_\epsilon\rangle_t - |\phi_\epsilon^{2nd}\rangle_t \right\| \leq M_2\epsilon.$$

□

Exercise 1. *The goal is to prove that, even if the amplitudes u_j are slowly varying, i.e., $u_j = u_j(\epsilon t)$ where $\tau \mapsto u_j(\tau)$ is continuously differentiable, the first and second order approximations remain valid. We have then two time-dependancies for*

$$\mathbf{B}(t, \tau) = \sum_{j=1}^r u_j(\tau) e^{i\omega_j t} e^{-\mathbf{A}_0 t} \mathbf{A}_1 e^{\mathbf{A}_0 t} + u_j^*(\tau) e^{-i\omega_j t} e^{-\mathbf{A}_0 t} \mathbf{A}_1 e^{\mathbf{A}_0 t}$$

with $\tau = \epsilon t$. Then $\frac{d}{dt} \mathbf{B} = \frac{\partial \mathbf{B}}{\partial t} + \epsilon \frac{\partial \mathbf{B}}{\partial \tau}$.

1. Extend the decomposition (2.6) to

$$\mathbf{B}(t, \tau) = \bar{\mathbf{B}}(\tau) + \frac{\partial \tilde{\mathbf{B}}}{\partial t}(t, \tau)$$

where $\tilde{\mathbf{B}}(t, \tau)$ is t -almost periodic with zero mean in t (τ is fixed here).

2. Show that the approximation Lemma 1 is still valid where (2.11) is replaced by

$$\frac{d}{dt} |\phi_\epsilon^{1st}\rangle = \epsilon \bar{\mathbf{B}}(\epsilon t) |\phi_\epsilon^{1st}\rangle$$

3. Show that the approximation Lemma 1 is still valid where (2.12) is replaced by

$$\frac{d}{dt} |\phi_\epsilon^{2nd}\rangle = (\epsilon \bar{\mathbf{B}}(\epsilon t) - \epsilon^2 \bar{\mathbf{D}}(\epsilon t)) |\phi_\epsilon^{2nd}\rangle$$

and where $\tilde{\mathbf{B}}(t, \tau) \frac{\partial \tilde{\mathbf{B}}}{\partial t}(t, \tau) = \bar{\mathbf{D}}(\tau) + \frac{\partial \tilde{\mathbf{D}}}{\partial t}(t, \tau)$ with $\tilde{\mathbf{D}}(t, \tau)$ almost periodic versus t and with zero t -mean.

4. Extend the above approximation lemma when $\tau \mapsto u_j(\tau)$ is piecewise continuous and, on each interval where it remains continuous, it is also continuously differentiable ($\tau \mapsto u_j(\tau)$ is made by the concatenation of continuously differentiable functions).

2.1.4 Qubits and Rabi oscillations

Let us consider the spin-half system described by (1.5) and fix the phase of the drive, so that the controlled dynamics is given by:

$$i \frac{d}{dt} |\psi\rangle = \left(\frac{\omega_{\text{eg}}}{2} \sigma_z + \frac{u(t)}{2} \sigma_x \right) |\psi\rangle.$$

Furthermore, we assume that $u(t) = v e^{i\omega_r t} + v^* e^{-i\omega_r t}$ where the complex amplitude v is chosen such that $|v| \ll \omega_{\text{eg}}$ and the frequency ω_r is close to ω_{eg} , i.e., $|\omega_{\text{eg}} - \omega_r| \ll \omega_{\text{eg}}$. Denote by $\Delta_r = \omega_{\text{eg}} - \omega_r$ the detuning between the control and the system then we get the standard form (2.13) with $m = 2$, $\mathbf{H}_0 = \frac{\omega_r}{2} \sigma_z$, $u_1 \mathbf{H}_1 = \frac{\Delta_r}{2} \sigma_z$ and $u_2 \mathbf{H}_2 = \frac{v e^{i\omega_r t} + v^* e^{-i\omega_r t}}{2} \sigma_x$ with $\|\mathbf{H}_0\|$ much larger than $\|u_1 \mathbf{H}_1 + u_2 \mathbf{H}_2\|$. A direct computation yields to the following interaction Hamiltonian defined by (2.14):

$$\mathbf{H}_{\text{int}} = \frac{\Delta_r}{2} \sigma_z + \frac{v e^{i\omega_r t} + v^* e^{-i\omega_r t}}{2} e^{\frac{i\omega_r t}{2} \sigma_z} \sigma_x e^{-\frac{i\omega_r t}{2} \sigma_z}.$$

With the identities $e^{i\theta\sigma_z} = \cos\theta\mathbf{I} + i\sin\theta\sigma_z$ and $\sigma_z\sigma_x = i\sigma_y$ we get the formula

$$e^{i\theta\sigma_z}\sigma_x e^{-i\theta\sigma_z} = e^{2i\theta}\sigma_+ + e^{-2i\theta}\sigma_-.$$

Thus we have

$$\mathbf{H}_{\text{int}} = \frac{\Delta_r}{2}\sigma_z + \frac{ve^{2i\omega_r t} + v^*}{2}\sigma_+ + \frac{v^*e^{-2i\omega_r t} + v}{2}\sigma_-.$$

The decomposition of $\mathbf{H}_{\text{int}} = \mathbf{H}_{\text{rwa}}^{\text{1st}} + \frac{d}{dt}\mathbf{I}_{\text{osc}}$ reads:

$$\mathbf{H}_{\text{int}} = \underbrace{\frac{\Delta_r}{2}\sigma_z + \frac{v^*}{2}\sigma_+ + \frac{v}{2}\sigma_-}_{\mathbf{H}_{\text{rwa}}^{\text{1st}}} + \underbrace{\frac{ve^{2i\omega_r t}}{2}\sigma_+ + \frac{v^*e^{-2i\omega_r t}}{2}\sigma_-}_{\frac{d}{dt}\mathbf{I}_{\text{osc}}}.$$

Thus the first order approximation of any solution $|\psi\rangle$ of

$$i\frac{d}{dt}|\psi\rangle = \left(\frac{\omega_r + \Delta_r}{2}\sigma_z + \frac{ve^{i\omega_r t} + v^*e^{-i\omega_r t}}{2}\sigma_x \right) |\psi\rangle$$

is given by $e^{-i\frac{\omega_r t}{2}}|\phi\rangle$ where $|\phi\rangle$ is solution of the linear time-invariant equation

$$i\frac{d}{dt}|\phi\rangle = \left(\frac{\Delta_r}{2}\sigma_z + \frac{v^*}{2}\sigma_+ + \frac{v}{2}\sigma_- \right) |\phi\rangle, \quad |\phi\rangle_0 = |\psi\rangle_0. \quad (2.17)$$

According to (2.15) the second order approximation requires the computation of the secular term in $\mathbf{I}_{\text{osc}}\frac{d}{dt}\mathbf{I}_{\text{osc}}$. Since $\mathbf{I}_{\text{osc}} = \frac{ve^{2i\omega_r t}}{4i\omega_r}\sigma_+ - \frac{v^*e^{-2i\omega_r t}}{4i\omega_r}\sigma_-$, we have

$$\mathbf{I}_{\text{osc}}\frac{d}{dt}\mathbf{I}_{\text{osc}} = \frac{|v|^2}{8i\omega_r}\sigma_z$$

where we have also applied $\sigma_+^2 = \sigma_-^2 = 0$ and $\sigma_z = \sigma_+\sigma_- - \sigma_-\sigma_+$. The second order approximation resulting from (2.15) reads:

$$i\frac{d}{dt}|\phi\rangle = \left(\left(\frac{\Delta_r}{2} + \frac{|v|^2}{8\omega_r} \right) \sigma_z + \frac{v^*}{2}\sigma_+ + \frac{v}{2}\sigma_- \right) |\phi\rangle, \quad |\phi\rangle_0 = |\psi\rangle_0. \quad (2.18)$$

We observe that (2.17) and (2.18) differ only by a correction of $\frac{|v|^2}{4\omega_r}$ added to the detuning Δ_r . This correction is called the Bloch-Siegert shift.

Set $v = \Omega_r e^{i\theta}$ and $\Delta'_r = \Delta_r + \frac{\Omega_r^2}{4\omega_r}$ with $\Omega_r > 0$ and θ real and constant. Then

$$\left(\left(\frac{\Delta_r}{2} + \frac{|v|^2}{8\omega_r} \right) \sigma_z + \frac{v^*}{2}\sigma_+ + \frac{v}{2}\sigma_- \right) = \frac{\Omega_r}{2} (\cos\theta\sigma_x + \sin\theta\sigma_y) + \frac{\Delta'_r}{2}\sigma_z. \quad (2.19)$$

Set

$$\Omega'_r = \sqrt{\left(\Delta_r + \frac{\Omega_r^2}{4\omega_r} \right)^2 + \Omega_r^2}, \quad \sigma_r = \frac{\Omega_r (\cos\theta\sigma_x + \sin\theta\sigma_y) + \Delta'_r\sigma_z}{\Omega'_r}.$$

Then $\sigma_r^2 = \mathbf{I}$ and thus the solution of (2.18),

$$|\phi\rangle_t = e^{-i\frac{\Omega'_r t}{2}}\sigma_r |\phi\rangle_0 = \cos\left(\frac{\Omega'_r t}{2}\right) |\phi\rangle_0 - i\sin\left(\frac{\Omega'_r t}{2}\right) \sigma_r |\phi\rangle_0,$$

oscillates between $|\phi\rangle_0$ and $-i\sigma_r|\phi\rangle_0$ with the Rabi frequency $\frac{\Omega'_r}{2}$.

For $\Delta_r = 0$ and neglecting second order terms in Ω_r , we have $\Omega'_r \approx \Omega_r$, $\Delta'_r \approx 0$ and $\sigma_r \approx \cos \theta \sigma_x + \sin \theta \sigma_y$. When $|\phi\rangle_0 = |g\rangle$ we see that, up-to second order terms, $|\phi\rangle_t$ oscillates between $|g\rangle$ and $e^{-i(\theta+\frac{\pi}{2})}|e\rangle$. With $\theta = -\frac{\pi}{2}$, we have

$$|\chi\rangle_t = \cos\left(\frac{\Omega_r t}{2}\right) |g\rangle + \sin\left(\frac{\Omega_r t}{2}\right) |e\rangle,$$

and we see that, with a constant amplitude $v = \Omega_r e^{i\eta}$ for $t \in [0, T]$, we have the following transition, depending on the pulse-length $T > 0$:

- if $\Omega_r T = \pi$ then $|\phi\rangle_T = |e\rangle$ and we have a transition between the ground state to the excited one, together with stimulated absorption of a photon of energy ω_{eg} . If we measure the energy in the final state we always find E_e . This is a π -pulse in reference to the Bloch sphere interpretation of (2.18) (see Subsection 1.2.2).
- if $\Omega_r T = \frac{\pi}{2}$ then $|\phi\rangle_T = (|g\rangle + |e\rangle)/\sqrt{2}$ and the final state is a coherent superposition of $|g\rangle$ and $|e\rangle$. A measure of the energy of the final state yields either E_g or E_e with a probability of 1/2 for both E_g and E_e . This is a $\frac{\pi}{2}$ -pulse.

Since $|\psi\rangle = e^{-\frac{i\omega_r t}{2}\sigma_z} |\phi\rangle$, we see that a π -pulse transfers $|\psi\rangle$ from $|g\rangle$ at $t = 0$ to $e^{i\alpha}|e\rangle$ at $t = T = \frac{\pi}{\Omega_r}$ where the phase $\alpha \approx \frac{\omega_r}{\Omega_r}\pi$ is very large since $\Omega_r \ll \omega_r$. Similarly, a $\frac{\pi}{2}$ -pulse, transfers $|\psi\rangle$ from $|g\rangle$ at $t = 0$ to $\frac{e^{-i\alpha}|g\rangle + e^{i\alpha}|e\rangle}{\sqrt{2}}$ at $t = T = \frac{\pi}{2\Omega_r}$ with a very large relative half-phase $\alpha \approx \frac{\omega_r}{2\Omega_r}\pi$.

Exercise 2. Take the first order approximation (2.17) with $\Delta_r = 0$ and $v \in \mathbb{C}$ as control.

1. Set $\Theta_r = \frac{\Omega_r T}{2}$. Show that the solution at T of the propagator $\mathbf{U}_t \in SU(2)$, $i\frac{d}{dt}\mathbf{U} = \frac{\Omega_r(\cos \theta \sigma_x + \sin \theta \sigma_y)}{2}\mathbf{U}$, $\mathbf{U}_0 = \mathbf{I}$ is given by

$$\mathbf{U}_T = \cos \Theta_r \mathbf{I} - i \sin \Theta_r (\cos \theta \sigma_x + \sin \theta \sigma_y),$$

2. Take a wave function $|\bar{\phi}\rangle$. Show that there exist Ω_r and θ such that $\mathbf{U}_T|g\rangle = e^{i\alpha}|\bar{\phi}\rangle$, where α is some global phase.
3. Prove that for any given two wave functions $|\phi_a\rangle$ and $|\phi_b\rangle$ exists a piece-wise constant control $[0, 2T] \ni t \mapsto v(t) \in \mathbb{C}$ such that the solution of (2.17) with $|\phi\rangle_0 = |\phi_a\rangle$ and $\Delta_r = 0$ satisfies $|\phi\rangle_T = e^{i\beta}|\phi_b\rangle$ for some global phase β .
4. Generalize the above question when $|\phi\rangle$ obeys the second order approximation (2.18) with Δ_r as additional control.

2.1.5 Λ -systems and Raman transition

This transition strategy is used for a three-level Λ -system. In such a 3-level system defined on the Hilbert space $\mathcal{H} = \{c_g|g\rangle + c_e|e\rangle + c_f|f\rangle, (c_g, c_e, c_f) \in \mathbb{C}^3\}$, we assume the three energy levels $|g\rangle$, $|e\rangle$ and $|f\rangle$ to admit the energies E_g , E_e and E_f (see Figure 2.1). The atomic frequencies are denoted as follows:

$$\omega_{fg} = (E_f - E_g), \quad \omega_{fe} = (E_f - E_e), \quad \omega_{eg} = (E_e - E_g).$$

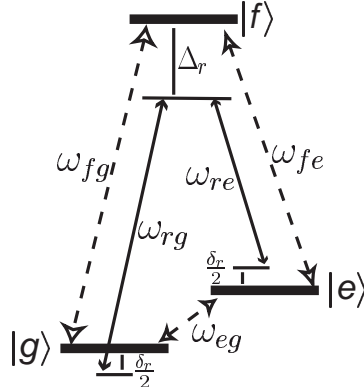

Figure 2.1: Raman transition for a Λ -level system ($\delta_r < 0$ and $\Delta_r > 0$ on the figure).

We assume a Hamiltonian of the form

$$\mathbf{H}(t) = E_g|g\rangle\langle g| + E_e|e\rangle\langle e| + E_f|f\rangle\langle f| + \frac{u(t)}{2} \left(\mu_g(|g\rangle\langle f| + |f\rangle\langle g|) + \mu_e(|e\rangle\langle f| + |f\rangle\langle e|) \right) \quad (2.20)$$

where μ_g and μ_e are coupling coefficients with the electromagnetic field described by $u(t)$. Assuming the third level $|f\rangle$ to admit an energy E_f much greater than E_e and E_g , we will see that the averaged Hamiltonian (after the rotating wave approximation) is very similar to the one describing Rabi oscillations and the state $|f\rangle$ can be ignored. The transition from $|g\rangle$ to $|e\rangle$ is no more performed via a quasi-resonant control with a single frequency close to $\omega_{eg} = (E_e - E_g)$, but with a control based on two frequencies ω_{rg} and ω_{re} , in a neighborhood of $\omega_{fg} = (E_f - E_g)$ and $\omega_{fe} = (E_f - E_e)$, with $\omega_{rg} - \omega_{re}$ close to ω_{eg} . Such transitions result from a nonlinear phenomena and second order perturbations. The main practical advantage comes from the fact that ω_{re} and ω_{rg} are in many examples optical frequencies (around 10^{15} rad/s) whereas ω_{eg} is a radio frequency (around 10^{10} rad/s). The wave length of the laser generating u is around $1 \mu\text{m}$ and thus spatial resolution is much better with optical waves than with radio-frequency ones.

Indeed, in the Hamiltonian (2.20), we take a quasi-resonant control defined by the constant complex amplitudes u_g and u_e ,

$$u(t) = u_g e^{i\omega_{rg}t} + u_g^* e^{-i\omega_{rg}t} + u_e e^{i\omega_{re}t} + u_e^* e^{-i\omega_{re}t}$$

where the frequencies ω_{rg} and ω_{re} are close to ω_{fg} and ω_{fe} . According to Figure 2.1 set

$$\omega_{fg} = \omega_{rg} + \Delta_r - \frac{\delta_r}{2}, \quad \omega_{fe} = \omega_{re} + \Delta_r + \frac{\delta_r}{2},$$

and assume that

$$\left(\max(|\mu_g|, |\mu_e|) \max(|u_g|, |u_e|) \right) \text{ and } |\delta_r| \ll \min(\omega_{rg}, \omega_{re}, \omega_{fg}, \omega_{fe}, |\Delta_r|, |\omega_{re} - \omega_{rg} + \Delta_r|, |\omega_{re} - \omega_{rg} - \Delta_r|).$$

In the interaction frame (passage from $|\psi\rangle$ where $i\frac{d}{dt}|\psi\rangle = \mathbf{H}(t)|\psi\rangle$ to $|\phi\rangle$),

$$|\psi\rangle = \left(e^{-i(E_g + \frac{\delta_r}{2})t} |g\rangle\langle g| + e^{-i(E_e - \frac{\delta_r}{2})t} |e\rangle\langle e| + e^{-iE_f t} |f\rangle\langle f| \right) |\phi\rangle$$

the Hamiltonian becomes ($i\frac{d}{dt}|\phi\rangle = \mathbf{H}_{\text{int}}(t)|\phi\rangle$):

$$\begin{aligned} \mathbf{H}_{\text{int}}(t) &= \frac{\delta_r}{2}(|e\rangle\langle e| - |g\rangle\langle g|) \\ &+ \mu_g (u_g e^{i\omega_{rg}t} + u_e e^{i\omega_{re}t} + u_g^* e^{-i\omega_{rg}t} + u_e^* e^{-i\omega_{re}t}) \left(e^{i(\omega_{rg}+\Delta_r)t} |g\rangle\langle f| + e^{-i(\omega_{rg}+\Delta_r)t} |f\rangle\langle g| \right) \\ &+ \mu_e (u_g e^{i\omega_{rg}t} + u_e e^{i\omega_{re}t} + u_g^* e^{-i\omega_{rg}t} + u_e^* e^{-i\omega_{re}t}) \left(e^{i(\omega_{re}+\Delta_r)t} |e\rangle\langle f| + e^{-i(\omega_{re}+\Delta_r)t} |f\rangle\langle e| \right). \end{aligned}$$

It is clear from (2.15), that $\mathbf{H}_{\text{rwa}}^{1\text{st}} = \frac{\delta_r}{2}(|e\rangle\langle e| - |g\rangle\langle g|)$ and thus second order terms should be considered and $\mathbf{H}_{\text{rwa}}^{2\text{nd}}$ has to be computed for a meaningful approximation. Simple but tedious computations show that $\int (\mathbf{H}_{\text{int}} - \mathbf{H}_{\text{rwa}}^{1\text{st}})$ (the time primitive of zero mean) is given by

$$\begin{aligned} &\frac{\mu_g}{2} \left(\frac{u_g e^{i(2\omega_{rg}+\Delta_r)t}}{i(2\omega_{rg}+\Delta_r)} + \frac{u_e e^{i(\omega_{rg}+\omega_{re}+\Delta_r)t}}{i(\omega_{rg}+\omega_{re}+\Delta_r)} + \frac{u_g^* e^{i\Delta_r t}}{i\Delta_r} + \frac{u_e^* e^{i(\omega_{rg}-\omega_{re}+\Delta_r)t}}{i(\omega_{rg}-\omega_{re}+\Delta_r)} \right) |g\rangle\langle f| \\ &+ \frac{\mu_e}{2} \left(\frac{u_g e^{i(\omega_{rg}+\omega_{re}+\Delta_r)t}}{i(\omega_{rg}+\omega_{re}+\Delta_r)} + \frac{u_e e^{i(2\omega_{re}+\Delta_r)t}}{i(2\omega_{re}+\Delta_r)} + \frac{u_g^* e^{i(\omega_{re}-\omega_{rg}+\Delta_r)t}}{i(\omega_{re}-\omega_{rg}+\Delta_r)} + \frac{u_e^* e^{i\Delta_r t}}{i\Delta_r} \right) |e\rangle\langle f| \\ &- \frac{\mu_g}{2} \left(\frac{u_g^* e^{-i(2\omega_{rg}+\Delta_r)t}}{i(2\omega_{rg}+\Delta_r)} + \frac{u_e^* e^{-i(\omega_{rg}+\omega_{re}+\Delta_r)t}}{i(\omega_{rg}+\omega_{re}+\Delta_r)} + \frac{u_g e^{-i\Delta_r t}}{i\Delta_r} + \frac{u_e e^{-i(\omega_{rg}-\omega_{re}+\Delta_r)t}}{i(\omega_{rg}-\omega_{re}+\Delta_r)} \right) |f\rangle\langle g| \\ &- \frac{\mu_e}{2} \left(\frac{u_g^* e^{-i(\omega_{rg}+\omega_{re}+\Delta_r)t}}{i(\omega_{rg}+\omega_{re}+\Delta_r)} + \frac{u_e^* e^{-i(2\omega_{re}+\Delta_r)t}}{i(2\omega_{re}+\Delta_r)} + \frac{u_g e^{-i(\omega_{re}-\omega_{rg}+\Delta_r)t}}{i(\omega_{re}-\omega_{rg}+\Delta_r)} + \frac{u_e e^{-i\Delta_r t}}{i\Delta_r} \right) |f\rangle\langle e|. \end{aligned}$$

The non-oscillating terms of $i\left(\int_t (\mathbf{H}_{\text{int}} - \mathbf{H}_{\text{rwa}}^{1\text{st}})\right) (\mathbf{H}_{\text{int}} - \mathbf{H}_{\text{rwa}}^{1\text{st}})$ are then given by simple but tedious computations:

$$\begin{aligned} \mathbf{H}_{\text{rwa}}^{2\text{nd}} &= \frac{\mu_g \mu_e}{4} \left(\frac{1}{\omega_{rg}+\omega_{re}+\Delta_r} + \frac{1}{\Delta_r} \right) (u_g^* u_e |g\rangle\langle e| + u_g u_e^* |e\rangle\langle g|) + \frac{\delta_r}{2} (|e\rangle\langle e| - |g\rangle\langle g|) \\ &+ \frac{\mu_g^2}{4} \left(\frac{|u_g|^2}{2\omega_{rg}+\Delta_r} + \frac{|u_g|^2}{\Delta_r} + \frac{|u_e|^2}{\omega_{rg}-\omega_{re}+\Delta_r} \right) |g\rangle\langle g| + \frac{\mu_e^2}{4} \left(\frac{|u_e|^2}{2\omega_{re}+\Delta_r} + \frac{|u_e|^2}{\Delta_r} + \frac{|u_g|^2}{\omega_{re}-\omega_{rg}+\Delta_r} \right) |e\rangle\langle e| \\ &- \frac{1}{4} \left(\frac{\mu_g^2 |u_g|^2}{2\omega_{rg}+\Delta_r} + \frac{\mu_e^2 |u_e|^2}{2\omega_{re}+\Delta_r} + \frac{\mu_g^2 |u_g|^2 + \mu_e^2 |u_e|^2}{\omega_{rg}+\omega_{re}+\Delta_r} + \frac{\mu_g^2 |u_g|^2 + \mu_e^2 |u_e|^2}{\Delta_r} + \frac{\mu_g^2 |u_g|^2}{\omega_{re}-\omega_{rg}+\Delta_r} + \frac{\mu_e^2 |u_e|^2}{\omega_{rg}-\omega_{re}+\Delta_r} \right) |f\rangle\langle f|. \end{aligned} \tag{2.21}$$

This expression simplifies if we assume additionally that

$$|\Delta_r|, |\omega_{re} - \omega_{rg} + \Delta_r|, |\omega_{re} - \omega_{rg} - \Delta_r| \ll \omega_{rg}, \omega_{re}, \omega_{fg}, \omega_{fe}.$$

With these additional assumptions we have 3 time-scales:

1. The slow one associated to δ_r , $\mu_g |u_g|$, $\mu_g |u_e|$, $\mu_e |u_g|$ and $\mu_e |u_e|$
2. The intermediate one attached to Δ_r , $|\omega_{re} - \omega_{rg} + \Delta_r|$ and $|\omega_{re} - \omega_{rg} - \Delta_r|$
3. The fast one related to ω_{rg} , ω_{re} , ω_{fg} and ω_{fe} .

We have then the following approximation of the average Hamiltonian

$$\begin{aligned} \mathbf{H}_{\text{rwa}}^{2\text{nd}} &\approx \frac{\mu_g \mu_e u_g^* u_e}{4\Delta_r} |g\rangle\langle e| + \frac{\mu_g \mu_e u_g u_e^*}{4\Delta_r} |e\rangle\langle g| + \frac{\delta_r}{2} (|e\rangle\langle e| - |g\rangle\langle g|) \\ &+ \frac{\mu_g^2}{4} \left(\frac{|u_g|^2}{\Delta_r} + \frac{|u_e|^2}{\omega_{rg}-\omega_{re}+\Delta_r} \right) |g\rangle\langle g| + \frac{\mu_e^2}{4} \left(\frac{|u_e|^2}{\Delta_r} + \frac{|u_g|^2}{\omega_{re}-\omega_{rg}+\Delta_r} \right) |e\rangle\langle e| \\ &- \frac{1}{4} \left(\frac{\mu_g^2 |u_g|^2 + \mu_e^2 |u_e|^2}{\Delta_r} + \frac{\mu_g^2 |u_g|^2}{\omega_{re}-\omega_{rg}+\Delta_r} + \frac{\mu_e^2 |u_e|^2}{\omega_{rg}-\omega_{re}+\Delta_r} \right) |f\rangle\langle f|. \end{aligned}$$

If $\langle \phi | f \rangle_0 = 0$ then $\langle \phi | f \rangle_t = 0$ up to third order terms: the space $\text{span}\{|g\rangle, |e\rangle\}$ and $\text{span}\{|f\rangle\}$ are invariant space of $\mathbf{H}_{\text{rwa}}^{2\text{nd}}$. Thus, if the initial state belongs to $\text{span}\{|g\rangle, |e\rangle\}$, we can forget the $|f\rangle\langle f|$ term in $\mathbf{H}_{\text{rwa}}^{2\text{nd}}$ (restriction of the dynamics to this invariant subspace) and we get a 2-level Hamiltonian, called Raman Hamiltonian, that lives on $\text{span}\{|g\rangle, |e\rangle\}$:

$$\begin{aligned} \mathbf{H}_{\text{Raman}} = & \frac{\mu_g \mu_e u_g^* u_e}{4\Delta_r} |g\rangle\langle e| + \frac{\mu_g \mu_e u_g u_e^*}{4\Delta_r} |e\rangle\langle g| + \frac{\delta_r}{2} (|e\rangle\langle e| - |g\rangle\langle g|) \\ & + \frac{\mu_g^2}{4} \left(\frac{|u_g|^2}{\Delta_r} + \frac{|u_e|^2}{\omega_{rg} - \omega_{re} + \Delta_r} \right) |g\rangle\langle g| + \frac{\mu_e^2}{4} \left(\frac{|u_e|^2}{\Delta_r} + \frac{|u_g|^2}{\omega_{re} - \omega_{rg} + \Delta_r} \right) |e\rangle\langle e|. \end{aligned} \quad (2.22)$$

that is similar (up to a global phase shift) to the average Hamiltonian underlying Rabi oscillations (2.19) with

$$\begin{aligned} \Delta'_r &= \delta_r + \frac{\mu_e^2}{4} \left(\frac{|u_e|^2}{\Delta_r} + \frac{|u_g|^2}{\omega_{re} - \omega_{rg} + \Delta_r} \right) - \frac{\mu_g^2}{4} \left(\frac{|u_g|^2}{\Delta_r} + \frac{|u_e|^2}{\omega_{rg} - \omega_{re} + \Delta_r} \right), \\ \Omega_r e^{i\theta} &= \frac{\mu_g \mu_e u_g^* u_e}{2\Delta_r}. \end{aligned}$$

During such Raman pulses, the intermediate state $|f\rangle$ remains almost empty (i.e. $\langle \psi | f \rangle \approx 0$) and thus, this protocol remains rather robust with respect to an eventual instability of the state $|f\rangle$, not modeled through such Schrödinger dynamics. To tackle such questions, one has to consider non-conservative dynamics for $|\psi\rangle$ and to take into account decoherence effects due to the coupling of $|f\rangle$ with the environment, coupling leading to a finite lifetime. The incorporation into the $|\psi\rangle$ -dynamics of such irreversible effects, is analogous to the incorporation of friction and viscous effects in classical Hamiltonian dynamics. Later on through these lecture notes, we will present such models to describe open quantum systems (see also chapter 4 of [36] for a tutorial exposure and [16, 3] for more mathematical presentations).

2.1.6 Jaynes-Cummings model

Consider the resonant Jaynes-Cummings Hamiltonian \mathbf{H}_{res} of Subsection 1.3.1 that governs the dynamics of $|\psi\rangle$,

$$i \frac{d}{dt} |\psi\rangle = \left(\frac{\omega_{\text{eg}}}{2} \boldsymbol{\sigma}_z + \omega_c \left(\mathbf{a}^\dagger \mathbf{a} + \frac{\mathbf{I}}{2} \right) + u(t) (\mathbf{a} + \mathbf{a}^\dagger) + i \frac{\Omega}{2} \boldsymbol{\sigma}_x (\mathbf{a}^\dagger - \mathbf{a}) \right) |\psi\rangle,$$

where we have additionally considered a drive of real amplitude $u(t)$ applied on the harmonic oscillator. Assume that $u(t) = v e^{i\omega_r t} + v^* e^{-i\omega_r t}$ where the complex amplitude v is constant. Define the following detunings

$$\Delta_c = \omega_c - \omega_r, \quad \Delta_{\text{eg}} = \omega_{\text{eg}} - \omega_r$$

and assume that

$$|\Delta_c|, |\Delta_{\text{eg}}|, |\Omega|, |v| \ll \omega_{\text{eg}}, \omega_c, \omega_r.$$

Then $\mathbf{H}_{\text{res}} = \mathbf{H}_0 + \epsilon \mathbf{H}_1$ where ϵ is a small parameter and

$$\begin{aligned} \mathbf{H}_0 &= \frac{\omega_r}{2} \boldsymbol{\sigma}_z + \omega_r \left(\mathbf{a}^\dagger \mathbf{a} + \frac{\mathbf{I}}{2} \right) \\ \epsilon \mathbf{H}_1 &= \left(\frac{\Delta_{\text{eg}}}{2} \boldsymbol{\sigma}_z + \Delta_c \left(\mathbf{a}^\dagger \mathbf{a} + \frac{\mathbf{I}}{2} \right) + (v e^{i\omega_r t} + v^* e^{-i\omega_r t}) (\mathbf{a} + \mathbf{a}^\dagger) + i \frac{\Omega}{2} \boldsymbol{\sigma}_x (\mathbf{a}^\dagger - \mathbf{a}) \right). \end{aligned}$$

Even if we the system is infinite dimensional, we apply here heuristically the rotating wave approximation summarized in Subsection 2.1.2. First we have to compute the Hamiltonian in the interaction frame via the following change of variables $|\psi\rangle \mapsto |\phi\rangle$:

$$|\psi\rangle = e^{-i\omega_r t(\mathbf{a}^\dagger \mathbf{a} + \frac{\mathbf{I}}{2})} e^{\frac{-i\omega_r t}{2} \sigma_z} |\phi\rangle$$

We get the following interaction Hamiltonian

$$\begin{aligned} \mathbf{H}_{\text{int}} = \frac{\Delta_{eg}}{2} \sigma_z + \Delta_c \left(\mathbf{a}^\dagger \mathbf{a} + \frac{\mathbf{I}}{2} \right) + (v e^{i\omega_r t} + v^* e^{-i\omega_r t}) (e^{-i\omega_r t} \mathbf{a} + e^{i\omega_r t} \mathbf{a}^\dagger) \\ + i \frac{\Omega}{2} (e^{-i\omega_r t} \sigma_- + e^{i\omega_r t} \sigma_+) (e^{i\omega_r t} \mathbf{a}^\dagger - e^{-i\omega_r t} \mathbf{a}) \end{aligned}$$

where we have applied the following identities (see Subsections 1.2.1 and 1.1.2):

$$e^{\frac{i\theta}{2} \sigma_z} \sigma_x e^{-\frac{i\theta}{2} \sigma_z} = e^{-i\theta} \sigma_- + e^{i\theta} \sigma_+, \quad e^{i\theta(\mathbf{a}^\dagger \mathbf{a} + \frac{\mathbf{I}}{2})} \mathbf{a} e^{-i\theta(\mathbf{a}^\dagger \mathbf{a} + \frac{\mathbf{I}}{2})} = e^{-i\theta} \mathbf{a}$$

The secular part of \mathbf{H}_{int} is given by

$$\mathbf{H}_{\text{rwa}}^{1\text{st}} = \frac{\Delta_{eg}}{2} \sigma_z + \Delta_c \left(\mathbf{a}^\dagger \mathbf{a} + \frac{\mathbf{I}}{2} \right) + v \mathbf{a} + v^* \mathbf{a}^\dagger + i \frac{\Omega}{2} (\sigma_- \mathbf{a}^\dagger - \sigma_+ \mathbf{a}) \quad (2.23)$$

and its oscillating part by

$$(\mathbf{H}_{\text{int}} - \mathbf{H}_{\text{rwa}}^{1\text{st}}) = v e^{2i\omega_r t} \mathbf{a}^\dagger + v^* e^{-2i\omega_r t} \mathbf{a} + i \frac{\Omega}{2} (e^{2i\omega_r t} \sigma_+ \mathbf{a}^\dagger - e^{-2i\omega_r t} \sigma_- \mathbf{a}).$$

Then we have

$$\int_t (\mathbf{H}_{\text{int}} - \mathbf{H}_{\text{rwa}}^{1\text{st}}) = \frac{1}{2i\omega_r} \left(v e^{2i\omega_r t} \mathbf{a}^\dagger - v^* e^{-2i\omega_r t} \mathbf{a} + i \frac{\Omega}{2} (e^{2i\omega_r t} \sigma_+ \mathbf{a}^\dagger + e^{-2i\omega_r t} \sigma_- \mathbf{a}) \right)$$

and, following (2.15), the second order approximation reads

$$\begin{aligned} \mathbf{H}_{\text{rwa}}^{2\text{nd}} = \frac{\Delta_{eg} + \frac{\Omega^2}{8\omega_r}}{2} \sigma_z + \Delta_c \left(\mathbf{a}^\dagger \mathbf{a} + \frac{\mathbf{I}}{2} \right) + v \mathbf{a} + v^* \mathbf{a}^\dagger + i \frac{\Omega}{2} (\sigma_- \mathbf{a}^\dagger - \sigma_+ \mathbf{a}) \\ + i \frac{\Omega}{4\omega_r} (v \sigma_- - v^* \sigma_+) + \frac{\Omega^2}{8\omega_r} \sigma_z \mathbf{a}^\dagger \mathbf{a} - \left(\frac{\Omega^2}{16\omega_r} + \frac{|v|^2}{2\omega_r} \right) \mathbf{I} \end{aligned} \quad (2.24)$$

(use $[\mathbf{a}, \mathbf{a}^\dagger] = 1$, $\sigma_+ \sigma_- = |e\rangle\langle e|$ and $\sigma_- \sigma_+ = |g\rangle\langle g|$).

Consider now that the average Hamiltonian $\mathbf{H}_{\text{rwa}}^{1\text{st}}$ defined by (2.23) with $v \in \mathbb{C}$ as control. It splits into $\mathbf{H}_0 + v_1 \mathbf{H}_1 + v_2 \mathbf{H}_2$ where $v = \frac{1}{2}(v_1 + i v_2)$ with $v_1, v_2 \in \mathbb{R}$ and

$$\mathbf{H}_0 = \frac{\Delta_{eg}}{2} \sigma_z + \Delta_c (\mathbf{X}^2 + \mathbf{P}^2) - \frac{\Omega}{2} (\mathbf{X} \sigma_y + \mathbf{P} \sigma_x), \quad \mathbf{H}_1 = \frac{\mathbf{a} + \mathbf{a}^\dagger}{2} = \mathbf{X}, \quad \mathbf{H}_2 = \frac{\mathbf{a} - \mathbf{a}^\dagger}{2i} = \mathbf{P}. \quad (2.25)$$

With the commutation rules for the Pauli matrices $\sigma_{x,y,z}$ and the Heisenberg commutation relation $[\mathbf{X}, \mathbf{P}] = \frac{i}{2}$, the Lie algebra spanned by $i\mathbf{H}_0$, $i\mathbf{H}_1$ and $i\mathbf{H}_2$ is of infinite dimension. Thus, it is natural to wish that this system is controllable. To fix the problem, it is useful to write it in the form of partial differential equations where powerful tools exist for studying linear and nonlinear controllability (see, e.g. [27]). The controlled system $i \frac{d}{dt} |\phi\rangle = (\mathbf{H}_0 + v_1 \mathbf{H}_1 + v_2 \mathbf{H}_2) |\phi\rangle$ reads as a system of two partial differential equations, affine in the two

scalar controls $u_1 = v_1/\sqrt{2}$ and $u_2 = v_2/\sqrt{2}$. The quantum state $|\phi\rangle$ is described by two elements of $L^2(\mathbb{R}, \mathbb{C})$, ϕ_g and ϕ_e , whose time evolution is given by

$$\begin{aligned} i\frac{\partial\phi_g}{\partial t} &= -\frac{\Delta_c}{2}\frac{\partial^2\phi_g}{\partial x^2} + \left(\frac{\Delta_c x^2 - \Delta_{eg}}{2}\right)\phi_g + \left(u_1 x + iu_2\frac{\partial}{\partial x}\right)\phi_g + i\frac{\Omega}{2\sqrt{2}}\left(x + \frac{\partial}{\partial x}\right)\phi_e \\ i\frac{\partial\phi_e}{\partial t} &= -\frac{\Delta_c}{2}\frac{\partial^2\phi_e}{\partial x^2} + \left(\frac{\Delta_c x^2 + \Delta_{eg}}{2}\right)\phi_e + \left(u_1 x + iu_2\frac{\partial}{\partial x}\right)\phi_e - i\frac{\Omega}{2\sqrt{2}}\left(x - \frac{\partial}{\partial x}\right)\phi_g \end{aligned} \quad (2.26)$$

since \mathbf{X} stands for $\frac{x}{\sqrt{2}}$ and \mathbf{P} for $-\frac{i}{\sqrt{2}}\frac{\partial}{\partial x}$. An open question is the controllability on the set of functions (ϕ_g, ϕ_e) defined up to a global phase and such that $\|\phi_g\|_{L^2} + \|\phi_e\|_{L^2} = 1$. In a first step, one can take $\Delta_c = 0$ (which is not a limitation in fact) and $\Delta_{eg} = 0$ (which is a strict sub-case).

Exercise 3. Consider $i\frac{d}{dt}|\psi\rangle = (\mathbf{H}_0 + v_1\mathbf{H}_1 + v_2\mathbf{H}_2)|\psi\rangle$ with \mathbf{H}_0 , \mathbf{H}_1 and \mathbf{H}_2 given by (2.25) with $\Delta_{eg} = \Delta_c = 0$, $\Omega > 0$ and (v_1, v_2) as control. The system is therefore given by

$$i\frac{d}{dt}|\psi\rangle = \left(i\frac{\Omega}{2}(\sigma_- \mathbf{a}^\dagger - \sigma_+ \mathbf{a}) + v\mathbf{a}^\dagger + v^*\mathbf{a}\right)|\psi\rangle$$

with $v = \frac{v_1 + iv_2}{2}$.

1. Set $\nu \in \mathbb{C}$ solution of $\frac{d}{dt}\nu = -i\nu$ and consider the following change of frame $|\phi\rangle = \mathbf{D}_{-\nu}|\psi\rangle$ with the displacement operator $\mathbf{D}_{-\nu} = e^{-\nu\mathbf{a}^\dagger + \nu^*\mathbf{a}}$. Show that, up to a global phase change, we have

$$i\frac{d}{dt}|\phi\rangle = \left(\frac{i\Omega}{2}(\sigma_- \mathbf{a}^\dagger - \sigma_+ \mathbf{a}) + (\tilde{v}\sigma_+ + \tilde{v}^*\sigma_-)\right)|\phi\rangle$$

with $\tilde{v} = i\frac{\Omega}{2}\nu$.

2. Take the orthonormal basis $\{|g, n\rangle, |e, n\rangle\}$ with $n \in \mathbb{N}$ being the photon number and where for instance $|g, n\rangle$ stands for the tensor product $|g\rangle \otimes |n\rangle$. Set $|\phi\rangle = \sum_n \phi_{g,n}|g, n\rangle + \phi_{e,n}|e, n\rangle$ with $\phi_{g,n}, \phi_{e,n} \in \mathbb{C}$ depending on t and $\sum_n |\phi_{g,n}|^2 + |\phi_{e,n}|^2 = 1$. Show that, for $n \geq 0$

$$i\frac{d}{dt}\phi_{g,n+1} = i\frac{\Omega}{2}\sqrt{n+1}\phi_{e,n} + \tilde{v}^*\phi_{e,n+1}, \quad i\frac{d}{dt}\phi_{e,n} = -i\frac{\Omega}{2}\sqrt{n+1}\phi_{g,n+1} + \tilde{v}\phi_{g,n}$$

and $i\frac{d}{dt}\phi_{g,0} = \tilde{v}^*\phi_{e,0}$.

3. Assume that $|\phi\rangle_0 = |g, 0\rangle$. Construct an open-loop control $[0, T] \ni t \mapsto \tilde{v}(t)$ such that $|\phi\rangle_T = |g, 1\rangle$ (hint: take $\tilde{v} = \bar{v}\delta(t)$ and adjust the constants \bar{v} and $T > 0$, $\delta(t)$ Dirac distribution at 0).
4. Generalize the above open-loop control when the goal state $|\phi\rangle_T$ is $|g, n\rangle$ with any arbitrary photon number n .

2.1.7 Single trapped ion and Law-Eberly method

Through this subsection, we study the laser control of a single trapped ion as introduced in Subsection 1.3.2. The Hamiltonian is given by

$$\mathbf{H} = \frac{\omega_{\text{eg}}}{2} \boldsymbol{\sigma}_z + \omega_m (\mathbf{a}^\dagger \mathbf{a} + \frac{\mathbf{I}}{2}) + (u^*(t) \boldsymbol{\sigma}_+ e^{i\eta(\mathbf{a} + \mathbf{a}^\dagger)} + u(t) \boldsymbol{\sigma}_- e^{-i\eta(\mathbf{a} + \mathbf{a}^\dagger)}). \quad (2.27)$$

The Schrödinger equation $i \frac{d}{dt} |\psi\rangle = \tilde{\mathbf{H}} |\psi\rangle$ is equivalent to a system of partial differential equations on the two components (ψ_g, ψ_e) :

$$\begin{aligned} i \frac{\partial \psi_g}{\partial t} &= \frac{\omega_m}{2} \left(x^2 - \frac{\partial^2}{\partial x^2} \right) \psi_g - \frac{\omega_{\text{eg}}}{2} \psi_g + u(t) e^{-i\sqrt{2}\eta x} \psi_e \\ i \frac{\partial \psi_e}{\partial t} &= \frac{\omega_m}{2} \left(x^2 - \frac{\partial^2}{\partial x^2} \right) \psi_e + \frac{\omega_{\text{eg}}}{2} \psi_e + u^*(t) e^{i\sqrt{2}\eta x} \psi_g, \end{aligned} \quad (2.28)$$

where $u \in \mathbb{C}$ is the control input. In [32] this system is proven to be approximately controllable for (ψ_g, ψ_e) on the unit sphere of $(L^2(\mathbb{R}, \mathbb{C}))^2$. The proof proposed in [32] relies on the Law-Eberly proof of spectral controllability for a secular approximation when $u(t)$ is a superposition of three mono-chromatic plane waves: first one of frequency ω_{eg} (ion electronic transition) and amplitude v ; second one of frequency $\omega_{\text{eg}} - \omega_m$ (red shift by a vibration quantum) and amplitude v_r ; third one of frequency $\omega_{\text{eg}} + \omega_m$ (blue shift by a vibration quantum) and amplitude v_b . With this control, the Hamiltonian reads

$$\begin{aligned} \mathbf{H} &= \omega_m \left(\mathbf{a}^\dagger \mathbf{a} + \frac{\mathbf{I}}{2} \right) + \frac{\omega_{\text{eg}}}{2} \boldsymbol{\sigma}_z + \left(v \boldsymbol{\sigma}_- e^{i(\omega_{\text{eg}} t - \eta(\mathbf{a} + \mathbf{a}^\dagger))} + v^* \boldsymbol{\sigma}_+ e^{-i(\omega_{\text{eg}} t - \eta(\mathbf{a} + \mathbf{a}^\dagger))} \right) \\ &+ \left(v_b \boldsymbol{\sigma}_- e^{i((\omega_{\text{eg}} + \omega_m) t - \eta_b(\mathbf{a} + \mathbf{a}^\dagger))} + v_b^* \boldsymbol{\sigma}_+ e^{-i((\omega_{\text{eg}} + \omega_m) t - \eta_b(\mathbf{a} + \mathbf{a}^\dagger))} \right) \\ &+ \left(v_r \boldsymbol{\sigma}_- e^{i((\omega_{\text{eg}} - \omega_m) t - \eta_r(\mathbf{a} + \mathbf{a}^\dagger))} + v_r^* \boldsymbol{\sigma}_+ e^{-i((\omega_{\text{eg}} - \omega_m) t - \eta_r(\mathbf{a} + \mathbf{a}^\dagger))} \right). \end{aligned}$$

We have the following separation of scales (vibration frequency much smaller than the qubit frequency and slowly varying laser amplitudes v, v_r, v_b):

$$\omega_m \ll \omega_{\text{eg}}, \quad \left| \frac{d}{dt} \right| \ll \omega_m |v|, \quad \left| \frac{d}{dt} v_r \right| \ll \omega_m |v_r|, \quad \left| \frac{d}{dt} v_b \right| \ll \omega_m |v_b|.$$

Furthermore the Lamb-Dicke parameters $|\eta|, |\eta_b|, |\eta_r| \ll 1$ are almost identical. In the interaction frame, $|\psi\rangle$ is replaced by $|\phi\rangle$ according to

$$|\psi\rangle = e^{-i\omega t (\mathbf{a}^\dagger \mathbf{a} + \frac{\mathbf{I}}{2})} e^{-\frac{i\omega_{\text{eg}} t}{2} \boldsymbol{\sigma}_z} |\phi\rangle.$$

The Hamiltonian becomes

$$\begin{aligned} \mathbf{H}_{\text{int}} &= e^{i\omega_m t (\mathbf{a}^\dagger \mathbf{a})} \left(v \boldsymbol{\sigma}_- e^{-i\eta(\mathbf{a} + \mathbf{a}^\dagger)} + v^* \boldsymbol{\sigma}_+ e^{i\eta(\mathbf{a} + \mathbf{a}^\dagger)} \right) e^{-i\omega_m t (\mathbf{a}^\dagger \mathbf{a})} \\ &+ e^{i\omega t (\mathbf{a}^\dagger \mathbf{a})} \left(v_b \boldsymbol{\sigma}_- e^{i\omega_m t} e^{-i\eta_b(\mathbf{a} + \mathbf{a}^\dagger)} + v_b^* \boldsymbol{\sigma}_+ e^{-i\omega_m t} e^{i\eta_b(\mathbf{a} + \mathbf{a}^\dagger)} \right) e^{-i\omega_m t (\mathbf{a}^\dagger \mathbf{a})} \\ &+ e^{i\omega_m t (\mathbf{a}^\dagger \mathbf{a})} \left(v_r \boldsymbol{\sigma}_- e^{-i\omega_m t} e^{-i\eta_r(\mathbf{a} + \mathbf{a}^\dagger)} + v_r^* \boldsymbol{\sigma}_+ e^{i\omega_m t} e^{i\eta_r(\mathbf{a} + \mathbf{a}^\dagger)} \right) e^{-i\omega_m t (\mathbf{a}^\dagger \mathbf{a})}. \end{aligned}$$

With the approximation $e^{i\epsilon(a+a^\dagger)} \approx 1 + i\epsilon(a+a^\dagger)$ for $\epsilon = \pm\eta, \eta_b, \eta_r$, the Hamiltonian becomes (up to second order terms in ϵ),

$$\begin{aligned} \mathbf{H}_{\text{int}} = & v\sigma_{-}(1 - i\eta(e^{-i\omega_m t}\mathbf{a} + e^{i\omega_m t}\mathbf{a}^\dagger)) + v^*\sigma_{+}(1 + i\eta(e^{-i\omega_m t}\mathbf{a} + e^{i\omega_m t}\mathbf{a}^\dagger)) \\ & + v_b e^{i\omega_m t}\sigma_{-}(1 - i\eta_b(e^{-i\omega_m t}\mathbf{a} + e^{i\omega_m t}\mathbf{a}^\dagger)) + v_b^* e^{-i\omega_m t}\sigma_{+}(1 + i\eta_b(e^{-i\omega_m t}\mathbf{a} + e^{i\omega_m t}\mathbf{a}^\dagger)) \\ & + v_r e^{-i\omega_m t}\sigma_{-}(1 - i\eta_r(e^{-i\omega_m t}\mathbf{a} + e^{i\omega_m t}\mathbf{a}^\dagger)) + v_r^* e^{i\omega_m t}\sigma_{+}(1 + i\eta_r(e^{-i\omega_m t}\mathbf{a} + e^{i\omega_m t}\mathbf{a}^\dagger)) \end{aligned}$$

The oscillating terms (with frequencies $\pm\omega_m$ and $\pm 2\omega_m$) have zero average. The mean Hamiltonian, illustrated on Figure 2.2, reads

$$\mathbf{H}_{\text{rwa}}^{1\text{st}} = v\sigma_{-} + v^*\sigma_{+} + \bar{v}_b\mathbf{a}\sigma_{-} + \bar{v}_b^*\mathbf{a}^\dagger\sigma_{+} + \bar{v}_r\mathbf{a}^\dagger\sigma_{-} + \bar{v}_r^*\mathbf{a}\sigma_{+}$$

where we have set $\bar{v}_b = -i\eta_b v_b$ and $\bar{v}_r = -i\eta_r v_r$. The above Hamiltonian is "valid" as soon as $|\eta|, |\eta_b|, |\eta_r| \ll 1$ and

$$|v|, |v_b|, |v_r| \ll \omega_m, \quad \left| \frac{d}{dt}v \right| \ll \omega_m |v|, \quad \left| \frac{d}{dt}v_b \right| \ll \omega_m |v_b|, \quad \left| \frac{d}{dt}v_r \right| \ll \omega_m |v_r|.$$

To interpret the structure of the different operators building this average Hamiltonian, physicists have a nice mnemonic trick based on energy conservation. Take for example $\mathbf{a}\sigma_{-}$ attached to the control \bar{v}_b , i.e. to the blue shifted photon of frequency $\omega_{\text{eg}} + \omega_m$. The operator σ_{-} corresponds to the quantum jump from $|e\rangle$ to $|g\rangle$ whereas the operator \mathbf{a} is the destruction of one phonon. Thus $\mathbf{a}\sigma_{-}$ is the simultaneous jump from $|e\rangle$ to $|g\rangle$ (energy change of ω_{eg}) with destruction of one phonon (energy change of ω_m). The emitted photon has to take away the total energy lost by the system, i.e. $\omega_{\text{eg}} + \omega_m$. Its frequency is then $\omega_{\text{eg}} + \omega_m$ and corresponds thus to \bar{v}_b . We understand why $\mathbf{a}^\dagger\sigma_{-}$ is associated to \bar{v}_r : the system loses ω_{eg} during the jump from $|e\rangle$ to $|g\rangle$; at the same time, it wins ω_m , the phonon energy; the emitted photon takes away $\omega_{\text{eg}} - \omega_m$ and thus corresponds to \bar{v}_r . This point is illustrated on Figure 2.2 describing the first order transitions between the different states of definite energy.

The dynamics $i\frac{d}{dt}|\phi\rangle = \mathbf{H}_{\text{rwa}}^{1\text{st}}|\phi\rangle$ depends linearly on 6 scalar controls: it is a drift-less system of infinite dimension (non-holonomic system of infinite dimension). The two underlying partial differential equations are

$$\begin{aligned} i\frac{\partial\phi_g}{\partial t} &= \left(v + \frac{\bar{v}_b}{\sqrt{2}} \left(x + \frac{\partial}{\partial x} \right) + \frac{\bar{v}_r}{\sqrt{2}} \left(x - \frac{\partial}{\partial x} \right) \right) \phi_e \\ i\frac{\partial\phi_e}{\partial t} &= \left(v^* + \frac{\bar{v}_b^*}{\sqrt{2}} \left(x - \frac{\partial}{\partial x} \right) + \frac{\bar{v}_r^*}{\sqrt{2}} \left(x + \frac{\partial}{\partial x} \right) \right) \phi_g \end{aligned}$$

We write the above dynamics in the eigenbasis, $\{|g, n\rangle, |e, n\rangle\}_{n \in \mathbb{N}}$, of the operator $\omega_m(\mathbf{a}^\dagger\mathbf{a} + \frac{\mathbf{I}}{2}) + \frac{\omega_{\text{eg}}}{2}\sigma_z$:

$$\begin{aligned} i\frac{d}{dt}\phi_{g,n} &= v\phi_{e,n} + \bar{v}_r\sqrt{n}\phi_{e,n-1} + \bar{v}_b\sqrt{n+1}\phi_{e,n+1} \\ i\frac{d}{dt}\phi_{e,n} &= v^*\phi_{g,n} + \bar{v}_r^*\sqrt{n+1}\phi_{g,n+1} + \bar{v}_b^*\sqrt{n}\phi_{g,n-1} \end{aligned}$$

with $|\phi\rangle = \sum_{n=0}^{+\infty} \phi_{g,n}|g, n\rangle + \phi_{e,n}|e, n\rangle$ and $\sum_{n=0}^{+\infty} |\phi_{g,n}|^2 + |\phi_{e,n}|^2 = 1$.

Law and Eberly [?] illustrated that it is always possible (and in any arbitrary time $T > 0$) to steer $|\phi\rangle$ from any finite linear superposition of $\{|g, n\rangle, |e, n\rangle\}_{n \in \mathbb{N}}$ at $t = 0$, to any other

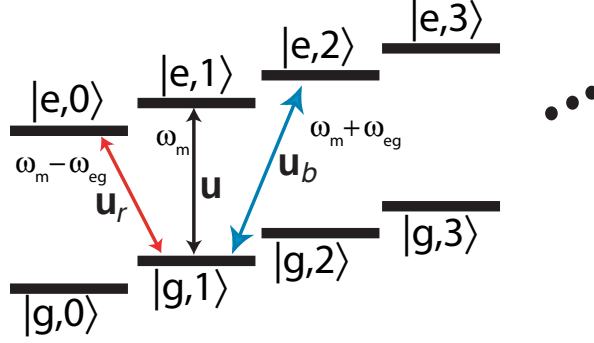

Figure 2.2: a trapped ion submitted to three mono-chromatic plane waves of frequencies ω_{eg} , $\omega_{eg} - \omega_m$ and $\omega_{eg} + \omega_m$.

finite linear superposition at time $t = T$ (spectral controllability). One only needs two controls v and \bar{v}_b (resp. v and \bar{v}_r): \bar{v}_r (resp. \bar{v}_b) remains zero and the supports of v and \bar{v}_b (resp. v and \bar{v}_r) do not overlap. This spectral controllability implies approximate controllability.

Let us detail now the main idea behind the Law-Eberly method to prove spectral controllability. Take $n > 0$ and denote by \mathcal{H}_n the truncation to n -phonon space:

$$\mathcal{H}_n = \text{span} \{|g, 0\rangle, |e, 0\rangle, \dots, |g, n\rangle, |e, n\rangle\}$$

We consider an initial condition $|\phi\rangle_0 \in \mathcal{H}_n$ and $T > 0$. Then for $t \in [0, \frac{T}{2}]$ the control

$$\bar{v}_r(t) = \bar{v}_b(t) = 0, \quad v(t) = \frac{2i}{T} \arctan \left| \frac{\phi_{e,n}(0)}{\phi_{g,n}(0)} \right| e^{i \arg(\phi_{g,n}(0)\phi_{e,n}^*(0))}$$

ensures that $\phi_{e,n}(T/2) = 0$. For $t \in [\frac{T}{2}, T]$, the control

$$\bar{v}_b(t) = v(t) = 0, \quad \bar{v}_r(t) = \frac{2i}{T\sqrt{n}} \arctan \left| \frac{\phi_{g,n}(\frac{T}{2})}{\phi_{e,n-1}(\frac{T}{2})} \right| e^{i \arg(\phi_{g,n}(\frac{T}{2})\phi_{e,n-1}^*(\frac{T}{2}))}$$

ensures that $\phi_{e,n}(t) \equiv 0$ and that $\phi_{g,n}(T) = 0$. Thus with this two-pulse control, the first one on v and the second one on \bar{v}_r , we have $|\phi\rangle_T \in \mathcal{H}_{n-1}$.

After n iterations of this two-pulse process $|\phi\rangle_{nT}$ belongs to \mathcal{H}_0 . Then for $t \in [nT, (n + \frac{1}{2})T]$, the control

$$\bar{v}_r(t) = \bar{v}_b(t) = 0, \quad v(t) = \frac{2i}{T} \arctan \left| \frac{\phi_{e,0}(nT)}{\phi_{g,0}(nT)} \right| e^{i \arg(\phi_{g,0}(nT)\phi_{e,0}^*(nT))}$$

guaranties that $|\phi\rangle_{(n+\frac{1}{2})T} = e^{i\theta}|g, 0\rangle$.

Up to a global phase, we can steer, in any arbitrary time and with a piecewise constant control, any element of \mathcal{H}_n to $|g, 0\rangle$. Since the system is driftless ($t \mapsto -t$ and $(v, \bar{v}_b, \bar{v}_r) \mapsto -(v, \bar{v}_b, \bar{v}_r)$ leave the system unchanged) we can easily reverse the time and thus can also steer $|g, 0\rangle$ to any element of \mathcal{H}_n . To steer $|\phi\rangle$ from any initial state in \mathcal{H}_n to any final state also in \mathcal{H}_n , it is enough to steer the initial state to $|g, 0\rangle$ and then to steer $|g, 0\rangle$ to the final state. To summarize: on can always steer, with piecewise constant controls and in an arbitrary short time, any finite linear superposition of $(|g, \nu\rangle, |e, \nu\rangle)_{\nu \geq 0}$ to any other one.

2.2 Adiabatic control

2.2.1 Time-adiabatic approximation without gap conditions

We first recall the quantum version of adiabatic invariance. We restrict here the exposure to finite dimensions and without the exponentially precise estimations. However we give the simplest version of a time-adiabatic approximation result without any gap conditions. All the details can be found in a recent book by Teufel [63] with extension to infinite dimensional case.

Theorem 1. *Take $m + 1$ Hermitian matrices of size $n \times n$: $\mathbf{H}_0, \dots, \mathbf{H}_m$. For $u \in \mathbb{R}^m$ set $H(u) := \mathbf{H}_0 + \sum_{k=1}^m u_k \mathbf{H}_k$. Assume that u is a slowly varying time-function: $u = u(s)$ with $s = \epsilon t \in [0, 1]$ and ϵ a small positive parameter. Consider a solution $[0, \frac{1}{\epsilon}] \ni t \mapsto |\psi\rangle_t^\epsilon$ of*

$$i \frac{d}{dt} |\psi\rangle_t^\epsilon = \mathbf{H}(u(\epsilon t)) |\psi\rangle_t^\epsilon.$$

Take $[0, s] \ni s \mapsto \mathbf{P}(s)$ a family of orthogonal projectors such that for each $s \in [0, 1]$, $\mathbf{H}(u(s))\mathbf{P}(s) = E(s)\mathbf{P}(s)$ where $E(s)$ is an eigenvalue of $\mathbf{H}(u(s))$. Assume that $[0, s] \ni s \mapsto \mathbf{H}(u(s))$ is C^2 , $[0, s] \ni s \mapsto \mathbf{P}(s)$ is C^2 and that, for almost all $s \in [0, 1]$, $\mathbf{P}(s)$ is the orthogonal projector on the eigenspace associated to the eigenvalue $E(s)$. Then

$$\lim_{\epsilon \rightarrow 0^+} \left(\sup_{t \in [0, \frac{1}{\epsilon}]} \left| \|\mathbf{P}(\epsilon t) |\psi\rangle_t^\epsilon\|^2 - \|\mathbf{P}(0) |\psi\rangle_0^\epsilon\|^2 \right| \right) = 0.$$

This theorem is a finite dimensional version of Theorem 6.2, page 175, in [63] where, for simplicity sake, we have removed the so-called adiabatic Hamiltonian and adiabatic propagator that intertwines the spectral subspace of the slowly time-dependent Hamiltonian $\mathbf{H}(u(\epsilon t))$.

This theorem implies that the solution of $i \frac{d}{dt} |\psi\rangle = \mathbf{H}(u(\frac{t}{T})) |\psi\rangle$ follows the spectral decomposition of $\mathbf{H}(u(\frac{t}{T}))$ as soon as T is large enough and when $\mathbf{H}(u(\frac{t}{T}))$ does not admit multiple eigenvalues (non-degenerate spectrum): apply the above theorem with $\mathbf{P} = \mathbf{P}_k$ where \mathbf{P}_k is the orthogonal projection on the k 'th eigenstate of \mathbf{H} to conclude that the population on state $|k\rangle$ is approximatively constant. If, for instance, $|\psi\rangle$ starts at $t = 0$ in the ground state and if $u(0) = u(1)$ then $|\psi\rangle$ returns at $t = T$, up to a global phase (related to the Berry phase [58]), to the same ground state.

Whenever, for some value of s , the spectrum of $\mathbf{H}(u(s))$ becomes degenerate the above theorem says that the populations follow the smooth decomposition versus s of $\mathbf{H}(u(s))$. For example, assume that the spectrum of \mathbf{H} is not degenerate except at \bar{s} where only two eigenvalues become identical: for all s we assume that the n eigenvalues of $\mathbf{H}(u(s))$ are labeled according to their order

$$E_1(s) < E_2(s) < \dots < E_{\bar{k}}(s) \leq E_{\bar{k}+1}(s) < E_{k+2}(s) < \dots < E_n(s)$$

and $E_{\bar{k}}(s) = E_{\bar{k}+1}(s)$ only when $s = \bar{s}$ for some $\bar{k} \in \{1, \dots, n\}$. Since $s \mapsto \mathbf{H}(u(s))$ is smooth, there always exists a spectral decomposition of $\mathbf{H}(u(s))$ that is smooth versus s (this comes from the fact that the spectral decomposition of a Hermitian matrix depends smoothly on its entries). Thus we have only two cases:

1. the non-crossing case where $s \mapsto E_{\bar{k}}(s)$ and $s \mapsto E_{\bar{k}+1}(s)$ are smooth functions

2. the crossing case where

$$s \mapsto \begin{cases} E_{\bar{k}}(s), & \text{for } s \leq \bar{s}; \\ E_{\bar{k}+1}(s), & \text{for } s \geq \bar{s}. \end{cases} \quad \text{and} \quad s \mapsto \begin{cases} E_{\bar{k}+1}(s), & \text{for } s \leq \bar{s}; \\ E_{\bar{k}}(s), & \text{for } s \geq \bar{s}. \end{cases}$$

are smooth functions.

In the non-crossing case the projectors that satisfy the theorem's assumption are the orthogonal projectors $\mathbf{P}_k(s)$ on the k 'th eigen-direction associated to $E_k(s)$. In the crossing case, the projectors on the eigenspaces associated to $E_{\bar{k}}$ and $E_{\bar{k}+1}$ have to be exchanged when s passes through \bar{s} to guaranty at least the continuity of $\mathbf{P}_{\bar{k}}(s)$ and $\mathbf{P}_{\bar{k}+1}(s)$: for $s < \bar{s}$, $\mathbf{P}_{\bar{k}}$ (resp. $\mathbf{P}_{\bar{k}+1}$) is the projector of the eigenspace associated to $E_{\bar{k}}$ (resp. $E_{\bar{k}+1}$); for $s > \bar{s}$, $\mathbf{P}_{\bar{k}}$ (resp. $\mathbf{P}_{\bar{k}+1}$) is the projector of the eigenspace associated to $E_{\bar{k}+1}$ (resp. $E_{\bar{k}}$); for $s = \bar{s}$, $\mathbf{P}_{\bar{k}}$ and $\mathbf{P}_{\bar{k}+1}$ are extended by continuity and correspond to orthogonal projectors on two orthogonal eigen-directions that span the eigenspace of dimension two associated to $E_{\bar{k}}(\bar{s}) = E_{\bar{k}+1}(\bar{s})$.

2.2.2 Adiabatic motion on the Bloch sphere

Let us take a qubit system. Since we do not care for global phase, we will use the Bloch vector formulation of Subsection 1.2.2:

$$\frac{d}{dt}\vec{M} = (u\vec{i} + v\vec{j} + w\vec{k}) \times \vec{M}$$

where we assume that $\vec{B} = (u\vec{i} + v\vec{j} + w\vec{k})$, a vector in \mathbb{R}^3 , is the control (in magnetic resonance, \vec{B} is the magnetic field). We set $\omega \in \mathbb{R}$ and $\vec{B} = \omega\vec{b}$ where \vec{b} is a unit vector in \mathbb{R}^3 . Thus we have

$$\frac{d}{dt}\vec{M} = \omega\vec{b} \times \vec{M}, \quad \text{with, as control input, } \omega \in \mathbb{R}, \vec{b} \in \mathbb{S}^2.$$

Assume now that \vec{B} varies slowly: we take $T > 0$ large (i.e., $\omega T \gg 1$), and set $\omega(t) = \varpi\left(\frac{t}{T}\right)$, $\vec{b}(t) = \vec{\beta}\left(\frac{t}{T}\right)$ where ϖ and $\vec{\beta}$ depend regularly on $s = \frac{t}{T} \in [0, 1]$. Assume that, at $t = 0$, $\vec{M}_0 = \vec{\beta}(0)$. If, for any $s \in [0, 1]$, $\varpi(s) > 0$, then the trajectory of \vec{M} with the above control \vec{B} verifies: $\vec{M}(t) \approx \vec{\beta}\left(\frac{t}{T}\right)$, i.e. \vec{M} follows adiabatically the direction of \vec{B} . If $\vec{b}(T) = \vec{b}(0)$, i.e., if the control \vec{B} makes a loop between 0 and T ($\beta(0) = \beta(1)$) then \vec{M} follows the same loop (in direction).

To justify this point, it suffices to consider $|\psi\rangle$ that obeys the Schrödinger equation $i\frac{d}{dt}|\psi\rangle = \left(\frac{u}{2}\sigma_x + \frac{v}{2}\sigma_y + \frac{w}{2}\sigma_z\right)|\psi\rangle$ and to apply the adiabatic theorem of the previous subsection. The absence of spectrum degeneracy results from the fact that ϖ never vanishes and remains always strictly positive. The initial condition $\vec{M}_0 = \vec{\beta}(0)$ corresponds to $|\psi\rangle_0$ in the ground state of $\frac{u(0)}{2}\sigma_x + \frac{v(0)}{2}\sigma_y + \frac{w(0)}{2}\sigma_z$. Thus $|\psi\rangle_t$ follows the ground state of $\frac{u(t)}{2}\sigma_x + \frac{v(t)}{2}\sigma_y + \frac{w(t)}{2}\sigma_z$, i.e., $\vec{M}(t)$ follows $\vec{\beta}\left(\frac{t}{T}\right)$.

The assumption concerning the non degeneracy of the spectrum is important. If it is not satisfied, $|\psi\rangle_t$ can jump smoothly from one branch to another branch when some eigenvalues cross. In order to understand this phenomenon (analogue to monodromy), assume that $\varpi(s)$ vanishes only once at $\bar{s} \in]0, 1[$ with $\varpi(s) > 0$ (resp. < 0) for $s \in [0, \bar{s}[$ (resp. $s \in]\bar{s}, 1]$). Then, around $t = \bar{s}T$, $|\psi\rangle_t$ changes smoothly from the ground state to the excited state of $\mathbf{H}(t)$, since their energies coincide for $t = \bar{s}T$. With such a choice for ϖ , \vec{B} performs a loop if, additionally $\vec{b}(0) = -\vec{b}(1)$ and $\varpi(0) = -\varpi(1)$, whereas $|\psi\rangle_t$ does not. It starts from the ground state at

$t = 0$ and ends on the excited state at $t = T$. In fact, $\vec{M}(t)$ follows adiabatically the direction of $\vec{B}(t)$ for $t \in [0, \bar{s}T]$ and then the direction of $-\vec{B}(t)$ for $t \in [\bar{s}T, T]$. Such quasi-static motion planing method is particularly robust and widely used in practice. We refer to [72, 1] for related control theoretical results. In the following subsections we detail some important examples.

2.2.3 Stimulated Raman Adiabatic Passage (STIRAP)

Consider the Λ -system of Figure 2.1. The controlled Hamiltonian reads

$$\mathbf{H}(t) = \omega_g |g\rangle\langle g| + \omega_e |e\rangle\langle e| + \omega_f |f\rangle\langle f| + u(t) (\mu_{gf}(|g\rangle\langle f| + |f\rangle\langle g|) + \mu_{ef}(|e\rangle\langle f| + |f\rangle\langle e|)).$$

Assume $\omega_{gf} = \omega_f - \omega_g > \omega_{ef} = \omega_f - \omega_e > 0$. We take a quasi-periodic and small control involving perfect resonances with transitions $g \leftrightarrow f$ and $e \leftrightarrow f$:

$$u = u_{gf} \cos(\omega_{gf}t) + u_{ef} \cos(\omega_{ef}t)$$

with slowly varying small real amplitudes u_{gf} and u_{ef} . Put the system in the interaction frame via the unitary transformation $e^{-it(\omega_g|g\rangle\langle g| + \omega_e|e\rangle\langle e| + \omega_f|f\rangle\langle f|)}$. We apply the rotating wave approximation (order 1 in (2.15)) to get the average Hamiltonian

$$\mathbf{H}_{\text{rwa}}^{1\text{st}} = \frac{\Omega_{gf}}{2}(|g\rangle\langle f| + |f\rangle\langle g|) + \frac{\Omega_{ef}}{2}(|e\rangle\langle f| + |f\rangle\langle e|)$$

with slowly varying Rabi pulsations $\Omega_{gf} = \mu_{gf}u_{gf}$ and $\Omega_{ef} = \mu_{ef}u_{ef}$.

Let us now analyze the dependence of the spectral decomposition of $\mathbf{H}_{\text{rwa}}^{1\text{st}}$ on the two parameters Ω_{gf} and Ω_{ef} . When $\Omega_{gf}^2 + \Omega_{ef}^2 \neq 0$, spectrum of $\mathbf{H}_{\text{rwa}}^{1\text{st}}$ admits three distinct eigenvalues:

$$\Omega_- = -\frac{\sqrt{\Omega_{gf}^2 + \Omega_{ef}^2}}{2}, \quad \Omega_0 = 0, \quad \Omega_+ = \frac{\sqrt{\Omega_{gf}^2 + \Omega_{ef}^2}}{2}$$

associated to the following eigenvectors :

$$\begin{aligned} |-\rangle &= \frac{\Omega_{gf}}{\sqrt{2(\Omega_{gf}^2 + \Omega_{ef}^2)}} |g\rangle + \frac{\Omega_{ef}}{\sqrt{2(\Omega_{gf}^2 + \Omega_{ef}^2)}} |e\rangle - \frac{1}{\sqrt{2}} |f\rangle \\ |0\rangle &= \frac{-\Omega_{ef}}{\sqrt{\Omega_{gf}^2 + \Omega_{ef}^2}} |g\rangle + \frac{\Omega_{gf}}{\sqrt{\Omega_{gf}^2 + \Omega_{ef}^2}} |e\rangle \\ |+\rangle &= \frac{\Omega_{gf}}{\sqrt{2(\Omega_{gf}^2 + \Omega_{ef}^2)}} |g\rangle + \frac{\Omega_{ef}}{\sqrt{2(\Omega_{gf}^2 + \Omega_{ef}^2)}} |e\rangle + \frac{1}{\sqrt{2}} |f\rangle. \end{aligned}$$

Assume now that the Rabi frequencies depend on $s \in [0, \frac{3\pi}{2}]$ according to the following formula

$$\Omega_{gf}(s) = \begin{cases} \bar{\Omega}_g \cos^2 s, & \text{for } s \in [\frac{\pi}{2}, \frac{3\pi}{2}]; \\ 0, & \text{elsewhere.} \end{cases}, \quad \Omega_{ef}(s) = \begin{cases} \bar{\Omega}_e \sin^2 s, & \text{for } s \in [0, \pi]; \\ 0, & \text{elsewhere.} \end{cases}$$

with $\bar{\Omega}_g > 0$ and $\bar{\Omega}_e > 0$ constant parameter. With such s dependence, we have three analytic branches of the spectral decomposition:

- for $s \in]0, \frac{\pi}{2}[$ we have

$$\begin{aligned} \Omega_-(s) &= -\bar{\Omega}_e \sin s \text{ with } |-\rangle_s = \frac{|e\rangle - |f\rangle}{\sqrt{2}}. \\ \Omega_0 &= 0 \text{ with } |0\rangle_s = -|g\rangle \\ \Omega_+(s) &= \bar{\Omega}_e \sin s \text{ with } |+\rangle_s = \frac{|e\rangle + |f\rangle}{\sqrt{2}}. \end{aligned}$$

- for $s \in]\frac{\pi}{2}, \pi[$ we have

$$\begin{aligned}\Omega_-(s) &= -\sqrt{\bar{\Omega}_g^2 \cos^4 s + \bar{\Omega}_e^2 \sin^4 s} \text{ with } |-\rangle_s = \frac{\bar{\Omega}_g \cos^2 s |g\rangle + \bar{\Omega}_e \sin^2 s |e\rangle}{\sqrt{2(\bar{\Omega}_g^2 \cos^4 s + \bar{\Omega}_e^2 \sin^4 s)}} - \frac{1}{\sqrt{2}} |f\rangle \\ \Omega_0 &= 0 \text{ with } |0\rangle_s = \frac{-\bar{\Omega}_e \sin^2 s |g\rangle + \bar{\Omega}_g \cos^2 s |e\rangle}{\sqrt{\bar{\Omega}_g^2 \cos^4 s + \bar{\Omega}_e^2 \sin^4 s}} \\ \Omega_+(s) &= \sqrt{\bar{\Omega}_g^2 \cos^4 s + \bar{\Omega}_e^2 \sin^4 s} \text{ with } |+\rangle_s = \frac{\bar{\Omega}_g \cos^2 s |g\rangle + \bar{\Omega}_e \sin^2 s |e\rangle}{\sqrt{2(\bar{\Omega}_g^2 \cos^4 s + \bar{\Omega}_e^2 \sin^4 s)}} + \frac{1}{\sqrt{2}} |f\rangle.\end{aligned}$$

- for $s \in]\pi, \frac{3\pi}{2}[$ we have

$$\begin{aligned}\Omega_-(s) &= -\bar{\Omega}_g |\cos s| \text{ with } |-\rangle_s = \frac{|g\rangle - |f\rangle}{\sqrt{2}}. \\ \Omega_0 &= 0 \text{ with } |0\rangle_s = |e\rangle \\ \Omega_+(s) &= \bar{\Omega}_g |\cos s| \text{ with } |+\rangle_s = \frac{|g\rangle + |f\rangle}{\sqrt{2}}.\end{aligned}$$

Let us consider the eigenvalue Ω_0 : it is associated to the projector $\mathbf{P}_0(s)$ on $|0\rangle_s$ that depends smoothly on $s \in [0, \frac{3\pi}{2}]$ as shown by the concatenation of the above formula on the three intervals $]0, \frac{\pi}{2}[$, $]\frac{\pi}{2}, \pi[$ and $]\pi, \frac{3\pi}{2}[$. Thus assume that $|\psi\rangle_0 = |g\rangle$ then adiabatic Theorem 1 shows that, for $\epsilon > 0$ small enough, the solution of $i \frac{d}{dt} |\psi\rangle = \mathbf{H}_{\text{rwa}}^{1\text{st}} |\psi\rangle$ with the time-varying control amplitudes

$$[0, \frac{3\pi}{2\epsilon}] \ni t \mapsto (u_{fg}, u_{ef}) = \left(\frac{\Omega_{gf}(t)}{\mu_{gf}}, \frac{\Omega_{ef}(t)}{\mu_{ef}} \right)$$

is approximatively given by

$$|\psi\rangle_t \approx e^{i\theta_t} |0\rangle_{\epsilon t} = e^{i\theta_t} \begin{cases} -|g\rangle, & \text{for } t \in [0, \frac{\pi}{2\epsilon}]; \\ \frac{-\bar{\Omega}_e \sin^2(\epsilon t) |g\rangle + \bar{\Omega}_g \cos^2(\epsilon t) |e\rangle}{\sqrt{\bar{\Omega}_g^2 \cos^4(\epsilon t) + \bar{\Omega}_e^2 \sin^4(\epsilon t)}}, & \text{for } t \in [\frac{\pi}{2\epsilon}, \frac{\pi}{\epsilon}]; \\ |e\rangle, & \text{for } t \in [\frac{\pi}{\epsilon}, \frac{3\pi}{2\epsilon}]; \end{cases}$$

where θ_t is a time-varying global phase. Thus at the final time $t = \frac{3\pi}{2\epsilon}$, $|\psi\rangle$ coincides, up to a global phase to $|e\rangle$. It is surprising that during this adiabatic passage from $|g\rangle$ to $|e\rangle$ the control u_{ef} driving the transition $e \leftrightarrow f$ is turned on first whereas the control u_{gf} driving transition $g \leftrightarrow f$ is turned on later. It is also very interesting that the precise knowledge of the coupling parameter μ_{gf} and μ_{ef} is not necessary (robustness with respect to uncertainty in these parameters). However the precise knowledge of the transition frequencies ω_{gf} and ω_{ef} is required. Such adiabatic control strategies are widely used (see, e.g., the recent review article [39]).

Exercice 4. Design an adiabatic passage $s \mapsto (\Omega_{gf}(s), \Omega_{ef}(s))$ from $|g\rangle$ to $\frac{-|g\rangle + |e\rangle}{\sqrt{2}}$, up to a global phase.

2.2.4 Chirped pulse for a 2-level system

Let us start with $\mathbf{H} = \frac{\omega_{\text{eg}}}{2} \boldsymbol{\sigma}_z + \frac{u}{2} \boldsymbol{\sigma}_x$ considered in Subsection 2.1.4 and take the quasi-resonant control ($|\omega_r - \omega_{\text{eg}}| \ll \omega_{\text{eg}}$)

$$u(t) = v \left(e^{i(\omega_r t + \theta)} + e^{-i(\omega_r t + \theta)} \right)$$

where $v, \theta \in \mathbb{R}$, $|v|$ and $|\frac{d\theta}{dt}|$ are small and slowly varying

$$|v|, \left| \frac{d\theta}{dt} \right| \ll \omega_{\text{eg}}, \quad \left| \frac{dv}{dt} \right| \ll \omega_{\text{eg}} |v|, \quad \left| \frac{d^2\theta}{dt^2} \right| \ll \omega_{\text{eg}} \left| \frac{d\theta}{dt} \right|.$$

Following similar computations to those of Subsection 2.1.4, consider the following change of frame $|\psi\rangle = e^{-i\frac{\omega_r t + \theta}{2}\sigma_z} |\phi\rangle$. Then $i\frac{d}{dt}|\psi\rangle = \mathbf{H}|\psi\rangle$ becomes

$$i\frac{d}{dt}|\phi\rangle = \left(\frac{\omega_{\text{eg}} - \omega_r - \frac{d}{dt}\theta}{2}\sigma_z + \frac{ve^{2i(\omega_r t + \theta)} + v}{2}\sigma_+ + \frac{ve^{-2i(\omega_r t - \theta)} + v}{2}\sigma_- \right) |\phi\rangle.$$

With $\Delta_r = \omega_{\text{eg}} - \omega_r$ and $w = -\frac{d}{dt}\theta$ and using the first order rotating wave approximation (see (2.15) with $\mathbf{H}_{\text{rwa}}^{\text{1st}}$) we get the following averaged control Hamiltonian

$$\mathbf{H}_{\text{chirp}} = \frac{\Delta_r + w}{2}\sigma_z + \frac{v}{2}\sigma_x$$

where (v, w) are two real control inputs. Take three constant parameters $a > |\Delta_r|$, $b > 0$, $0 < \epsilon \ll a, b$. Set

$$w = a \cos(\epsilon t), \quad v = b \sin^2(\epsilon t).$$

Set $s = \epsilon t$ varying in $[0, \pi]$. These explicit expressions are not essential. Only the shape of $s \mapsto w(s)$ and of $s \mapsto v(s)$ are important here: w decreases regularly from a to $-a$; v is a bump function that remains strictly positive for $s \in]0, \pi[$ and that vanishes with its derivatives at $s = 0$ and $s = \pi$.

The spectral decomposition of $\mathbf{H}_{\text{chirp}}$ for $s \in]0, \pi[$ is standard with two distinct and opposite eigenvalues.

$$\begin{aligned} \Omega_- &= -\frac{\sqrt{(\Delta_r + w)^2 + v^2}}{2} \text{ associated to eigenstate } |-\rangle = \frac{\cos \alpha |g\rangle - (1 - \sin \alpha) |e\rangle}{\sqrt{2(1 - \sin \alpha)}} \\ \Omega_+ &= \frac{\sqrt{(\Delta_r + w)^2 + v^2}}{2} \text{ associated to eigenstate } |+\rangle = \frac{(1 - \sin \alpha) |g\rangle + \cos \alpha |e\rangle}{\sqrt{2(1 - \sin \alpha)}} \end{aligned}$$

where $\alpha \in]\frac{-\pi}{2}, \frac{\pi}{2}[$ is defined by $\tan \alpha = \frac{\Delta_r + w}{v}$. Since $\lim_{s \rightarrow 0^+} \alpha = \frac{\pi}{2}$ and $\lim_{s \rightarrow \pi^-} \alpha = -\frac{\pi}{2}$

$$\lim_{s \rightarrow 0^+} |-\rangle_s = |g\rangle, \quad \lim_{s \rightarrow 0^+} |+\rangle_s = |e\rangle, \quad \lim_{s \rightarrow \pi^-} |-\rangle_s = -|e\rangle, \quad \lim_{s \rightarrow \pi^-} |+\rangle_s = |g\rangle.$$

Consequently the adiabatic approximation of Theorem 1 implies that the solution $|\phi\rangle$ of

$$i\frac{d}{dt}|\phi\rangle = \left(\frac{\Delta_r + a \cos(\epsilon t)}{2}\sigma_z + \frac{b \sin^2(\epsilon t)}{2}\sigma_x \right) |\phi\rangle, \quad |\phi\rangle_{t=0} = |g\rangle$$

is given approximatively, for ϵ small and $t \in [0, \frac{\pi}{\epsilon}]$, by

$$|\phi\rangle_t = e^{i\vartheta_t} |-\rangle_{s=\epsilon t}$$

with ϑ_t a time-varying global phase. Thus for $t = \frac{\pi}{\epsilon}$, $|\phi\rangle$ coincides with $|e\rangle$ up to a global phase. Notice the remarkable robustness of such adiabatic control strategy. We do not need to know precisely neither the detuning Δ_r nor the chirp and control amplitudes a and b . This means in particular that such adiabatic chirp control from g to e is insensitive to all parameters appearing in a 2-level system.

This adiabatic chirp passage can be extended to any ladder configuration that is slightly an-harmonic.

2.3 Optimal control

Take the n -level system $i\frac{d}{dt}|\psi\rangle = (\mathbf{H}_0 + \sum_{k=1}^m u_k \mathbf{H}_k)|\psi\rangle$, initial and final states $|\psi_a\rangle$ and $|\psi_b\rangle$ and a transition time $T > 0$ ($\langle\psi_a|\psi_a\rangle = \langle\psi_b|\psi_b\rangle = 1$). We are looking for optimal controls $[0, T] \ni t \mapsto u(t)$ minimizing $\int_0^T (\sum_{k=1}^m u_k^2)$ and steering $|\psi\rangle$ from $|\psi_a\rangle$ at $t = 0$ to $|\psi_b\rangle$ at $t = T$ (assuming the system to be controllable, we consider only the cases where such a control exists). Thus we are considering the following problem

$$\begin{aligned} & \min_{u_k \in L^2([0, T], \mathbb{R}), k = 1, \dots, m} \frac{1}{2} \int_0^T \left(\sum_{k=1}^m u_k^2(t) \right) dt \quad (2.29) \\ & i\frac{d}{dt}|\psi\rangle = (\mathbf{H}_0 + \sum_{k=1}^m u_k \mathbf{H}_k)|\psi\rangle, t \in (0, T) \\ & |\psi\rangle_{t=0} = |\psi_a\rangle, |\langle\psi_b|\psi\rangle|_{t=T}^2 = 1 \end{aligned}$$

for given T , $|\psi_a\rangle$ and $|\psi_b\rangle$ ($\langle\psi_a|\psi_a\rangle = \langle\psi_b|\psi_b\rangle = 1$). Notice that $|\langle\psi_b|\psi\rangle|^2 = 1$ means that $|\psi\rangle_T = e^{i\theta}|\psi_b\rangle$ where $\theta \in \mathbb{R}$ is an arbitrary global phase.

Since the initial and final constraints are difficult to satisfy simultaneously from a numerical point of view, we will consider also the second problem where the final constraint is relaxed

$$\begin{aligned} & \min_{u_k \in L^2([0, T], \mathbb{R}), k = 1, \dots, m} \frac{1}{2} \int_0^T \left(\sum_{k=1}^m u_k^2(t) \right) dt + \frac{\alpha}{2} (1 - |\langle\psi_b|\psi\rangle|_T^2) \quad (2.30) \\ & i\frac{d}{dt}|\psi\rangle = (\mathbf{H}_0 + \sum_{k=1}^m u_k \mathbf{H}_k)|\psi\rangle, t \in (0, T) \\ & |\psi\rangle_{t=0} = |\psi_a\rangle \end{aligned}$$

with the positive penalization coefficient $\alpha > 0$. Notice that for α large this problem tends to the original one (2.29).

2.3.1 First order stationary condition

The first order conditions recalled in Appendix E yield to the following set of necessary conditions. Notice that the adjoint state can be seen as a Ket, denoted by $|p\rangle \in \mathbb{C}^n$ (of constant length but different of one in general) since it satisfies the same Schrödinger equation as $|\psi\rangle$.

For problem (2.29), the first order stationary conditions read:

$$\begin{cases} i\frac{d}{dt}|\psi\rangle = (\mathbf{H}_0 + \sum_{k=1}^m u_k \mathbf{H}_k)|\psi\rangle, t \in (0, T) \\ i\frac{d}{dt}|p\rangle = (\mathbf{H}_0 + \sum_{k=1}^m u_k \mathbf{H}_k)|p\rangle, t \in (0, T) \\ u_k = -\Im \left(\langle p | \mathbf{H}_k | \psi \rangle \right), k = 1, \dots, m, t \in (0, T) \\ |\psi\rangle_{t=0} = |\psi_a\rangle, |\langle\psi_b|\psi\rangle|_{t=T}^2 = 1 \end{cases} \quad (2.31)$$

For the relaxed problem (2.30), the first order stationary conditions read:

$$\begin{cases} i\frac{d}{dt}|\psi\rangle = (\mathbf{H}_0 + \sum_{k=1}^m u_k \mathbf{H}_k)|\psi\rangle, t \in (0, T) \\ i\frac{d}{dt}|p\rangle = (\mathbf{H}_0 + \sum_{k=1}^m u_k \mathbf{H}_k)|p\rangle, t \in (0, T) \\ u_k = -\Im \left(\langle p | \mathbf{H}_k | \psi \rangle \right), k = 1, \dots, m, t \in (0, T) \\ |\psi\rangle_{t=0} = |\psi_a\rangle, |p\rangle_{t=T} = -\alpha \langle\psi_b|\psi\rangle_{t=T} |\psi_b\rangle. \end{cases} \quad (2.32)$$

These optimality conditions differ only by the boundary conditions at $t = 0$ and $t = T$: the common part

$$\begin{aligned} i \frac{d}{dt} |\psi\rangle &= (\mathbf{H}_0 + \sum_{k=1}^m u_k \mathbf{H}_k) |\psi\rangle, \quad t \in (0, T) \\ i \frac{d}{dt} |p\rangle &= (\mathbf{H}_0 + \sum_{k=1}^m u_k \mathbf{H}_k) |p\rangle, \quad t \in (0, T) \\ u_k &= -\Im(\langle p | \mathbf{H}_k | \psi \rangle), \quad k = 1, \dots, m, \quad t \in (0, T) \end{aligned}$$

is a Hamiltonian system with $|\psi\rangle$ and $|p\rangle$ being the conjugate variables. The underlying Hamiltonian function is given by: $\bar{\mathbb{H}}(|\psi\rangle, |p\rangle) = \min_{u \in \mathbb{R}^m} \mathbb{H}(|\psi\rangle, |p\rangle, u)$ where

$$\mathbb{H}(|\psi\rangle, |p\rangle, u) = \frac{1}{2} \left(\sum_{k=1}^m u_k^2 \right) + \Im \left(\left\langle p \left| \mathbf{H}_0 + \sum_{k=1}^m u_k \mathbf{H}_k \right| \psi \right\rangle \right). \quad (2.33)$$

Thus for any solutions $(|\psi\rangle, |p\rangle, u)$ of (2.31) or (2.32), $\mathbb{H}(|\psi\rangle, |p\rangle, u)$ is independent of t . Notice that

$$\bar{\mathbb{H}}(|\psi\rangle, |p\rangle) = \Im(\langle p | \mathbf{H}_0 | \psi \rangle) - \frac{1}{2} \left(\sum_{k=1}^m \Im(\langle p | \mathbf{H}_k | \psi \rangle)^2 \right).$$

2.3.2 Monotone numerical scheme

For the relaxed problem (2.30) a general monotone iteration scheme exists. Defining the cost function

$$J(u) = \frac{1}{2} \int_0^T \left(\sum_{k=1}^m u_k^2(t) \right) dt + \frac{\alpha}{2} (1 - |\langle \psi_b | \psi_u \rangle|_T^2)$$

where $|\psi_u\rangle$ denotes the solution of $i \frac{d}{dt} |\psi\rangle = (\mathbf{H}_0 + \sum_{k=1}^m u_k \mathbf{H}_k) |\psi\rangle$ starting from $|\psi_a\rangle$, and starting from an initial guess $u^0 \in L^2([0, T], \mathbb{R}^m)$, this scheme generates a sequence of controls $u^\nu \in L^2([0, T], \mathbb{R}^m)$, $\nu = 1, 2, \dots$, such that the cost $J(u^\nu)$ is decreasing, $J(u^{\nu+1}) \leq J(u^\nu)$.

This scheme does not guaranty in general the convergence to an optimal solution. But applied on several examples, with a correct tuning of the penalization coefficient α , it produces interesting controls with $|\psi\rangle_T$ close to $|\psi_b\rangle$. Such monotonic schemes have been proposed for quantum systems in [61] (see also [73] for a slightly different version). We follow here the presentation of [12] which also provides an extension to infinite dimensional case. See also [19] for much earlier results on optimal control in infinite dimensional cases.

Take $u, v \in L^2([0, T], \mathbb{R}^m)$, denote by $\mathbf{P} = |\psi_b\rangle\langle\psi_b|$ the orthogonal projector on $|\psi_b\rangle$, then

$$J(u) - J(v) = - \frac{\alpha \left(\langle \psi_u - \psi_v | \mathbf{P} | \psi_u - \psi_v \rangle_T + \langle \psi_u - \psi_v | \mathbf{P} | \psi_v \rangle_T + \langle \psi_v | \mathbf{P} | \psi_u - \psi_v \rangle_T \right)}{2} + \int_0^T \frac{\sum_{k=1}^m (u_k - v_k)(u_k + v_k)}{2} dt.$$

Denote by $|p_v\rangle$ the adjoint associated to v , i.e. the solution of the backward systems

$$i \frac{d}{dt} |p_v\rangle = \left(\mathbf{H}_0 + \sum_{k=1}^m v_k \mathbf{H}_k \right) |p_v\rangle, \quad |p_v\rangle_T = -\alpha \mathbf{P} |\psi_v\rangle_T.$$

We have

$$i \frac{d}{dt} (|\psi_u\rangle - |\psi_v\rangle) = \left(\mathbf{H}_0 + \sum_{k=1}^m v_k \mathbf{H}_k \right) (|\psi_u\rangle - |\psi_v\rangle) + \left(\sum_{k=1}^m (u_k - v_k) \mathbf{H}_k \right) |\psi_u\rangle.$$

We consider the Hermitian product of this equation with the adjoint state $|p_v\rangle$:

$$\left\langle p_v \left| \frac{d(\psi_u - \psi_v)}{dt} \right. \right\rangle = \left\langle p_v \left| \frac{\mathbf{H}_0 + \sum_{k=1}^m v_k \mathbf{H}_k}{i} \right| \psi_u - \psi_v \right\rangle + \left\langle p_v \left| \frac{\sum_{k=1}^m (u_k - v_k) \mathbf{H}_k}{i} \right| \psi_u \right\rangle.$$

An integration by parts yields

$$\begin{aligned} \int_0^T \left\langle p_v \left| \frac{d(\psi_u - \psi_v)}{dt} \right. \right\rangle &= \langle p_v | \psi_u - \psi_v \rangle_T - \langle p_v | \psi_u - \psi_v \rangle_0 - \int_0^T \left\langle \frac{dp_v}{dt} \left| \psi_u - \psi_v \right. \right\rangle \\ &= -\alpha \langle \psi_v | \mathbf{P} | \psi_u - \psi_v \rangle_T + \int_0^T \left\langle p_v \left| \frac{\mathbf{H}_0 + \sum_{k=1}^m v_k \mathbf{H}_k}{i} \right| \psi_u - \psi_v \right\rangle \end{aligned}$$

since $|\psi_v\rangle_0 = |\psi_u\rangle_0$, $|p_v\rangle_T = -\alpha \mathbf{P} |\psi_v\rangle_T$ and $\frac{d}{dt} \langle p_v | = -\langle p_v | \left(\frac{\mathbf{H}_0 + \sum_{k=1}^m v_k \mathbf{H}_k}{i} \right)$. We get:

$$-\alpha \langle \psi_v | \mathbf{P} | \psi_u - \psi_v \rangle_T = \int_0^T \left\langle p_v \left| \frac{\sum_{k=1}^m (u_k - v_k) \mathbf{H}_k}{i} \right| \psi_u \right\rangle.$$

Thus $\alpha \Re(\langle \psi_v | \mathbf{P} | \psi_u - \psi_v \rangle_T) = -\int_0^T \Im(\langle p_v | \sum_{k=1}^m (u_k - v_k) \mathbf{H}_k | \psi_u \rangle)$. Finally we have

$$\begin{aligned} J(u) - J(v) &= -\frac{\alpha}{2} (\langle \psi_u - \psi_v | \mathbf{P} | \psi_u - \psi_v \rangle_T \\ &\quad + \frac{1}{2} \sum_{k=1}^m \left(\int_0^T (u_k - v_k) (u_k + v_k + 2\Im(\langle p_v | \mathbf{H}_k | \psi_u \rangle)) dt \right)). \end{aligned}$$

If each u_k satisfies $u_k = -\Im(\langle p_v | \mathbf{H}_k | \psi_u \rangle)$ for all $t \in [0, T)$ we have

$$J(u) - J(v) = -\frac{\alpha}{2} (\langle \psi_u - \psi_v | \mathbf{P} | \psi_u - \psi_v \rangle_T - \frac{1}{2} \sum_{k=1}^m \left(\int_0^T (u_k - v_k)^2 \right))$$

and thus $J(u) \leq J(v)$.

These computations suggest the following iteration scheme. Assume that, at step ν , we have computed the control u^ν , the associated quantum state $|\psi^\nu\rangle = |\psi_{u^\nu}\rangle$ and its adjoint $|p^\nu\rangle = |p_{u^\nu}\rangle$. We get their new time values $u^{\nu+1}$, $|\psi^{\nu+1}\rangle$ and $|p^{\nu+1}\rangle$ in two steps:

1. Imposing $u_k^{\nu+1} = -\Im(\langle p^\nu | \mathbf{H}_k | \psi^{\nu+1} \rangle)$ as a feedback, one get $u^{\nu+1}$ just by a forward integration of the nonlinear Schrödinger equation,

$$i \frac{d}{dt} |\psi\rangle = \left(\mathbf{H}_0 - \sum_{k=1}^m \Im(\langle p^\nu | \mathbf{H}_k | \psi \rangle) \mathbf{H}_k \right) |\psi\rangle, \quad |\psi\rangle_0 = |\psi_a\rangle,$$

that provides $[0, T] \ni t \mapsto |\psi^{\nu+1}\rangle$ and the m new controls $u_k^{\nu+1}$.

2. Backward integration from $t = T$ to $t = 0$ of

$$i \frac{d}{dt} |p\rangle = \left(\mathbf{H}_0 + \sum_{k=1}^m u_k^{\nu+1}(t) \mathbf{H}_k \right) |p\rangle, \quad |p\rangle_T = -\alpha \langle \psi_b | \psi^{\nu+1} \rangle_T | \psi_b \rangle$$

yields to the new adjoint trajectory $[0, T] \ni t \mapsto |p^{\nu+1}\rangle$.

Chapter 3

Quantum Measurement and discrete-time open systems

3.1 Quantum measurement

Whenever talking about the quantum state of a system, we refer to an observer's knowledge about a system. More precisely, it is the knowledge of the observer about the outcome of the future measurements on the system.

Such information theoretical definition of the state of a physical system may appear unfamiliar and uncomfortable as for instance, the observers with different knowledge may assign different states, simultaneously, to a single system. The most natural way to talk about the consistency of these assigned states is to define a *common state of maximal knowledge* as a common pure state. So far through these lecture notes, we have only considered such a *common state of maximal knowledge* and its evolution for a closed quantum system where no measurement is performed on the system. This pure state is well represented by a wave function $|\psi\rangle$ and its evolution is given by a Schrödinger equation as discussed through the previous chapters. The rest of these notes, however, is devoted to the study of the case where the quantum system is measured by an observer and in such a case, one needs to consider a wider formulation of the quantum state called the density operator (or density matrix in the case of finite dimensional quantum system). A density operator ρ is a Hermitian, semi-definite positive, trace-class operator defined on the Hilbert space of the quantum system. Moreover its trace is constant and equals unity during the evolution of the system. Such a density operator represents the knowledge of an observer about the quantum system.

Considering the collection $\{\rho_j\}$ of different density matrices assigned by different observers to a same physical system, the *common state of maximal knowledge* is a pure state defined by a wave function $|\psi\rangle$ such that there exists an $\epsilon > 0$ for which, $\rho_j - \epsilon|\psi\rangle\langle\psi|$ is a positive operator, i.e. ρ_j is the mixture of $|\psi\rangle$ with some other states. From a system theoretical point of view, we can think of this common state of maximal knowledge as the actual state of the system and the density matrix ρ_j is the filtering state encoding the information gained by an observer j .

Another consequence of such definition of the quantum state is that any measurement of the system, which leads to obtaining information on the system, necessarily changes the state of the system. This is known as the projection postulate. Through this section, we provide a brief overview of important measurement paradigms for quantum systems and the two next

sections are devoted to some concrete examples. This chapter is strongly inspired from [36] and [71].

3.1.1 Projective measurement

The projective measurement is the traditional description of measurement in quantum mechanics. Indeed, assume the measurement of a physical quantity O to which we can assign a Hermitian operator (observable) O defined on \mathcal{H} the Hilbert space of the system. We start by diagonalizing the operator as

$$O = \sum_{\nu} \lambda_{\nu} P_{\nu},$$

where λ_{ν} 's are the eigenvalues of O , which are all real and different, and P_{ν} the projection operator over the associated eigenspace. Note that, in general, the spectrum of the operator O can be degenerate and therefore the projection operator P_{ν} is not necessarily a rank-1 operator.

When we measure O , the result will be necessarily one of the eigenvalues λ_{ν} . Moreover, an outcome λ_{ν} of the measurement implies an instantaneous projection of the state of our knowledge through the associated projection operator. We also talk of the conditional state of the system as it is conditioned on the measurement outcome. Indeed, assuming that our state of knowledge at time t is given by the density matrix¹ ρ , measurement of the physical observable O at time t can be formulated as below:

1. The probability of obtaining the value λ_{ν} is given by $p_{\nu} = \text{Tr}(\rho P_{\nu})$; note that $\sum_{\nu} p_{\nu} = 1$ as $\sum_{\nu} P_{\nu} = I_{\mathcal{H}}$ ($I_{\mathcal{H}}$ represents the identity operator of \mathcal{H}).
2. After the measurement, the conditional (a posteriori) state of the system given the outcome λ_{ν} is

$$\rho_{+} = \frac{P_{\nu} \rho P_{\nu}}{p_{\nu}}.$$

Here, ρ_{+} denotes the state of the system just after the measurement. Furthermore, we have assumed that the evolution, from other causes, of the system during the measurement process is not significant and can be neglected.

A particular feature of the projective measurement is that, if the same measurement is immediately repeated, then the same result is guaranteed. Indeed, the probability of obtaining the same result λ_{ν} for the second measurement of the observable O is given by

$$\text{Tr}(P_{\nu} \rho_{+}) = \text{Tr}(P_{\nu} \rho P_{\nu}) / p_{\nu} = 1,$$

where we have applied the fact that $P_{\nu} P_{\nu} = P_{\nu}$.

For pure states (encoding the common state of maximal knowledge), $\rho = |\psi\rangle\langle\psi|$, the projective measurement can be more simply expressed as

$$p_{\nu} = \langle\psi|P_{\nu}|\psi\rangle,$$

$$\psi_{+} = \frac{P_{\nu}\psi}{\sqrt{p_{\nu}}}.$$

¹ ρ is a Hermitian, semi-definite positive, trace-class operator on \mathcal{H} of trace 1. Thus $\text{Tr}(\rho^2) \leq 1$ with equality only when ρ is an orthogonal projector on some pure quantum state $|\psi\rangle$, i.e., $\rho = |\psi\rangle\langle\psi|$.

Finally, the particular case of a projective measurement where the eigenvalues $\{\lambda_\nu\}$ are non-degenerate, and therefore the eigenprojections \mathbf{P}_ν are rank-1 operators, is called a *von Neumann measurement*.

3.1.2 Positive Operator Valued Measure (POVM)

The projective measurements are, generally, inadequate for describing real measurements, as the experimenter never directly measures the system of interest. In fact, the system of interest (for instance an atom or a quantized electromagnetic field) interacts with its environment (electromagnetic field or a probe atom), and the experimenter observes the effect of the system on the environment (the radiated field or the probe atom).

In order to formulate such measurement paradigm, we need to consider the quantum state in a larger Hilbert space consisting of the system and the measurement apparatus (also called the meter). Indeed, we consider a total initial state (before the measurement process) for the system together with the meter, which is given by a separable wavefunction

$$|\Psi\rangle = |\psi_S\rangle \otimes |\theta_M\rangle$$

living on the total Hilbert space $\mathcal{H}_S \otimes \mathcal{H}_M$. The measurement process consists in a unitary evolution of the whole state (leading to a non-separable–entangled– state) followed by a projective von Neumann measurement of the measurement apparatus. Let us denote by $U_{S,M}$ the unitary evolution entangling the state of the system to that of the meter, and by $\mathbf{O}_M = \mathbf{I}_S \otimes (\sum_\nu \lambda_\nu \mathbf{P}_\nu)$ the measured observable for the meter. Here, the projection operator \mathbf{P}_ν is a rank-1 projection in \mathcal{H}_M over the eigenstate $|\lambda_\nu\rangle \in \mathcal{H}_M$: $\mathbf{P}_\nu = |\lambda_\nu\rangle\langle\lambda_\nu|$. The measurement procedure can be formulated as below

1. The probability of obtaining the value λ_ν is given by $p_\nu = \langle\psi_S|\mathbf{M}_\nu^\dagger\mathbf{M}_\nu|\psi_S\rangle$ where \mathbf{M}_ν is an operator defined on \mathcal{H}_S , the Hilbert space of the system, by

$$(\mathbf{M}_\nu|\psi_S\rangle) \otimes |\lambda_\nu\rangle = (\mathbf{I}_S \otimes \mathbf{P}_\nu)U_{S,M}(|\psi_S\rangle \otimes |\theta_M\rangle).$$

Thus we have

$$U_{S,M}(|\psi_S\rangle \otimes |\theta_M\rangle) = \sum_\nu (\mathbf{M}_\nu|\psi_S\rangle) \otimes |\lambda_\nu\rangle.$$

Note that $\sum_\nu p_\nu = 1$ as

$$\sum_\nu \langle\psi_S|\mathbf{M}_\nu^\dagger\mathbf{M}_\nu|\psi_S\rangle = (|\psi_S\rangle \otimes |\theta_M\rangle)^\dagger \mathbf{U}_{S,M}^\dagger \left(\sum_\nu \mathbf{I}_H \otimes \mathbf{P}_\nu \right) \mathbf{U}_{S,M} (|\psi_S\rangle \otimes |\theta_M\rangle) = 1, \quad (3.1)$$

where we have used $\sum_\nu |\lambda_\nu\rangle\langle\lambda_\nu| = \mathbf{I}_M$ and $\mathbf{U}_{S,M}^\dagger \mathbf{U}_{S,M} = \mathbf{I}_{SM}$.

2. After the measurement, the conditional (a posteriori) state of the system given the outcome λ_ν is

$$|\psi_S\rangle_+ = \frac{\mathbf{M}_\nu|\psi_S\rangle}{\sqrt{p_\nu}}.$$

The operators \mathbf{M}_ν are called the *measurement operators* (see appendix C).

This can also be extended to the case of a mixed state where the probability of obtaining the value λ_ν is simply given by $p_\nu = \text{Tr}(\mathbf{M}_\nu \boldsymbol{\rho} \mathbf{M}_\nu^\dagger)$ and the conditional state given the outcome λ_ν is

$$\boldsymbol{\rho}_+ = \mathbb{M}_\nu(\boldsymbol{\rho}) := \frac{\mathbf{M}_\nu \boldsymbol{\rho} \mathbf{M}_\nu^\dagger}{\text{Tr}(\mathbf{M}_\nu \boldsymbol{\rho} \mathbf{M}_\nu^\dagger)}, \quad (3.2)$$

with \mathbb{M}_ν a nonlinear superoperator (it sends an operator to an operator) on \mathcal{H}_S . Indeed, through the computations of (3.1), $\sum_\nu \mathbf{M}_\nu^\dagger \mathbf{M}_\nu = \mathbf{I}_S$ and this, together with the positiveness of the operators $\mathbf{M}_\nu^\dagger \mathbf{M}_\nu$, are the only conditions for the set $\{\mathbf{M}_\nu\}$ to define a *Positive Operator Valued Measure* (POVM).

Also, one can define the *Generalized POVM* as the case where the initial state of the meter is not a pure state or that the projective measurement of the meter is not a von Neumann measurement (see [71, chapter 1] for a tutorial exposure of quantum measurement).

3.1.3 Quantum Non-Demolition (QND) measurement

Before anything, we need that the measurement of the meter observable \mathbf{O}_M after the interaction between the system and the meter encodes some information on the system S itself. This imposes some constraints on unitary transformation $\mathbf{U}_{S,M}$ considered in the previous subsection:

$$\mathbf{U}_{S,M}|\Psi\rangle = \mathbf{U}_{S,M}(|\psi_S\rangle \otimes |\theta_M\rangle).$$

Assume that such unitary transformation $\mathbf{U}_{S,M}$ results from a Hamiltonian $\mathbf{H} = \mathbf{H}_S + \mathbf{H}_M + \mathbf{H}_{SM}$ where \mathbf{H}_S and \mathbf{H}_M describe, respectively, the evolutions of the system and the meter and \mathbf{H}_{SM} denotes the system-meter interaction Hamiltonian. Then $\mathbf{U}_{S,M}$ is the propagator generated by \mathbf{H} during the interaction interval of length τ between S and M (for time-invariant \mathbf{H} , we have $\mathbf{U}_{S,M} = e^{-i\tau\mathbf{H}}$). It is clear that a necessary condition for the influence of S on \mathbf{O}_M just after the interaction is that $[\mathbf{H}, \mathbf{O}_M] \neq 0$. Otherwise $\mathbf{O}_M \mathbf{U}_{S,M} = \mathbf{U}_{S,M} \mathbf{O}_M$. Using the spectral decomposition $\mathbf{O}_M = \sum_\nu \lambda_\nu \mathbf{I}_S \otimes |\lambda_\nu\rangle$ (see previous subsection), we have for any ν ,

$$\mathbf{O}_M \mathbf{U}_{S,M}(|\psi_S\rangle \otimes |\lambda_\nu\rangle) = \mathbf{U}_{S,M} \mathbf{O}_M(|\psi_S\rangle \otimes |\lambda_\nu\rangle) = \lambda_\nu \mathbf{U}_{S,M}(|\psi_S\rangle \otimes |\theta_M\rangle).$$

Thus, necessarily $\mathbf{U}_{S,M}(|\psi_S\rangle \otimes |\lambda_\nu\rangle) = (\mathbf{U}_\nu |\psi_S\rangle) \otimes |\lambda_\nu\rangle$ where \mathbf{U}_ν is a unitary transformation on \mathcal{H}_S only. With $|\theta_M\rangle = \sum_\nu \theta_\nu |\lambda_\nu\rangle$, we get, for any $|\psi_S\rangle$,

$$\mathbf{U}_{S,M}(|\psi_S\rangle \otimes |\theta_M\rangle) = \sum_\nu \theta_\nu (\mathbf{U}_\nu |\psi_S\rangle) \otimes |\lambda_\nu\rangle$$

Then measurement operators \mathbf{M}_ν are equal to $\theta_\nu \mathbf{U}_\nu$. The probability to get measurement outcome ν , $\langle \psi_S | \mathbf{M}_\nu^\dagger \mathbf{M}_\nu | \psi_S \rangle = |\theta_\nu|^2$, is completely independent of systems state $|\psi_S\rangle$. This means that the measurement statistics for the meter observable \mathbf{O}_M does not encode any information on the system S and therefore $[\mathbf{H}, \mathbf{O}_M]$ must not vanish. When $\mathbf{H}_M = 0$, this necessary condition reads $[\mathbf{H}_{SM}, \mathbf{O}_M] \neq 0$.

Let us consider the measurement of a physical observable \mathbf{O}_S defined for the system S , through its coupling with a meter M with a von Neumann measurements of an observable \mathbf{O}_M on the meter. The essential condition for a measurement process of \mathbf{O}_S to be quantum non-demolition (abbreviated as QND) is that the measurement should not affect the eigenstates

of \mathbf{O}_S when \mathbf{O}_S admits a non degenerate spectrum (other-wise we have to consider the eigenspace instead of the eigenstate). A sufficient but not necessary condition for this is

$$[\mathbf{H}, \mathbf{O}_S] = 0$$

Under this condition \mathbf{O}_S and $\mathbf{U}_{S,M}$ commute. For eigenstate $|\mu\rangle$ of \mathbf{O}_S associated to eigenvalue μ , we have

$$\mathbf{O}_S \mathbf{U}_{S,M}(|\mu\rangle \otimes |\theta_M\rangle) = \mathbf{U}_{S,M} \mathbf{O}_S(|\mu\rangle \otimes |\theta_M\rangle) = \mu \mathbf{U}_{S,M}(|\mu\rangle \otimes |\theta_M\rangle).$$

Exercise 5. *Prove that the above formula implies $\mathbf{U}_{S,M}(|\mu\rangle \otimes |\theta_M\rangle) = |\mu\rangle \otimes (\mathbf{U}_\mu |\theta_M\rangle)$ where \mathbf{U}_μ is a unitary operator on \mathcal{H}_M only: $\mathbf{U}_{S,M}$ does not entangle eigenstates of \mathbf{O}_S with the meter.*

With the measurement operators \mathbf{M}_ν , we also have

$$\mathbf{U}_{S,M}(|\mu\rangle \otimes |\theta_M\rangle) = \sum_{\nu} \mathbf{M}_\nu |\mu\rangle \otimes |\lambda_\nu\rangle.$$

Thus necessarily, using exercise 5 each $\mathbf{M}_\nu |\mu\rangle$ is colinear to $|\mu\rangle$. Whatever the measurement outcome ν is, the conditional state provided by (3.2) remains unchanged: $\rho_+ = \mathbb{M}_\nu(\rho)$ when $\rho = |\mu\rangle\langle\mu|$. When the spectrum of \mathbf{O}_S is degenerate and \mathbf{P}_μ is the projector on the eigenspace associated to the eigenvalue μ of \mathbf{O}_S , this invariance reads: for all ν , $\mathbf{M}_\nu \mathbf{P}_\mu = \mathbf{P}_\mu \mathbf{M}_\nu$. Any eigenspace of \mathbf{O}_S is invariant with respect to all the \mathbf{M}_ν 's.

3.1.4 Stochastic process attached to a POVM

To any POVM defined by a set of measurement operators (\mathbf{M}_ν) on \mathcal{H}_S , is attached a stochastic process. This process admits the set $\{\rho\}$ of density operators on \mathcal{H}_S as state space. It is defined by the transition rules:

$$\rho_+ = \frac{\mathbf{M}_\nu \rho \mathbf{M}_\nu^\dagger}{\text{Tr}(\mathbf{M}_\nu \rho \mathbf{M}_\nu^\dagger)} \text{ with probability } p_\nu = \text{Tr}(\mathbf{M}_\nu \rho \mathbf{M}_\nu^\dagger). \quad (3.3)$$

For any observable \mathbf{A} on \mathcal{H}_S , its conditional expectation value after the transition knowing the state ρ just before the transition is given by

$$\mathbb{E}(\text{Tr}(\mathbf{A} \rho_+) / \rho) = \text{Tr}(\mathbf{A} \mathbb{K}(\rho)) \quad (3.4)$$

where the linear map $\mathbb{K}(\rho) = \sum_{\nu} \mathbf{M}_\nu \rho \mathbf{M}_\nu^\dagger$ is a Kraus map (see appendix C).

Assume that this POVM provides a QND measurement of an observable \mathbf{O}_S on \mathcal{H}_S . Then the orthogonal projector $\mathbf{P}_{\mathbf{O}_S}$ on any eigenspace of \mathbf{O}_S , yields to a martingale² $\text{Tr}(\rho \mathbf{P}_{\mathbf{O}_S})$:

$$\mathbb{E}(\text{Tr}(\mathbf{P}_{\mathbf{O}_S} \rho_+) / \rho) = \text{Tr}(\mathbf{P}_{\mathbf{O}_S} \rho)$$

since $\mathbf{P}_{\mathbf{O}_S}$ is a stationary point of the dual Kraus map \mathbb{K}^* : $\mathbb{K}^*(\mathbf{P}_{\mathbf{O}_S}) = \sum_{\nu} \mathbf{M}_\nu^\dagger \mathbf{P}_{\mathbf{O}_S} \mathbf{M}_\nu = \mathbf{P}_{\mathbf{O}_S}$. Moreover, if $\mathbf{P}_{\mathbf{O}_S}$ is of rank one, then it corresponds to a stationary state $\bar{\rho} = \mathbf{P}_{\mathbf{O}_S}$ of the Markov process (3.3): for all ν , $\mathbf{M}_\nu \bar{\rho} \mathbf{M}_\nu^\dagger = \text{Tr}(\mathbf{M}_\nu \bar{\rho} \mathbf{M}_\nu^\dagger) \bar{\rho}$.

Exercise 6. *Prove that for a QND measurement of a system observable \mathbf{O}_S , the random process $\text{Tr}(\rho \mathbf{O}_S)$ is also a martingale.*

²See appendix F.

3.2 Example of the photon-box

This section is devoted to the case study of a photon box consisting of a cavity quantum electrodynamics setup developed within Laboratoire Kastler-Brossel (LKB) at École Normale Supérieure.

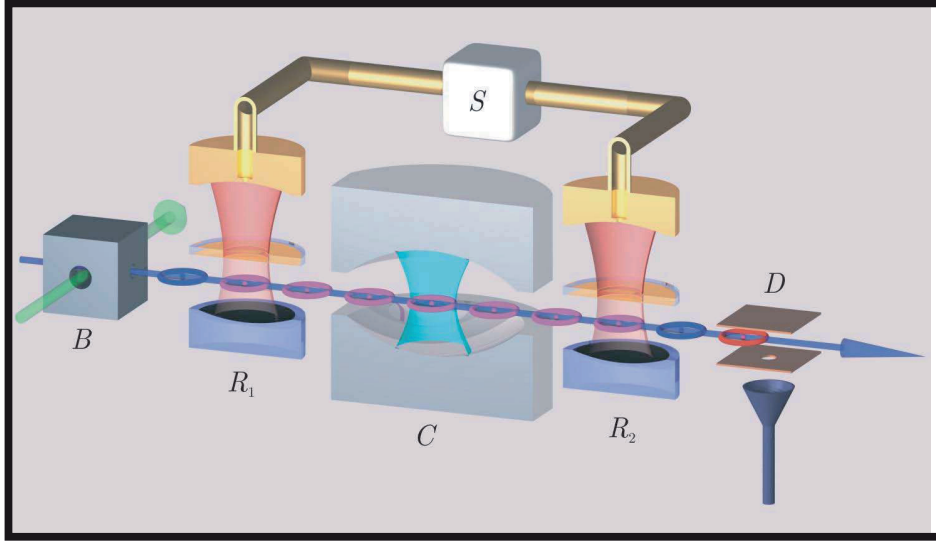

Figure 3.1: The LKB photon box; atoms get out box B one by one, undergo then a first Rabi pulse in Ramsey zone R_1 , become entangled with electromagnetic field trapped in C , undergo a second Rabi pulse in Ramsey zone R_2 and finally are measured in the detector D .

3.2.1 Markov chain model

Here S corresponds to a quantized trapped mode inside the cavity. It is described by a wave function $|\psi\rangle$ in the Hilbert space \mathcal{H}_S (see section 1.1)

$$\mathcal{H}_S = \left\{ \sum_{n=0}^{\infty} \psi_n |n\rangle \mid (\psi_n)_{n=0}^{\infty} \in l^2(\mathbb{C}) \right\},$$

where $|n\rangle$ represents the Fock state associated to exactly n photons inside the cavity and $l^2(\mathbb{C})$ is the space of square summable sequences in \mathbb{C} ($\sum_{n=0}^{\infty} |\psi_n|^2 = 1$). The meter M is associated to atoms : $\mathcal{H}_M = \mathbb{C}^2$, each atom admits two energy levels and is described by a wave function $c_g|g\rangle + c_e|e\rangle$ with $|c_g|^2 + |c_e|^2 = 1$.

Let us follow an atom leaving B where it is prepared in state $|g\rangle$. It is symbolized by a small horizontal and blue torus in Figure 3.1. When atom comes out B , the state of the composite system atom/field is separable and is denoted by $|\Psi\rangle_B \in \mathcal{H}_M \otimes \mathcal{H}_S$

$$|\Psi\rangle_B = |g\rangle \otimes |\psi\rangle. \quad (3.5)$$

When atom comes out the first Ramsey zone R_1 (pink torus between R_1 and C), the state remains separable but has changed to

$$|\Psi\rangle_{R_1} = (\mathbf{U}_{R_1} \otimes \mathbf{I})|\Psi\rangle_B = (\mathbf{U}_{R_1}|g\rangle) \otimes |\psi\rangle \quad (3.6)$$

where the unitary transformation performed in R_1 only affects the atom:

$$\mathbf{U}_{R_1} = e^{-i\frac{\theta_1}{2}(x_1\boldsymbol{\sigma}_x + y_1\boldsymbol{\sigma}_y + z_1\boldsymbol{\sigma}_z)} = \cos(\frac{\theta_1}{2}) - i\sin(\frac{\theta_1}{2})(x_1\boldsymbol{\sigma}_x + y_1\boldsymbol{\sigma}_y + z_1\boldsymbol{\sigma}_z) \quad (3.7)$$

corresponds, in the Bloch sphere representation, to a rotation of angle θ_1 around the oriented axis defined by the unit-length vector $x_1\vec{i} + y_1\vec{j} + z_1\vec{k}$ ($x_1^2 + y_1^2 + z_1^2 = 1$), see section 1.2.2.

When atom leaves the cavity C , the state is not anymore separable: atom and field become entangled and the state is described by

$$|\Psi\rangle_C = \mathbf{U}_C|\Psi\rangle_{R_1} \quad (3.8)$$

where the unitary transformation \mathbf{U}_C on $\mathcal{H}_M \otimes \mathcal{H}_S$ is associated to a Jaynes-Cummings Hamiltonian for describing the atom/field interaction:

$$\mathbf{H}_C = \frac{\Delta}{2}\boldsymbol{\sigma}_z + i\frac{\Omega}{2}(\boldsymbol{\sigma}_-\mathbf{a}^\dagger - \boldsymbol{\sigma}_+\mathbf{a}) \quad (3.9)$$

is the Jaynes-Cumming Hamiltonian after the rotating wave approximation ($\Delta = \omega_{eg} - \omega_c$ de-tuning between atom and cavity field, Ω the vacuum Rabi pulsation, see section 2.1.6 and (2.23) with $v = 0$, $\omega_r = \omega_c$ and $\Delta_c = 0$ and $\Delta_{eg} = \Delta$). The precise form of \mathbf{U}_C is given in next subsection for resonant and dispersive cases.

When the atom leaves the second Ramsey zone R_2 , the state becomes

$$|\Psi\rangle_{R_2} = (\mathbf{U}_{R_2} \otimes \mathbf{I})|\Psi\rangle_C$$

where \mathbf{U}_{R_2} is similar to \mathbf{U}_{R_1} but with different parameters θ_2, x_2, y_2, z_2 ,

$$\mathbf{U}_{R_2} = e^{-i\frac{\theta_2}{2}(x_2\boldsymbol{\sigma}_x + y_2\boldsymbol{\sigma}_y + z_2\boldsymbol{\sigma}_z)} = \cos(\frac{\theta_2}{2}) - i\sin(\frac{\theta_2}{2})(x_2\boldsymbol{\sigma}_x + y_2\boldsymbol{\sigma}_y + z_2\boldsymbol{\sigma}_z). \quad (3.10)$$

This means that, just before the measurement in D , the state is given by

$$|\Psi\rangle_{R_2} = \mathbf{U}|g\rangle \otimes |\psi\rangle = |g\rangle \otimes \mathbf{M}_g|\psi\rangle + |e\rangle \otimes \mathbf{M}_e|\psi\rangle \quad (3.11)$$

where $\mathbf{U} = \mathbf{U}_{R_2}\mathbf{U}_C\mathbf{U}_{R_1}$ is the total unitary transformation defining the linear measurement operators \mathbf{M}_g and \mathbf{M}_e on \mathcal{H}_S .

Denote by $s \in \{g, e\}$ the measurement outcome in detector D : with probability $p_s = \langle\psi|\mathbf{M}_s^\dagger\mathbf{M}_s|\psi\rangle$ we get s . Just after the measurement outcome s , the state becomes separable. It has partially collapsed to

$$|\Psi\rangle_D = \frac{1}{\sqrt{p_s}} |s\rangle \otimes (\mathbf{M}_s|\psi\rangle) = \frac{|s\rangle \otimes (\mathbf{M}_s|\psi\rangle)}{\sqrt{\langle\psi|\mathbf{M}_s^\dagger\mathbf{M}_s|\psi\rangle}}.$$

We have a Markov process: after the complete passage of an atom, the cavity state initially equal to $|\psi\rangle$ undergoes an irreversible and stochastic jump to $|\psi\rangle_+$ driven by \mathbf{M}_g and \mathbf{M}_e defined via unitary operator $\mathbf{U} = \mathbf{U}_{R_2}\mathbf{U}_C\mathbf{U}_{R_1}$ and (3.11):

$$|\psi\rangle_+ = \begin{cases} \frac{\mathbf{M}_g|\psi\rangle}{\sqrt{\langle\psi|\mathbf{M}_g^\dagger\mathbf{M}_g|\psi\rangle}}, & \text{with probability } p_g = \langle\psi|\mathbf{M}_g^\dagger\mathbf{M}_g|\psi\rangle; \\ \frac{\mathbf{M}_e|\psi\rangle}{\sqrt{\langle\psi|\mathbf{M}_e^\dagger\mathbf{M}_e|\psi\rangle}}, & \text{with probability } p_e = \langle\psi|\mathbf{M}_e^\dagger\mathbf{M}_e|\psi\rangle. \end{cases} \quad (3.12)$$

For the density matrix formulation we have thus

$$\rho_+ = \begin{cases} \mathbb{M}_g(\rho) = \frac{M_g \rho M_g^\dagger}{\text{Tr}(M_g \rho M_g^\dagger)}, & \text{with probability } p_g = \text{Tr}(M_g \rho M_g^\dagger); \\ \mathbb{M}_e(\rho) = \frac{M_e \rho M_e^\dagger}{\text{Tr}(M_e \rho M_e^\dagger)}, & \text{with probability } p_e = \text{Tr}(M_e \rho M_e^\dagger). \end{cases} \quad (3.13)$$

Exercise 7. Consider M_g and M_e defined by (3.11). Show that, for any density matrix ρ the operator (defining a Kraus map, see appendix C)

$$M_g \rho M_g^\dagger + M_e \rho M_e^\dagger$$

does not depend on $(\theta_2, x_2, y_2, z_2)$, the parameters of the second Ramsey pulse U_{R_2} .

3.2.2 Jaynes-Cummings propagator

In the resonant case, $\Delta = 0$. The atom/cavity propagator U_C based on Jaynes-Cummings Hamiltonian (3.9) admits the following form (see [36] for the detailed derivations including Gaussian radial dependence of the quantized mode and atom velocity):

$$U_C = |g\rangle\langle g| \cos\left(\frac{\Theta}{2}\sqrt{N}\right) + |e\rangle\langle e| \cos\left(\frac{\Theta}{2}\sqrt{N+I}\right) + |g\rangle\langle e| \left(\frac{\sin\left(\frac{\Theta}{2}\sqrt{N}\right)}{\sqrt{N}}\right) \mathbf{a}^\dagger - |e\rangle\langle g| \mathbf{a} \left(\frac{\sin\left(\frac{\Theta}{2}\sqrt{N}\right)}{\sqrt{N}}\right) \quad (3.14)$$

where $N = \mathbf{a}^\dagger \mathbf{a}$ is the photon number operator, the adjustable parameter Θ being the Rabi angle with zero photon.

In the dispersive case, $|\Delta| \gg |\Omega|$, U_C based on Jaynes-Cummings Hamiltonian (3.9) admits the following form (see [36] for the detailed derivations based on adiabatic invariance):

$$U_C = |g\rangle\langle g| e^{-i\phi(N)} + |e\rangle\langle e| e^{i\phi(N+I)} \quad (3.15)$$

where the dephasing $\phi(N)$ depends on the photon number and can be approximated by a linear real function: $\phi(N) = \vartheta_0 + \vartheta N$, the phases ϑ_0 and ϑ being adjustable parameters.

The exercise below can be seen as a simplified derivation of the above formulae for U_C .

Exercise 8. Let us assume that the Jaynes-Cummings propagator U_C admits the following form

$$U_C = e^{-i\tau \left(\frac{\Delta(|e\rangle\langle e| - |g\rangle\langle g|)}{2} + i \frac{\Omega(|g\rangle\langle e| \mathbf{a}^\dagger - |e\rangle\langle g| \mathbf{a})}{2} \right)}$$

where τ is an interaction time.

1. Show by recurrence on integer k that

$$\begin{aligned} \left(\Delta(|e\rangle\langle e| - |g\rangle\langle g|) + i\Omega(|g\rangle\langle e| \mathbf{a}^\dagger - |e\rangle\langle g| \mathbf{a}) \right)^{2k} = \\ |e\rangle\langle e| (\Delta^2 + (N+1)\Omega^2)^k + |g\rangle\langle g| (\Delta^2 + N\Omega^2)^k \end{aligned}$$

and that

$$\begin{aligned} & \left(\Delta(|e\rangle\langle e| - |g\rangle\langle g|) + i\Omega(|g\rangle\langle e|\mathbf{a}^\dagger - |e\rangle\langle g|\mathbf{a}) \right)^{2k+1} = \\ & |e\rangle\langle e|\Delta(\Delta^2 + (\mathbf{N} + 1)\Omega^2)^k - |g\rangle\langle g|\Delta(\Delta^2 + \mathbf{N}\Omega^2)^k \\ & + i\Omega(|g\rangle\langle e|(\Delta^2 + \mathbf{N}\Omega^2)^k \mathbf{a}^\dagger - |e\rangle\langle g|\mathbf{a}(\Delta^2 + \mathbf{N}\Omega^2)^k). \end{aligned}$$

2. Deduce that

$$\begin{aligned} \mathbf{U}_C = & |g\rangle\langle g| \left(\cos\left(\frac{\tau\sqrt{\Delta^2 + \mathbf{N}\Omega^2}}{2}\right) + i\frac{\Delta \sin\left(\frac{\tau\sqrt{\Delta^2 + \mathbf{N}\Omega^2}}{2}\right)}{\sqrt{\Delta^2 + \mathbf{N}\Omega^2}} \right) \\ & + |e\rangle\langle e| \left(\cos\left(\frac{\tau\sqrt{\Delta^2 + (\mathbf{N} + 1)\Omega^2}}{2}\right) - i\frac{\Delta \sin\left(\frac{\tau\sqrt{\Delta^2 + (\mathbf{N} + 1)\Omega^2}}{2}\right)}{\sqrt{\Delta^2 + (\mathbf{N} + 1)\Omega^2}} \right) \\ & + |g\rangle\langle e| \left(\frac{\Omega \sin\left(\frac{\tau\sqrt{\Delta^2 + \mathbf{N}\Omega^2}}{2}\right)}{\sqrt{\Delta^2 + \mathbf{N}\Omega^2}} \right) \mathbf{a}^\dagger - |e\rangle\langle g|\mathbf{a} \left(\frac{\Omega \sin\left(\frac{\tau\sqrt{\Delta^2 + \mathbf{N}\Omega^2}}{2}\right)}{\sqrt{\Delta^2 + \mathbf{N}\Omega^2}} \right). \quad (3.16) \end{aligned}$$

3. In the resonant case, $\Delta = 0$, express the vacuum Rabi angle Θ appearing in (3.14) with respect to Ω and τ .

4. In the dispersive case, $|\Delta| \gg |\Omega|$, and when the interaction time τ is large, $\Delta\tau \sim \left(\frac{\Delta}{\Omega}\right)^2$, show that, up to first order terms in Ω/Δ , we get

$$\begin{aligned} e^{-i\tau\left(\frac{\Delta(|e\rangle\langle e| - |g\rangle\langle g|)}{2} + i\frac{\Omega(|g\rangle\langle e|\mathbf{a}^\dagger - |e\rangle\langle g|\mathbf{a})}{2}\right)} = & |g\rangle\langle g|e^{i\left(\frac{\Delta\tau}{2} + \frac{\Omega^2\tau}{4\Delta}\mathbf{N}\right)} \\ & + |e\rangle\langle e|e^{-i\left(\frac{\Delta\tau}{2} + \frac{\Omega^2\tau}{4\Delta}(\mathbf{N} + 1)\right)}. \end{aligned}$$

Express the phases ϑ_0 and ϑ appearing in (3.15) with respect to τ , Δ and Ω .

3.2.3 Resonant case

Let us detail the operators \mathbf{M}_g and \mathbf{M}_e defined in (3.11) when \mathbf{U}_C is given by (3.14), $\mathbf{U}_{R_1} = e^{-i\frac{\theta_1}{2}\sigma_y}$ and $\mathbf{U}_{R_2} = \mathbf{I}$. Since $\mathbf{U}_{R_1} = \cos\left(\frac{\theta_1}{2}\right) + \sin\left(\frac{\theta_1}{2}\right)(|g\rangle\langle e| - |e\rangle\langle g|)$, $|\Psi\rangle_{R_1}$ given by (3.6) reads:

$$|\Psi\rangle_{R_1} = \left(\cos\left(\frac{\theta_1}{2}\right)|g\rangle - \sin\left(\frac{\theta_1}{2}\right)|e\rangle \right) \otimes |\psi\rangle.$$

Then $|\Psi\rangle_C$ given by (3.8) becomes

$$\begin{aligned} |\Psi\rangle_C &= \cos\left(\frac{\theta_1}{2}\right) \left(|g\rangle \otimes \cos\left(\frac{\Theta}{2}\sqrt{N}\right) |\psi\rangle - |e\rangle \otimes \mathbf{a} \left(\frac{\sin\left(\frac{\Theta}{2}\sqrt{N}\right)}{\sqrt{N}} \right) |\psi\rangle \right) \\ &\quad - \sin\left(\frac{\theta_1}{2}\right) \left(|e\rangle \otimes \cos\left(\frac{\Theta}{2}\sqrt{N+1}\right) |\psi\rangle + |g\rangle \otimes \left(\frac{\sin\left(\frac{\Theta}{2}\sqrt{N}\right)}{\sqrt{N}} \right) \mathbf{a}^\dagger |\psi\rangle \right) \\ &= |g\rangle \otimes \left(\cos\left(\frac{\theta_1}{2}\right) \cos\left(\frac{\Theta}{2}\sqrt{N}\right) - \sin\left(\frac{\theta_1}{2}\right) \left(\frac{\sin\left(\frac{\Theta}{2}\sqrt{N}\right)}{\sqrt{N}} \right) \mathbf{a}^\dagger \right) |\psi\rangle \\ &\quad - |e\rangle \otimes \left(\sin\left(\frac{\theta_1}{2}\right) \cos\left(\frac{\Theta}{2}\sqrt{N+1}\right) + \cos\left(\frac{\theta_1}{2}\right) \mathbf{a} \left(\frac{\sin\left(\frac{\Theta}{2}\sqrt{N}\right)}{\sqrt{N}} \right) \right) |\psi\rangle. \end{aligned}$$

Since $U_{R_2} = \mathbf{I}$, $|\Psi\rangle_C = |\Psi\rangle_{R_2}$. The measurement operators are thus given by

$$\begin{aligned} M_g &= \cos\left(\frac{\theta_1}{2}\right) \cos\left(\frac{\Theta}{2}\sqrt{N}\right) - \sin\left(\frac{\theta_1}{2}\right) \left(\frac{\sin\left(\frac{\Theta}{2}\sqrt{N}\right)}{\sqrt{N}} \right) \mathbf{a}^\dagger \\ M_e &= -\sin\left(\frac{\theta_1}{2}\right) \cos\left(\frac{\Theta}{2}\sqrt{N+1}\right) - \cos\left(\frac{\theta_1}{2}\right) \mathbf{a} \left(\frac{\sin\left(\frac{\Theta}{2}\sqrt{N}\right)}{\sqrt{N}} \right) \end{aligned} \quad (3.17)$$

Exercise 9. Verify that the operators (measurement operators) given by (3.17) satisfy $M_g^\dagger M_g + M_e^\dagger M_e = \mathbf{I}$ (hint: use, $N = \mathbf{a}^\dagger \mathbf{a}$, $\mathbf{a} f(N) = f(N+1) \mathbf{a}$ and $\mathbf{a}^\dagger f(N) = f(N-1) \mathbf{a}^\dagger$).

3.2.4 Dispersive case

Let us now describe the measurement operators M_g and M_e defined in (3.11) when U_C is given by (3.15), $U_{R_1} = e^{-i\frac{\pi}{4}\sigma_y}$ and $U_{R_2} = e^{-i\frac{\pi}{4}(-\sin\eta\sigma_x + \cos\eta\sigma_y)}$ (with angle η chosen below). Since $U_{R_1} = \frac{|g\rangle\langle e| - |e\rangle\langle g|}{\sqrt{2}}$, $|\Psi\rangle_{R_1}$ given by (3.6) reads:

$$|\Psi\rangle_{R_1} = \frac{|g\rangle - |e\rangle}{\sqrt{2}} \otimes |\psi\rangle.$$

Then $|\Psi\rangle_C$ given by (3.8) becomes

$$|\Psi\rangle_C = \frac{1}{\sqrt{2}} |g\rangle \otimes e^{-i\phi(N)} |\psi\rangle - \frac{1}{\sqrt{2}} |e\rangle \otimes e^{i\phi(N+1)} |\psi\rangle.$$

Since $U_{R_2} = \frac{1}{\sqrt{2}} (\mathbf{I} + e^{i\eta}|g\rangle\langle e| - e^{-i\eta}|e\rangle\langle g|)$, we have

$$\begin{aligned} 2|\Psi\rangle_{R_2} &= (|g\rangle - e^{-i\eta}|e\rangle) \otimes e^{-i\phi(N)} |\psi\rangle - (e^{i\eta}|g\rangle + |e\rangle) \otimes e^{i\phi(N+1)} |\psi\rangle \\ &= |g\rangle \otimes \left(e^{-i\phi(N)} - e^{i(\eta+\phi(N+1))} \right) |\psi\rangle - |e\rangle \otimes \left(e^{-i(\eta+\phi(N))} + e^{i\phi(N+1)} \right) |\psi\rangle \end{aligned}$$

where $\phi(N) = \vartheta_0 + N\vartheta$. Take φ_0 an arbitrary phase and set $\eta = 2(\varphi_0 - \vartheta_0) - \vartheta - \pi$. Then the measurement operators are given by the simple formulae

$$M_g = \cos(\varphi_0 + N\vartheta), \quad M_e = \sin(\varphi_0 + N\vartheta) \quad (3.18)$$

where we have removed the irrelevant global phase factors $e^{i(\varphi_0 - \vartheta_0)}$ for M_g and $e^{i(\vartheta_0 - \varphi_0 + \pi/2)}$ for M_e . In the Fock basis $\{|n\rangle\}_0^\infty$, the operator M_g (resp. M_e) is diagonal with diagonal elements $\cos(n\vartheta + \varphi_0)$ (resp. $\sin(n\vartheta + \varphi_0)$). We note in particular that $M_g^\dagger M_g + M_e^\dagger M_e = \mathbf{I}$.

Exercice 10. Take \mathbf{M}_g and \mathbf{M}_e defined by (3.11) with \mathbf{U}_C given by (3.15) with ϕ an arbitrary real value function.

1. Show that any Fock state $|n\rangle$ is an eigenvector of \mathbf{M}_g and \mathbf{M}_e , whatever \mathbf{U}_{R_1} and \mathbf{U}_{R_2} are.
2. Deduce from preceding question that, for any density operator ρ , any integer n and any Ramsey pulses \mathbf{U}_{R_1} and \mathbf{U}_{R_2} , we have

$$\langle n | \mathbf{M}_g \rho \mathbf{M}_g^\dagger | n \rangle + \langle n | \mathbf{M}_e \rho \mathbf{M}_e^\dagger | n \rangle = \langle n | \rho | n \rangle.$$

3. What does-it mean for the Markov chain associated to such \mathbf{M}_g and \mathbf{M}_e and defined by (3.13).

3.2.5 QND measurements: open-loop asymptotic behavior

Through this subsection, we consider the measurement associated to the dispersive coupling regime between the system (cavity) and the meter (atoms). As discussed through the previous subsection, the measurement operators \mathbf{M}_g and \mathbf{M}_e are given by (3.18). These operators being diagonal in the basis $\{|n\rangle\}_{n=0}^\infty$ of photon number states, they commute with the physical observable $\mathbf{N} = \mathbf{a}^\dagger \mathbf{a}$ (photon number operator). Indeed, following the definition of Subsection 3.1.3, they define a quantum non-demolition (QND) measurement of the photon number observable \mathbf{N} . Here, we study the asymptotic behavior of the Markov chain associated to a repetitive application of such QND measurements. The cavity state after the k 'th measurement is represented by ρ_k and follows the Markov chain dynamics

$$\rho_{k+1} = \mathbb{M}_{s_k}(\rho_k),$$

where s_k takes the value g (resp. e) with probability $p_{g,k} = \text{Tr}(\mathbf{M}_g \rho_k \mathbf{M}_g^\dagger)$ (resp. with probability $p_{e,k} = \text{Tr}(\mathbf{M}_e \rho_k \mathbf{M}_e^\dagger)$). We have the following theorem:

Theorem 2. Consider the Markov process defined above with an initial density matrix ρ_0 defined on the subspace $\text{span}\{|n\rangle \mid n = 0, 1, \dots, n^{\max}\}$. Also, assume the non-degeneracy assumption

$$\cos^2(\varphi_m) \neq \cos^2(\varphi_n) \quad \forall n \neq m \in \{0, 1, \dots, n^{\max}\},$$

where $\varphi_n = \varphi_0 + n\vartheta$. Then

- for any $n \in \{0, \dots, n^{\max}\}$, $\text{Tr}(\rho_k |n\rangle\langle n|) = \langle n | \rho_k | n \rangle$ is a martingale
- ρ_k converges with probability 1 to one of the $n^{\max} + 1$ Fock state $|n\rangle\langle n|$ with $n \in \{0, \dots, n^{\max}\}$.
- the probability to converge towards the Fock state $|n\rangle\langle n|$ is given by $\text{Tr}(\rho_0 |n\rangle\langle n|) = \langle n | \rho_0 | n \rangle$.

Proof. First, we note that, the measurement operators \mathbf{M}_g and \mathbf{M}_e being diagonal in the basis of photon number states, and ρ_0 being defined on the subspace $\text{span}\{|n\rangle \mid n = 0, 1, \dots, n^{\max}\}$, the state ρ_k remains in this subspace for all $k \geq 0$. We can therefore restrict the proof to this finite dimensional Hilbert space.

Let us prove that $\text{Tr}(\rho_k |n\rangle\langle n|)$ is a martingale. Set $\xi = |n\rangle\langle n|$. We have

$$\begin{aligned} \mathbb{E}(\text{Tr}(\xi \rho_{k+1}) \mid \rho_k) &= p_{g,k} \text{Tr}\left(\xi \frac{M_g \rho_k M_g^\dagger}{p_{g,k}}\right) + p_{e,k} \text{Tr}\left(\xi \frac{M_e \rho_k M_e^\dagger}{p_{e,k}}\right) \\ &= \text{Tr}\left(\xi M_g \rho_k M_g^\dagger\right) + \text{Tr}\left(\xi M_e \rho_k M_e^\dagger\right) = \text{Tr}\left(\rho_k (M_g^\dagger \xi M_g + M_e^\dagger \xi M_e)\right). \end{aligned}$$

Since ξ commutes with M_g and M_e and $M_g^\dagger M_g + M_e^\dagger M_e = \mathbf{I}$, we have $\mathbb{E}(\text{Tr}(\xi \rho_{k+1}) \mid \rho_k) = \text{Tr}(\xi \rho_k)$. This implies that $\text{Tr}(\rho_k |n\rangle\langle n|)$ is a martingale.

Now, we consider the Lyapunov function

$$V(\rho) = \sum_{n=0}^{n^{\max}} f(\text{Tr}(|n\rangle\langle n| \rho)), \quad (3.19)$$

where $f(x) = x^2/2$. The function f being convex and each $\text{Tr}(|n\rangle\langle n| \rho)$ being a martingale, we infer that $V(\rho)$ is a sub-martingale:

$$\mathbb{E}(V(\rho_{k+1}) \mid \rho_k) \geq V(\rho_k).$$

Indeed, we have

$$\begin{aligned} \mathbb{E}(V(\rho_{k+1}) \mid \rho_k) &= \sum_{n=0}^{n^{\max}} \sum_{\mu=g,e} \text{Tr}\left(M_\mu \rho_k M_\mu^\dagger\right) f\left(\frac{\text{Tr}(|n\rangle\langle n| M_\mu \rho_k M_\mu^\dagger)}{\text{Tr}(M_\mu \rho_k M_\mu^\dagger)}\right) \\ &= V(\rho_k) + \frac{1}{2} \sum_{n=0}^{n^{\max}} \text{Tr}\left(M_g \rho_k M_g^\dagger\right) \text{Tr}\left(M_e \rho_k M_e^\dagger\right) \left(\frac{|\cos(\varphi_n)|^2 \langle n | \rho_k | n \rangle}{\text{Tr}(M_g \rho_k M_g^\dagger)} - \frac{|\sin(\varphi_n)|^2 \langle n | \rho_k | n \rangle}{\text{Tr}(M_e \rho_k M_e^\dagger)}\right)^2. \end{aligned}$$

Here, we have used the fact that

$$\langle n | \mathbb{M}_g(\rho_k) | n \rangle = \frac{|\cos(\varphi_n)|^2 \langle n | \rho_k | n \rangle}{\text{Tr}(M_g \rho_k M_g^\dagger)}, \quad \text{and} \quad \langle n | \mathbb{M}_e(\rho_k) | n \rangle = \frac{|\sin(\varphi_n)|^2 \langle n | \rho_k | n \rangle}{\text{Tr}(M_e \rho_k M_e^\dagger)}.$$

Thus, $V(\rho_k)$ is a sub-martingale, and in addition we have a precise bound on the difference $\mathbb{E}(V(\rho_{k+1}) \mid \rho_k) - V(\rho_k)$. Furthermore, it is easy to see that the function

$$W(\rho) = \frac{1}{2} \sum_{n=0}^{n^{\max}} \text{Tr}\left(M_g \rho M_g^\dagger\right) \text{Tr}\left(M_e \rho M_e^\dagger\right) \left(\frac{|\cos(\varphi_n)|^2 \langle n | \rho | n \rangle}{\text{Tr}(M_g \rho M_g^\dagger)} - \frac{|\sin(\varphi_n)|^2 \langle n | \rho | n \rangle}{\text{Tr}(M_e \rho M_e^\dagger)}\right)^2$$

is a continuous function of ρ . Now, we apply the Theorem 7 of Appendix F. The ω -limit set K (in the sense of almost sure convergence), for the trajectories ρ_k , is a subset of the set $\{\rho \mid W(\rho) = 0\}$. Let us consider a density matrix ρ_∞ in this ω -limit set. Therefore $W(\rho_\infty) = 0$ implies

$$\frac{|\cos(\varphi_n)|^2 \langle n | \rho_\infty | n \rangle}{\text{Tr}(M_g \rho_\infty M_g^\dagger)} = \frac{|\sin(\varphi_n)|^2 \langle n | \rho_\infty | n \rangle}{\text{Tr}(M_e \rho_\infty M_e^\dagger)}, \quad \forall n = 0, 1, \dots, n^{\max}. \quad (3.20)$$

Since $\text{Tr}(\rho_\infty) = 1$, there is at least one \bar{n} such that $\langle \bar{n} | \rho_\infty | \bar{n} \rangle > 0$. Then the above equation leads to

$$\text{Tr}\left(M_g \rho_\infty M_g^\dagger\right) |\sin(\varphi_{\bar{n}})|^2 = \text{Tr}\left(M_e \rho_\infty M_e^\dagger\right) |\cos(\varphi_{\bar{n}})|^2,$$

and therefore

$$\mathrm{Tr} \left(\mathbf{M}_g \boldsymbol{\rho}_\infty \mathbf{M}_g^\dagger \right) = \left(\mathrm{Tr} \left(\mathbf{M}_g \boldsymbol{\rho}_\infty \mathbf{M}_g^\dagger \right) + \mathrm{Tr} \left(\mathbf{M}_e \boldsymbol{\rho}_\infty \mathbf{M}_e^\dagger \right) \right) |\cos(\varphi_{\bar{n}})|^2.$$

Noting that $\mathbf{M}_g^\dagger \mathbf{M}_g + \mathbf{M}_e^\dagger \mathbf{M}_e = \mathbf{I}$, we have

$$\mathrm{Tr} \left(\mathbf{M}_g \boldsymbol{\rho}_\infty \mathbf{M}_g^\dagger \right) = |\cos(\varphi_{\bar{n}})|^2 \quad \text{and} \quad \mathrm{Tr} \left(\mathbf{M}_e \boldsymbol{\rho}_\infty \mathbf{M}_e^\dagger \right) = |\sin(\varphi_{\bar{n}})|^2.$$

Assume now that there exists \bar{n}_1 and \bar{n}_2 such that $\langle \bar{n}_1 | \boldsymbol{\rho}_\infty | \bar{n}_1 \rangle > 0$ and $\langle \bar{n}_2 | \boldsymbol{\rho}_\infty | \bar{n}_2 \rangle > 0$. Then, the above equation implies that

$$\cos^2(\varphi_{\bar{n}_1}) = \cos^2(\varphi_{\bar{n}_2}),$$

which is in contradiction with the non-degeneracy assumption of the theorem. This closes the proof of the second assertion, and the ω -limit set is reduced to the set of fixed points $|n\rangle\langle n|$, with $n \in \{0, 1, \dots, n^{\max}\}$.

We have shown that the probability measure associated to the random variable $\boldsymbol{\rho}_k$ converges to $\sum_{n=0}^{n^{\max}} p_n \delta_{|n\rangle\langle n|}$, where $\delta_{|n\rangle\langle n|}$ denotes the Dirac measure at $|n\rangle\langle n|$ and p_n is the probability of convergence towards $|n\rangle\langle n|$. In particular, we have $\mathbb{E}(\mathrm{Tr}(\boldsymbol{\rho}_k |n\rangle\langle n|)) \rightarrow p_n$. But $\mathrm{Tr}(\boldsymbol{\rho}_k |n\rangle\langle n|)$ is a martingale, thus $\mathbb{E}(\mathrm{Tr}(\boldsymbol{\rho}_k |n\rangle\langle n|)) = \mathbb{E}(\mathrm{Tr}(\boldsymbol{\rho}_0 |0\rangle\langle 0|))$ and consequently $p_n = \langle n | \boldsymbol{\rho}_0 | n \rangle$. \square

3.2.6 QND measurements and quantum-state feedback

The Theorem 2 implies that the QND measurement of the Subsection 3.2.4 can be seen as a photon-number state preparation tool. However, this state preparation is non-deterministic as we can not be sure to converge towards a desired Fock state $|\bar{n}\rangle\langle \bar{n}|$. One way of removing this indeterminism is to repeat the QND measurement process by re-preparing the same initial state and re-launching the same measurement process up to reaching $|\bar{n}\rangle\langle \bar{n}|$. However this can be very time-consuming and perhaps inefficient when dealing with the measurement uncertainties and relaxations (to be studied later through these notes).

This non-deterministic preparation tool can be turned into a deterministic stabilization protocol with the addition of an appropriate feedback strategy [56]. Indeed, one can consider that after the passage of each atom a control pulse is injected in the cavity (see Figure 3.2.6). This could be modeled through the following Markov chain:

$$\boldsymbol{\rho}_{k+\frac{1}{2}} = \mathbb{M}_{s_k}(\boldsymbol{\rho}_k), \quad \boldsymbol{\rho}_{k+1} = \mathbb{D}_{\alpha_k}(\boldsymbol{\rho}_{k+\frac{1}{2}}),$$

where $\mathbb{D}_\alpha(\boldsymbol{\rho}) = \mathbf{D}_\alpha \boldsymbol{\rho} \mathbf{D}_\alpha$, with the displacement operator (see Section 1.1.3) $\mathbf{D}_\alpha = \exp(\alpha \mathbf{a}^\dagger - \alpha^* \mathbf{a})$. Here, α_k is a complex control amplitude denoting the amplitude and phase of the applied pulse. The idea is to construct a Lyapunov function $\bar{V}(\boldsymbol{\rho})$ similar to (3.19) but with a different weighting on various photon-number states to favor the convergence towards a particular Fock state with \bar{n} photon (set-point),

$$\bar{V}(\boldsymbol{\rho}) = V(\boldsymbol{\rho}) + \sum_{n \geq 0} f(n) \mathrm{Tr}(\boldsymbol{\rho} |n\rangle\langle n|),$$

with $\mathbb{N} \ni n \mapsto f(n)$ being a real function, maximum at $n = \bar{n}$, strictly increasing (resp. decreasing) for $n \in \{0, \dots, \bar{n}\}$ (resp. $n \in \{\bar{n}, \dots, +\infty\}$).

The control input will then be selected so that the function $\bar{V}(\rho_k)$ becomes a submartingale. This means that at each time-step k , the value α_k is the argument of the maximum of the conditional expectation of $\bar{V}(\rho_{k+1})$ knowing the density operator at step k , ρ_k , and the control input at step k , $\alpha_k = \alpha$ with $|\alpha| \leq \bar{\alpha}$ ($\bar{\alpha} > 0$ being a fixed upper-bound):

$$\alpha_k := \operatorname{argmax}_{|\alpha| \leq \bar{\alpha}} \left\{ \mathbb{E} \left(\bar{V}(\rho_{k+1}) | \rho_k, \alpha_k = \alpha \right) \right\}$$

where

$$\mathbb{E} \left(\bar{V}(\rho_{k+1}) | \rho_k, \alpha_k = \alpha \right) = \operatorname{Tr} \left(\mathbf{M}_g \rho_k \mathbf{M}_g \right) \bar{V} \left(\mathbb{D}_\alpha \left(\mathbb{M}_g \left(\rho_k \right) \right) \right) + \operatorname{Tr} \left(\mathbf{M}_e \rho_k \mathbf{M}_e \right) \bar{V} \left(\mathbb{D}_\alpha \left(\mathbb{M}_e \left(\rho_k \right) \right) \right).$$

Thus α_k is a function of ρ_k , the quantum-state at step k . This kind of feedback law is called a *measurement-based feedback* since the controller is a classical controller based on the past measurement outcomes summarized in the present quantum state ρ_k . Note furthermore that one needs to take care of the fact that the system lives on an infinite dimensional Hilbert space. We refer to [60, 5] for more details on such a feedback strategy.

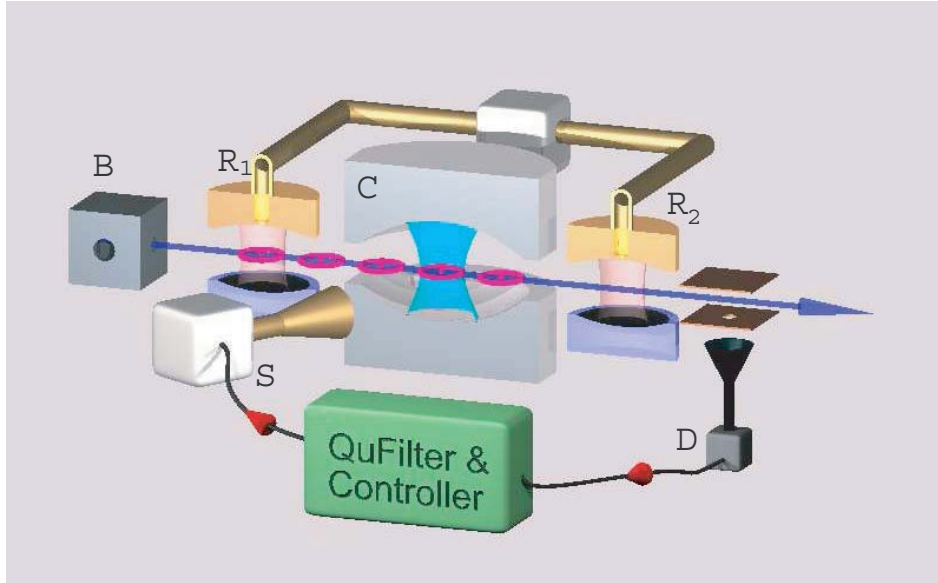

Figure 3.2: A schematic of the closed-loop system borrowed from [30]: an appropriate coherent pulse with a controlled amplitude and phase is injected between two atom passages.

Exercise 11 (Open-loop convergence in the resonant case). Consider the Markov chain $\rho_{k+1} = \mathbb{M}_{s_k}(\rho_k)$ where $s_k = g$ (resp. $s_k = e$) with probability $p_{g,k} = \operatorname{Tr}(\mathbf{M}_g \rho_k \mathbf{M}_g^\dagger)$ (resp. $p_{e,k} = \operatorname{Tr}(\mathbf{M}_e \rho_k \mathbf{M}_e^\dagger)$). The Kraus operator are given by (3.17) with $\theta_1 = 0$. Assume the initial state to be defined on the subspace $\{|n\rangle\}_{n=0}^{n_{\max}}$ and that the cavity state at step k is described by the density operator ρ_k .

1. Show that

$$\mathbb{E} \left(\operatorname{Tr} \left(\mathbf{N} \rho_{k+1} \right) \mid \rho_k \right) = \operatorname{Tr} \left(\mathbf{N} \rho_k \right) - \operatorname{Tr} \left(\sin^2 \left(\frac{\Theta}{2} \sqrt{\mathbf{N}} \right) \rho_k \right).$$

2. Assume that for any integer n , $\Theta\sqrt{n}/\pi$ is irrational. Then prove, using Theorem 7 of Appendix F, that almost surely ρ_k tends to the vacuum state $|0\rangle\langle 0|$ whatever its initial condition is.
3. When $\Theta\sqrt{n}/\pi$ is rational for some integer n , describes the possible ω -limit sets for ρ_k .

3.2.7 Measurement uncertainties and Bayesian quantum filtering

This subsection is directly inspired from [30, 59]. Let us consider now the situation where the atom passes through the cavity but we do not detect it after the second Ramsey zone. To describe the cavity state we have to use mixed states and thus density matrix ρ and the operator M_g and M_e defined in (3.2). Having no knowledge on whether the atom ends up in the state $|g\rangle$ or $|e\rangle$, the best we can say about the cavity state (our knowledge of the system) after the passage of the atom is its expectation value:

$$\rho_+ = p_g M_g(\rho) + p_e M_e(\rho) = M_g \rho M_g^\dagger + M_e \rho M_e^\dagger. \quad (3.21)$$

The above map, sending ρ to ρ_+ , defines the Kraus representation for a linear quantum operation (see Appendix C for a definition and properties of linear quantum operations).

Now consider the case where we realize the atom detection but we are uncertain about its result. Indeed, in practice, the detection process is not perfect and we need to take into account at least three kinds of uncertainties:

- the atom preparation process is itself a random process following a Poisson law; indeed the samples carrying the atoms that pass through the setup might be empty of atoms; we note the occupancy rate of the pulses by $\eta_a \in]0, 1[$ (η_a is about 0.4 for the LKB experimental setup);
- the atom detector is imperfect and can miss a certain percentage of the atoms; we denote the detector's efficiency by $\eta_d \in]0, 1[$ (η_d is about 0.8 for the LKB experimental setup);
- the atom detector is not fault-free and the result of the measurement (atom in the state $|g\rangle$ or $|e\rangle$) can be interchanged; we denote the fault rate by $\eta_f \in [0, 1/2)$ (η_f is about 0.1 for the LKB experimental setup).

Whenever realizing the atom detection, we can achieve three results: 1- the atom is in $|g\rangle$, 2- the atom in $|e\rangle$, 3-the detector does not detect any atom. For each situation we may have various possibilities:

Atom in $|g\rangle$: Either the atom is actually in the state $|e\rangle$ and the detector has made a mistake by detecting it in $|g\rangle$ (this happens with a probability p_g^f to be determined) or the atom is really in the state $|g\rangle$ (this happens with probability $1 - p_g^f$). Indeed, the conditional probability of having the atom in $|e\rangle$ while the detection result has been $|g\rangle$ may be computed through the Bayesian formula and is given by:

$$p_g^f = \frac{\eta_f p_e}{\eta_f p_e + (1 - \eta_f) p_g},$$

where $p_g = \text{Tr}(M_g \rho M_g^\dagger)$ and $p_e = \text{Tr}(M_e \rho M_e^\dagger)$.

Also, the conditional evolution of the density matrix (as our knowledge on the cavity state conditioned on the measurement result) is given as follows:

$$\begin{aligned}\rho_+ &= p_g^f \mathbb{M}_e(\rho) + (1 - p_g^f) \mathbb{M}_g(\rho) \\ &= \frac{\eta_f}{\eta_f p_e + (1 - \eta_f) p_g} \mathbf{M}_e \rho \mathbf{M}_e^\dagger + \frac{1 - \eta_f}{\eta_f p_e + (1 - \eta_f) p_g} \mathbf{M}_g \rho \mathbf{M}_g^\dagger \\ &= \frac{\eta_f \mathbf{M}_e \rho \mathbf{M}_e^\dagger + (1 - \eta_f) \mathbf{M}_g \rho \mathbf{M}_g^\dagger}{\text{Tr}(\eta_f \mathbf{M}_e \rho \mathbf{M}_e^\dagger + (1 - \eta_f) \mathbf{M}_g \rho \mathbf{M}_g^\dagger)}.\end{aligned}$$

Atom in $|e\rangle$: Exactly in the same way, the conditional evolution of the density matrix is given as follows:

$$\begin{aligned}\rho_+ &= \frac{\eta_f}{\eta_f p_g + (1 - \eta_f) p_e} \mathbf{M}_g \rho \mathbf{M}_g^\dagger + \frac{1 - \eta_f}{\eta_f p_g + (1 - \eta_f) p_e} \mathbf{M}_e \rho \mathbf{M}_e^\dagger \\ &= \frac{\eta_f \mathbf{M}_g \rho \mathbf{M}_g^\dagger + (1 - \eta_f) \mathbf{M}_e \rho \mathbf{M}_e^\dagger}{\text{Tr}(\eta_f \mathbf{M}_g \rho \mathbf{M}_g^\dagger + (1 - \eta_f) \mathbf{M}_e \rho \mathbf{M}_e^\dagger)}.\end{aligned}$$

No atom detected: Either the pulse has been empty (this happens with a probability p_{na} to be determined) or there has been an atom which has not been detected by the detector (this happens with the probability $1 - p_{\text{na}}$). Indeed, the conditional probability of having an empty pulse while no atom has been detected by the detector can be computed through the Bayes rule and is given by:

$$p_{\text{na}} = \frac{1 - \eta_a}{\eta_a(1 - \eta_d) + (1 - \eta_a)} = \frac{1 - \eta_a}{1 - \eta_a \eta_d}.$$

In such case the density matrix remains untouched. The complementary situation corresponding to an undetected atom leads to an evolution of the density matrix through the Kraus map (3.21). Finally, the conditional evolution of the density matrix (conditioned on the result of the measurement indicating no detected atoms) is given as follows:

$$\begin{aligned}\rho_+ &= p_{\text{na}} \rho + (1 - p_{\text{na}}) (\mathbf{M}_g \rho \mathbf{M}_g^\dagger + \mathbf{M}_e \rho \mathbf{M}_e^\dagger) \\ &= \frac{1 - \eta_a}{1 - \eta_a \eta_d} \rho + \frac{\eta_a(1 - \eta_d)}{1 - \eta_a \eta_d} (\mathbf{M}_g \rho \mathbf{M}_g^\dagger + \mathbf{M}_e \rho \mathbf{M}_e^\dagger) \\ &= \frac{(1 - \eta_a) \rho + \eta_a(1 - \eta_d) (\mathbf{M}_g \rho \mathbf{M}_g^\dagger + \mathbf{M}_e \rho \mathbf{M}_e^\dagger)}{\text{Tr}((1 - \eta_a) \rho + \eta_a(1 - \eta_d) (\mathbf{M}_g \rho \mathbf{M}_g^\dagger + \mathbf{M}_e \rho \mathbf{M}_e^\dagger))}\end{aligned}$$

Here, still, we have a Kraus representation for a linear quantum operation.

With the following quantum operations:

$$\begin{aligned}\mathbb{K}_g(\rho) &= \eta_a \eta_d (\eta_f \mathbf{M}_e \rho \mathbf{M}_e^\dagger + (1 - \eta_f) \mathbf{M}_g \rho \mathbf{M}_g^\dagger) \\ \mathbb{K}_e(\rho) &= \eta_a \eta_d (\eta_f \mathbf{M}_g \rho \mathbf{M}_g^\dagger + (1 - \eta_f) \mathbf{M}_e \rho \mathbf{M}_e^\dagger) \\ \mathbb{K}_o(\rho) &= (1 - \eta_a) \rho + \eta_a(1 - \eta_d) (\mathbf{M}_g \rho \mathbf{M}_g^\dagger + \mathbf{M}_e \rho \mathbf{M}_e^\dagger)\end{aligned}$$

the above computations define the following Markov describing the imperfect measurement process with three possible outcomes, one detection in g , one detection in e and zero detection:

$$\rho_+ = \begin{cases} \frac{\mathbb{K}_g(\rho)}{\text{Tr}(\mathbb{K}_g(\rho))}, & \text{with probability } p_g = \text{Tr}(\mathbb{K}_g(\rho)); \\ \frac{\mathbb{K}_e(\rho)}{\text{Tr}(\mathbb{K}_e(\rho))}, & \text{with probability } p_e = \text{Tr}(\mathbb{K}_e(\rho)); \\ \frac{\mathbb{K}_o(\rho)}{\text{Tr}(\mathbb{K}_o(\rho))}, & \text{with probability } p_o = \text{Tr}(\mathbb{K}_o(\rho)). \end{cases} \quad (3.22)$$

Notice that, since $\mathbb{K}_g(\rho) + \mathbb{K}_e(\rho) + \mathbb{K}_o(\rho) = (1 - \eta_a)\rho + \eta_a(\mathbf{M}_g\rho\mathbf{M}_g^\dagger + \mathbf{M}_e\rho\mathbf{M}_e^\dagger)$ and $\mathbf{M}_g^\dagger\mathbf{M}_g + \mathbf{M}_e^\dagger\mathbf{M}_e = \mathbf{I}$, we have $p_g + p_e + p_o = 1$.

These transition rules provide simple update rules of ρ_{k+1} depending on ρ_k and the detection outcomes at step k belonging to $\{g, e, o\}$. The resulting quantum state ρ_k depends thus on the initial state ρ_0 and the measurement outcomes between 0 and $k-1$. In other words, The quantum state obeys to a filtering process of state ρ with the measurement outcomes as input, a so called *quantum filter*.

3.2.8 Relaxation as an unread measurement

Additionally to the above uncertainties in the measurement process, one needs to consider the relaxation of the system due to its coupling to the environment to obtain a complete model for the open system. Two main sources of relaxation can be considered here. A first source concerns the photon loss phenomenon caused by their absorption by the environment (the mirrors in particular). The second source concerns the photon gain phenomenon due to the coupling of the field with a reservoir of non-zero temperature ($T \approx 0.8K$). Denoting by κ_- and by κ_+ , respectively the photon loss and the photon gain rate, and assuming that the environment is in thermal equilibrium at temperature T , we have (k_b denoting the Boltzmann constant and ω_c the cavity's resonance frequency),

$$\kappa_+ = \kappa_- e^{-\frac{\hbar\omega_c}{k_b T}}.$$

We refer to [36, Chapter 4, Page 187] for more details. By defining n_{th} as the average number of thermal photons per mode at frequency ω_c , given by Planck's law:

$$n_{\text{th}} = \frac{1}{e^{\frac{\hbar\omega_c}{k_b T}} - 1},$$

we can express both κ_- and κ_+ in term of unique cavity rate κ :

$$\kappa_- = \kappa(1 + n_{\text{th}}), \quad \kappa_+ = \kappa n_{\text{th}}.$$

Note that, here the dominant phenomenon is the photon loss as we work in low temperature regime and therefore $n_{\text{th}} \ll 1$ ($n_{\text{th}} \approx 0.05$ for the LKB experiment). We start therefore by investigating the relaxation caused by the photon loss, which can be modeled through a measurement operator \mathbf{M}_{loss} , proportional to the photon annihilation operator \mathbf{a} . Indeed, considering τ_a the duration of a pulse (time interval between the passage of the two atoms), this measurement operator \mathbf{M}_{loss} can be written as $\sqrt{\kappa_- \tau_a} \mathbf{a}$ so that the probability of losing a photon during the current pulse is given by (we neglect the possibility of losing many photons at a same pulse as it admits a very small probability)

$$P_{\text{loss}} = \text{Tr} \left(\mathbf{M}_{\text{loss}}^\dagger \mathbf{M}_{\text{loss}} \rho \right) = \kappa_- \tau_a \text{Tr} \left(\mathbf{a}^\dagger \mathbf{a} \rho \right) = \kappa_- \tau_a \text{Tr} (\mathbf{N} \rho).$$

This natural expression indicates that the probability of the photon loss is proportional to the duration of the pulse and to the mean number of photons in the cavity. Here, we assume moreover that the pulse duration is much smaller than the cavity decay time $T_{\text{cav}} = 1/\kappa$ ($\tau_a \ll T_{\text{cav}}$). For the LKB experimental setup, the pulse duration τ_a is about $85e - 06$ seconds and T_{cav} is about $13e - 02$ seconds and therefore this assumption is clearly satisfied.

Let us assume now that we dispose of an instrument allowing us to detect this photon loss when it happens. As soon as we detect a photon loss, the cavity density matrix ρ evolves drastically as follows:

$$\rho_+ = \frac{M_{\text{loss}}\rho M_{\text{loss}}^\dagger}{\text{Tr}(M_{\text{loss}}\rho M_{\text{loss}}^\dagger)} = \frac{\mathbf{a}\rho\mathbf{a}^\dagger}{\text{Tr}(\mathbf{N}\rho)},$$

recalling that this loss happens with a small probability of $\text{Tr}(\mathbf{N}\rho)(1+n_{\text{th}})\tau_a/\tau_{\text{cav}}$. Now, let us consider the situation where we do not detect any photon loss. A first impression would be that the density matrix should not change. This is not correct and the fact that we do not detect any photon, actually, updates our information on the system as it privileges the probability of having a fewer number of photons in the cavity. In order to have a more clear idea of the situation, let us assume that, similarly to the photon loss case, we associate a measurement operator $M_{\text{no-loss}}$ to the phenomenon of not detecting a photon loss. Let us now find this jump operator.

In order to have a well-defined POVM measurement, we need to have

$$M_{\text{loss}}^\dagger M_{\text{loss}} + M_{\text{no-loss}}^\dagger M_{\text{no-loss}} = \mathbf{I}. \quad (3.23)$$

This, in particular, forbids the possibility of having $M_{\text{no-loss}} = \mathbf{I}$. Indeed, a possible solution, up to the first order in τ_a/T_{cav} , is given by:

$$M_{\text{no-loss}} = \mathbf{I} - (1+n_{\text{th}})\tau_a \frac{\tau_a}{2T_{\text{cav}}} \mathbf{a}^\dagger \mathbf{a}.$$

Noting now that, we actually do not dispose of a measurement instrument indicating the loss of the photons, the evolution of the density matrix is given by the following Kraus representation:

$$\rho_+ = M_{\text{loss}}\rho M_{\text{loss}}^\dagger + M_{\text{no-loss}}\rho M_{\text{no-loss}}^\dagger = \rho + (1+n_{\text{th}})\frac{\tau_a}{T_{\text{cav}}} \left(\mathbf{a}\rho\mathbf{a}^\dagger - \frac{1}{2}\mathbf{a}^\dagger\mathbf{a}\rho - \frac{1}{2}\rho\mathbf{a}^\dagger\mathbf{a} \right),$$

where we have still neglected the second order terms in τ_a/T_{cav} .

The photon gain phenomenon can be treated exactly in the same way and through the measurement operator $M_{\text{gain}} = \sqrt{\kappa+\tau_a}\mathbf{a}^\dagger$ proportional to the photon creation operator. The total evolution can be therefore written as follows:

$$\rho_+ = M_{\text{loss}}\rho M_{\text{loss}}^\dagger + M_{\text{gain}}\rho M_{\text{gain}}^\dagger + M_{\text{no}}\rho M_{\text{no}}^\dagger$$

where the operator M_{no} closed to \mathbf{I} and corresponding to no-loss and no-gain has to satisfy

$$M_{\text{loss}}^\dagger M_{\text{loss}} + M_{\text{gain}}^\dagger M_{\text{gain}} + M_{\text{no}}^\dagger M_{\text{no}} = \mathbf{I}.$$

Up to second order terms versus τ_a/T_{cav} we have

$$M_{\text{no}} = \mathbf{I} - (1+n_{\text{th}})\tau_a \frac{\tau_a}{2T_{\text{cav}}} \mathbf{a}^\dagger \mathbf{a} - n_{\text{th}}\tau_a \frac{\tau_a}{2T_{\text{cav}}} \mathbf{a}\mathbf{a}^\dagger.$$

The associated Kraus map reads then

$$\rho_+ = \rho + (1 + n_{\text{th}}) \frac{\tau_a}{T_{\text{cav}}} \left(\mathbf{a} \rho \mathbf{a}^\dagger - \frac{1}{2} \mathbf{a}^\dagger \mathbf{a} \rho - \frac{1}{2} \rho \mathbf{a}^\dagger \mathbf{a} \right) + n_{\text{th}} \frac{\tau_a}{T_{\text{cav}}} \left(\mathbf{a}^\dagger \rho \mathbf{a} - \frac{1}{2} \mathbf{a} \mathbf{a}^\dagger \rho - \frac{1}{2} \rho \mathbf{a} \mathbf{a}^\dagger \right).$$

Exploiting the fact that $\tau_a \ll T_{\text{cav}}$ (small sampling period τ_a) this equation becomes a differential equation:

$$\frac{\rho_+ - \rho}{\tau_a} \approx \frac{d}{dt} \rho = (1 + n_{\text{th}}) \kappa \left(\mathbf{a} \rho \mathbf{a}^\dagger - \frac{1}{2} \mathbf{a}^\dagger \mathbf{a} \rho - \frac{1}{2} \rho \mathbf{a}^\dagger \mathbf{a} \right) + n_{\text{th}} \kappa \left(\mathbf{a}^\dagger \rho \mathbf{a} - \frac{1}{2} \mathbf{a} \mathbf{a}^\dagger \rho - \frac{1}{2} \rho \mathbf{a} \mathbf{a}^\dagger \right). \quad (3.24)$$

This kind of equation will be investigated in next chapter on continuous-time open quantum systems.

3.3 Structure of discrete-time open quantum systems

The theory of open quantum systems starts with the contributions of Davies [29]. The goal of this section is first to present in an elementary way the general structure of the Markov models describing such systems. Throughout this section, \mathcal{H} is an Hilbert space; for each time-step $k \in \mathbb{N}$, ρ_k denotes the density operator describing the state of the quantum Markov process; for all k , ρ_k is an trace class operator on \mathcal{H} , Hermitian and of trace one.

3.3.1 Markov models

These models generalize the models developed for the photon box (3.22) merging quantum measurement and probability theory with classical probability through Bayesian estimation. Take a positive integer m and consider a finite set $(\mathbf{M}_\mu)_{\mu \in \{1, \dots, m\}}$ of operators on \mathcal{H} such that

$$\mathbf{I} = \sum_{\mu=1}^m \mathbf{M}_\mu^\dagger \mathbf{M}_\mu \quad (3.25)$$

Then each $\mathbf{M}_\mu \in \mathcal{L}(\mathcal{H})$. Take another positive integer m' and consider a left stochastic $m' \times m$ -matrix $(\eta_{\mu'\mu})$: its entries are non-negative and $\forall \mu \in \{1, \dots, m\}$, $\sum_{\mu'=1}^{m'} \eta_{\mu'\mu} = 1$. Consider the Markov process of state ρ and output $y \in \{1, \dots, m'\}$ (measurement outcome) defined via the transition rule

$$\rho_{k+1} = \frac{\sum_{\mu} \eta_{\mu' \mu} \mathbf{M}_\mu \rho_k \mathbf{M}_\mu^\dagger}{\text{Tr} \left(\sum_{\mu} \eta_{\mu' \mu} \mathbf{M}_\mu \rho_k \mathbf{M}_\mu^\dagger \right)}, \quad y_k = \mu' \text{ with probability } p_{\mu'}(\rho_k) \quad (3.26)$$

where $p_{\mu'}(\rho) = \text{Tr} \left(\sum_{\mu} \eta_{\mu' \mu} \mathbf{M}_\mu \rho \mathbf{M}_\mu^\dagger \right)$. The left stochastic matrix η yields to the decomposition of the Kraus map \mathbb{K} into the sum of m' partial Kraus maps $(\mathbb{K}_{\mu'})_{\mu' \in \{1, \dots, m'\}}$:

$$\mathbb{K}(\rho) = \sum_{\mu'=1}^{m'} \mathbb{K}_{\mu'}(\rho) \quad \text{with } \mathbb{K}_{\mu'}(\rho) = \sum_{\mu} \eta_{\mu' \mu} \mathbf{M}_\mu \rho \mathbf{M}_\mu^\dagger. \quad (3.27)$$

The Markov chain (3.26) reads:

$$\rho_{k+1} = \frac{\mathbb{K}_{\mu'}(\rho_k)}{\text{Tr} \left(\mathbb{K}_{\mu'}(\rho_k) \right)}, \quad y_k = \mu' \text{ with probability } p_{\mu'}(\rho_k) = \text{Tr} \left(\mathbb{K}_{\mu'}(\rho_k) \right). \quad (3.28)$$

3.3.2 Kraus and unital maps

The Kraus map \mathbb{K} corresponds to the master equation of (3.26). It is given by the expectation value of ρ_{k+1} knowing ρ_k :

$$\mathbb{K}(\rho) \triangleq \sum_{\mu} M_{\mu} \rho M_{\mu}^{\dagger} = \mathbb{E}(\rho_{k+1} / \rho_k = \rho). \quad (3.29)$$

In quantum information [50] such Kraus maps describe quantum channels. They admit many interesting properties. In particular, they are contractions for many metrics (see [51] for the characterization, in finite dimension, of metrics for which any Kraus map is a contraction). We just recall below two such metrics. For any density operators ρ and ρ' we have

$$D(\mathbb{K}(\rho), \mathbb{K}(\rho')) \leq D(\rho, \rho') \text{ and } F(\mathbb{K}(\rho), \mathbb{K}(\rho')) \geq F(\rho, \rho') \quad (3.30)$$

where the trace distance D and fidelity F are given by

$$D(\rho, \rho') \triangleq \text{Tr}(|\rho - \rho'|) \text{ and } F(\rho, \rho') \triangleq \text{Tr}^2\left(\sqrt{\sqrt{\rho}\rho'\sqrt{\rho}}\right). \quad (3.31)$$

Fidelity is between 0 and 1: $F(\rho, \rho') = 1$ if and only if, $\rho = \rho'$. Moreover $F(\rho, \rho') = F(\rho', \rho)$. If $\rho' = |\psi\rangle\langle\psi|$ is a pure state ($|\psi\rangle$ element of \mathcal{H} of length one), $F(\rho, \rho')$ coincides with the Frobenius product: $F(\rho, |\psi\rangle\langle\psi|) \equiv \text{Tr}(\rho|\psi\rangle\langle\psi|) = \langle\psi|\rho|\psi\rangle$. Kraus maps provide the evolution of open quantum systems from an initial state ρ_0 without information coming from the measurements (see [36, chapter 4: the environment is watching]):

$$\rho_{k+1} = \mathbb{K}(\rho_k) \text{ for } k = 0, 1, \dots, \dots \quad (3.32)$$

This corresponds to the "Schrödinger description" of the dynamics.

The "Heisenberg description" is given by the dual map \mathbb{K}^* . It is characterized by $\text{Tr}(\mathbf{A}\mathbb{K}(\rho)) = \text{Tr}(\mathbb{K}^*(\mathbf{A})\rho)$ and defined for any bounded operator \mathbf{A} on \mathcal{H} by

$$\mathbb{K}^*(\mathbf{A}) = \sum_{\mu} M_{\mu}^{\dagger} \mathbf{A} M_{\mu}.$$

Technical conditions on \mathbf{A} are required when \mathcal{H} is of infinite dimension, they are not given here (see, e.g., [29]). The map \mathbb{K}^* is unital since (3.25) reads $\mathbb{K}^*(\mathbf{I}) = \mathbf{I}$. As \mathbb{K} , the dual map \mathbb{K}^* admits a lot of interesting properties. It is noticed in [57] that, based on a theorem due of Birkhoff [14], such unital maps are contractions on the cone of non-negative Hermitian operators equipped with the Hilbert's projective metric. In particular, when \mathcal{H} is of finite dimension, we have, for any Hermitian operator \mathbf{A} :

$$\lambda_{\min}(\mathbf{A}) \leq \lambda_{\min}(\mathbb{K}^*(\mathbf{A})) \leq \lambda_{\max}(\mathbb{K}^*(\mathbf{A})) \leq \lambda_{\max}(\mathbf{A})$$

where λ_{\min} and λ_{\max} correspond to the smallest and largest eigenvalues. As shown in [52], such contraction properties based on Hilbert's projective metric have important implications in quantum information theory.

To emphasize the difference between the "Schrödinger description" and the "Heisenberg description" of the dynamics, let us translate convergence issues from the "Schrödinger description" to the "Heisenberg one". Assume, for clarity's sake, that \mathcal{H} is of finite dimension.

Suppose also that \mathbb{K} admits the density operator $\bar{\rho}$ as unique fixed point and that, for any initial density operator ρ_0 , the density operator at step k , ρ_k , defined by k iterations of \mathbb{K} , converges towards $\bar{\rho}$ when k tends to ∞ . Then $k \mapsto D(\rho_k, \bar{\rho})$ is decreasing and converges to 0 whereas $k \mapsto F(\rho_k, \bar{\rho})$ is increasing and converges to 1.

The translation of this convergence in the "Heisenberg description" is the following: for any initial operator \mathbf{A}_0 , its k iterates via \mathbb{K}^* , \mathbf{A}_k , converge towards $\text{Tr}(\mathbf{A}_0 \bar{\rho}) \mathbf{I}$. Moreover when \mathbf{A}_0 is Hermitian, $k \mapsto \lambda_{\min}(\mathbf{A}_k)$ and $k \mapsto \lambda_{\max}(\mathbf{A}_k)$ are respectively increasing and decreasing and both converge to $\text{Tr}(\mathbf{A}_0 \bar{\rho})$.

Notice finally that any bounded operator $\bar{\mathbf{A}}$ that is a fixed point of \mathbb{K}^* , $\mathbb{K}^*(\bar{\mathbf{A}}) = \bar{\mathbf{A}}$, yields to a constant of motion for $\rho_{k+1} = \mathbb{K}(\rho_k)$:

$$\text{Tr}(\bar{\mathbf{A}} \rho_k) = \text{Tr}(\bar{\mathbf{A}} \rho_0).$$

This means that, for any unraveling Markov process of the form (3.27), the stochastic variable $\text{Tr}(\bar{\mathbf{A}} \rho_k)$ is a martingale and is attached to fundamental properties of the dynamics (analogue of a priori estimates and first integral for (partial) differential equations).

3.3.3 Quantum filtering

Quantum filtering has its origin in Belavkin's work [13] on continuous-time open quantum systems (see next chapter). We just give here a discrete-time version. The state ρ_k of (3.28) is not directly measured: open quantum systems are governed by hidden-state Markov model. Quantum filtering provides an estimate ρ_k^{est} of ρ_k based on an initial guess ρ_0^{est} (possibly different from ρ_0) and the measurement outcomes y_l between 0 and $k-1$:

$$\rho_{l+1}^{\text{est}} = \frac{\mathbb{K}_{y_l}(\rho_l^{\text{est}})}{\text{Tr}(\mathbb{K}_{y_l}(\rho_l^{\text{est}}))}, \quad l \in \{0, \dots, k-1\}. \quad (3.33)$$

Thus $(\rho, \rho^{\text{est}})$ is the state of an extended Markov process governed by the following rule

$$\rho_{k+1} = \frac{\mathbb{K}_{\mu'}(\rho_k)}{\text{Tr}(\mathbb{K}_{\mu'}(\rho_k))} \quad \text{and} \quad \rho_{k+1}^{\text{est}} = \frac{\mathbb{K}_{\mu'}(\rho_k^{\text{est}})}{\text{Tr}(\mathbb{K}_{\mu'}(\rho_k^{\text{est}}))}$$

with transition probability $p_{\mu'}(\rho_k) = \text{Tr}(\mathbb{K}_{\mu'}(\rho_k))$ depending only on ρ_k .

When \mathcal{H} is of finite dimension, it is shown in [59] with an inequality proved in [53] that such discrete-time quantum filters are always stable in the following sense: the fidelity between ρ and its estimate ρ^{est} is a sub-martingale for any initial condition ρ_0 and ρ_0^{est} : $\mathbb{E}(F(\rho_{k+1}, \rho_{k+1}^{\text{est}}) \mid (\rho_k, \rho_k^{\text{est}})) \geq F(\rho_k, \rho_k^{\text{est}})$. This result does not guaranty that ρ_k^{est} converges to ρ_k when k tends to infinity. The convergence characterization of ρ^{est} towards ρ via checkable conditions on the partial Kraus maps $(\mathbb{K}_{\mu'})$ remains in general an open problem [66, 67]. For a recent convergence result under a purification assumption see [6].

Chapter 4

Continuous-time open systems

4.1 Lindblad master equation

The continuous-time analogue of the master equation (ensemble average dynamics) (3.32) becomes a differential equation for the time-evolution of the density operator $t \mapsto \rho(t)$:

$$\frac{d}{dt}\rho = -i[\mathbf{H}, \rho] + \sum_{\nu} L_{\nu}\rho L_{\nu}^{\dagger} - \frac{1}{2}(L_{\nu}^{\dagger}L_{\nu}\rho + \rho L_{\nu}^{\dagger}L_{\nu}) \quad (4.1)$$

where

- \mathbf{H} is the Hamiltonian that could depend on t (Hermitian operator on the underlying Hilbert space \mathcal{H})
- the L_{ν} 's are operators on \mathcal{H} that are not necessarily Hermitian.

The differential equation (4.1) preserves the positivity and the trace: if the initial condition ρ_0 is Hermitian of trace one and non-negative, then its solution $\rho(t)$ for $t \geq 0$ is also Hermitian, non-negative and of trace one. To avoid mathematical technicalities we consider in the theorem below that \mathcal{H} is of finite dimension.

Theorem 1. *Assume that \mathcal{H} is of finite dimension. Then for any Hermitian operator $t \mapsto \mathbf{H}(t)$ and any operators $L_{\nu}(t)$ that are L^1 functions of time, the solution of (4.1) with an initial condition ρ_0 Hermitian, non-negative and of trace one, is defined for all $t > 0$, remains Hermitian, non-negative and of trace one.*

Proof. The existence and uniqueness of the solution for $t > 0$ is consequence of a standard result on linear ordinary differential systems of finite dimension and with bounded and time-measurable coefficients. The Hermiticity and trace conservation directly follows from the fact that the right-hand side of (4.1) is Hermitian as soon as ρ is Hermitian, and admits a zero trace. The positivity conservation is less simple. It can be seen from the following formulation of (4.1):

$$\frac{d}{dt}\rho = \mathbf{A}\rho + \rho\mathbf{A}^{\dagger} + \sum_{\nu} L_{\nu}\rho L_{\nu}^{\dagger}$$

with $\mathbf{A} = -i\mathbf{H} - \frac{1}{2}\sum_{\nu} L_{\nu}^{\dagger}L_{\nu}$. Consider the solution of the matrix equation $\frac{d}{dt}\mathbf{E} = \mathbf{A}\mathbf{E}$ with $\mathbf{E}_0 = \mathbf{I}$. Then \mathbf{E} is always invertible and defines the following the change of variables

$\rho = \mathbf{E}\xi\mathbf{E}^\dagger$. We have then

$$\frac{d}{dt}\xi = \sum_{\nu} M_{\nu}\xi M_{\nu}^\dagger$$

with $M_{\nu} = \mathbf{E}^{-1}\mathbf{L}_{\nu}\mathbf{E}^{-1}$. The fact that $\xi_0 = \rho_0$ is Hermitian non-negative and that $\frac{d}{dt}\xi$ is also Hermitian and non-negative, implies that ξ remains non-negative for all $t > 0$, and thus ρ remains also non-negative. \square

The link between the discrete-time formulation (3.32) and the continuous-time one (4.1), becomes clear if we consider the following identity for ϵ positive and small:

$$\rho + \epsilon \frac{d}{dt}\rho = M_{\epsilon,0}\rho M_{\epsilon,0}^\dagger + \sum_{\nu} M_{\epsilon,\nu}\rho M_{\epsilon,\nu}^\dagger + O(\epsilon^2)$$

where $\frac{d}{dt}\rho$ is given by (4.1), $M_{\epsilon,0} = \mathbf{I} - \epsilon(i\mathbf{H} + \frac{1}{2}\sum_{\nu} L_{\nu}^\dagger L_{\nu})$ and $M_{\epsilon,\nu} = \sqrt{\epsilon}L_{\nu}$. Since $\rho(t + \epsilon) = \rho(t) + \epsilon \frac{d}{dt}\rho(t) + o(\epsilon)$ and $M_{\epsilon,0}^\dagger M_{\epsilon,0} + \sum_{\nu} M_{\epsilon,\nu}^\dagger M_{\epsilon,\nu} = \mathbf{I} + O(\epsilon^2)$, the continuous-time evolution (4.1) is attached to a discrete-time evolution similar to (3.32) with the following infinitesimal Kraus map

$$\rho(t + dt) = M_{dt,0}\rho(t)M_{dt,0}^\dagger + \sum_{\nu} M_{dt,\nu}\rho(t)M_{dt,\nu}^\dagger \quad (4.2)$$

up to second order terms versus the time-step $dt > 0$. Such correspondence can be used to develop positivity preserving numerical scheme (see, e.g., [42, 54]).

Since any Kraus map is a contraction for the trace-distance, we have the following theorem, the continuous-time counter part of subsection 3.3.2.

Theorem 2. *Consider two solutions of (4.1), ρ and ρ' , starting from ρ_0 and ρ'_0 two Hermitian non negative operators of trace one. Assume that \mathcal{H} is of finite dimension and the Hermitian operator $\mathbf{H}(t)$ and the operators $\mathbf{L}_{\nu}(t)$ are bounded and measurable functions of time. Then for any $0 \leq t_1 \leq t_2$,*

$$\text{Tr}(|\rho(t_2), \rho'(t_2)|) \leq \text{Tr}(|\rho(t_1), \rho'(t_1)|) \quad \text{and} \quad F(\rho(t_2), \rho'(t_2)) \geq F(\rho(t_1), \rho'(t_1)).$$

The proof just consists in exploiting (4.2) with (3.30).

4.2 Driven and damped quantum harmonic oscillator

4.2.1 Classical ordinary differential equations

Consider the following harmonic oscillator

$$\frac{d}{dt}x' = \omega p', \quad \frac{d}{dt}p' = -\omega x' - \kappa p' - 2u_1 \sin(\omega t) + 2u_2 \cos(\omega t)$$

where $\omega \gg \kappa$, $\sqrt{u_1^2 + u_2^2}$. Consider the following periodic change of variables $(x', p') \mapsto (x, p)$:

$$x' = \cos(\omega t)x + \sin(\omega t)p, \quad p' = -\sin(\omega t)x + \cos(\omega t)p.$$

Then, we have

$$\begin{aligned}\cos(\omega t)\frac{d}{dt}x + \sin(\omega t)\frac{d}{dt}p &= 0 \\ -\sin(\omega t)\frac{d}{dt}x + \cos(\omega t)\frac{d}{dt}p &= -\kappa(-\sin(\omega t)x + \cos(\omega t)p) - 2u_1 \sin(\omega t) + 2u_2 \cos(\omega t).\end{aligned}$$

Thus

$$\begin{aligned}\frac{d}{dt}x &= -\kappa \sin^2(\omega t)x + 2u_1 \sin^2(\omega t) + (\kappa p - 2u_2) \sin(\omega t) \cos(\omega t) \\ \frac{d}{dt}p &= -\kappa \cos^2(\omega t)p + 2u_2 \cos^2(\omega t) + (\kappa x - 2u_1) \sin(\omega t) \cos(\omega t).\end{aligned}$$

Removing highly oscillating terms (rotating wave approximation), we get:

$$\frac{d}{dt}x = -\frac{\kappa}{2}x + u_1, \quad \frac{d}{dt}p = -\frac{\kappa}{2}p + u_2$$

that reads also with the complex variables $\alpha = x + ip$ and $u = u_1 + iu_2$:

$$\frac{d}{dt}\alpha = -\frac{\kappa}{2}\alpha + u. \quad (4.3)$$

This yields to the following approximate model in the original frame (x', p') :

$$\frac{d}{dt}x' = -\frac{\kappa}{2}x' + \omega p + u_1 \cos(\omega t) + u_2 \sin(\omega t), \quad \frac{d}{dt}p' = -\omega x' - \frac{\kappa}{2}p' - u_1 \sin(\omega t) + u_2 \cos(\omega t)$$

or with complex variable $\alpha' = x' + ip' = e^{-i\omega t}\alpha$:

$$\frac{d}{dt}\alpha' = -\left(\frac{\kappa}{2} + i\omega\right)\alpha' + ue^{-i\omega t} \quad (4.4)$$

4.2.2 Quantum master equation

We consider here the quantum model of the classical oscillator modeled by (4.3) and (4.4). It admits the infinite dimensional Hilbert-space \mathcal{H} with $(|n\rangle)_{n \in \mathbb{N}}$ as ortho-normal basis (Fock states) (see section 1.1). Its Hamiltonian with a resonant coherent drive of complex amplitude u ($|u| \ll \omega$) reads

$$\mathbf{H} = \left(\omega \mathbf{N} + i(ue^{-i\omega t} \mathbf{a}^\dagger - u^* e^{i\omega t} \mathbf{a}) \right).$$

Consider as in (3.24), The Lindblad master equation (4.1) with the above \mathbf{H} and two operators $L_1 = \sqrt{(1 + n_{\text{th}})\kappa} \mathbf{a}$ and $L_2 = \sqrt{n_{\text{th}}\kappa} \mathbf{a}^\dagger$ corresponding to decoherence via photon losses and thermal photon gains. We get the following master equation where ρ' is the density operator:

$$\begin{aligned}\frac{d}{dt}\rho' &= -\omega[\mathbf{N}, \rho'] + [ue^{-i\omega t} \mathbf{a}^\dagger - u^* e^{i\omega t} \mathbf{a}, \rho'] + (1 + n_{\text{th}})\kappa \left(\mathbf{a}\rho'\mathbf{a}^\dagger - \frac{1}{2}\mathbf{a}^\dagger\mathbf{a}\rho' - \frac{1}{2}\rho'\mathbf{a}^\dagger\mathbf{a} \right) \\ &\quad + n_{\text{th}}\kappa \left(\mathbf{a}^\dagger\rho'\mathbf{a} - \frac{1}{2}\mathbf{a}\mathbf{a}^\dagger\rho' - \frac{1}{2}\rho'\mathbf{a}\mathbf{a}^\dagger \right). \quad (4.5)\end{aligned}$$

with parameter $\kappa > 0$ and $n_{\text{th}} \geq 0$. When $n_{\text{th}} = 0$, we recover (4.4) with $\alpha' = \text{Tr}(\rho'\mathbf{a})$.

Consider the change of frame $\rho' = e^{-i\omega t N} \rho e^{i\omega t N}$. Since $e^{i\omega t N} \mathbf{a} e^{-i\omega t N} = e^{-i\omega t} \mathbf{a}$, we get:

$$\begin{aligned} \frac{d}{dt} \rho = [u \mathbf{a}^\dagger - u^* \mathbf{a}, \rho] + (1 + n_{\text{th}}) \kappa \left(\mathbf{a} \rho \mathbf{a}^\dagger - \frac{1}{2} \mathbf{a}^\dagger \mathbf{a} \rho - \frac{1}{2} \rho \mathbf{a}^\dagger \mathbf{a} \right) \\ + n_{\text{th}} \kappa \left(\mathbf{a}^\dagger \rho \mathbf{a} - \frac{1}{2} \mathbf{a} \mathbf{a}^\dagger \rho - \frac{1}{2} \rho \mathbf{a} \mathbf{a}^\dagger \right). \end{aligned} \quad (4.6)$$

When $n_{\text{th}} = 0$, we recover with $\alpha = \text{Tr}(\rho \mathbf{a})$ the classical amplitude equation (4.3).

The above models (4.5) and (4.6) are valid only when $\omega \gg \kappa, |u|$: weak drive amplitude and high quality factor of the oscillator. With initial conditions ρ'_0 and ρ_0 being density operators (Hermitian non-negative trace-class operators on \mathcal{H} of trace one, see appendix B), their solutions give the forward time evolution of ρ' and ρ . In the sequel, we focus on the dynamics of ρ , i.e., on the dynamics in the frame rotating at the oscillator pulsation ω .

4.2.3 Zero temperature case: $n_{\text{th}} = 0$

Assume that $n_{\text{th}} = 0$:

$$\frac{d}{dt} \rho = [u \mathbf{a}^\dagger - u^* \mathbf{a}, \rho] + \kappa \left(\mathbf{a} \rho \mathbf{a}^\dagger - \frac{1}{2} \mathbf{a}^\dagger \mathbf{a} \rho - \frac{1}{2} \rho \mathbf{a}^\dagger \mathbf{a} \right).$$

Set $\bar{\alpha} = \frac{2u}{\kappa}$. We recover the classical equation for the complex amplitude $\alpha = \text{Tr}(\rho \mathbf{a})$:

$$\frac{d}{dt} \alpha = -\frac{\kappa}{2} (\alpha - 2u/\kappa) = -\frac{\kappa}{2} (\alpha - \bar{\alpha}).$$

Consider the following change of frame

$$\rho = e^{\bar{\alpha} \mathbf{a}^\dagger - \bar{\alpha}^* \mathbf{a}} \xi e^{-\bar{\alpha} \mathbf{a}^\dagger + \bar{\alpha}^* \mathbf{a}}$$

corresponding to a displacement of amplitude $-\bar{\alpha}$ of ρ . Since $e^{-\bar{\alpha} \mathbf{a}^\dagger + \bar{\alpha}^* \mathbf{a}} \mathbf{a} e^{\bar{\alpha} \mathbf{a}^\dagger - \bar{\alpha}^* \mathbf{a}} = \mathbf{a} + \bar{\alpha}$ and $e^{-\bar{\alpha} \mathbf{a}^\dagger + \bar{\alpha}^* \mathbf{a}} \mathbf{a}^\dagger e^{\bar{\alpha} \mathbf{a}^\dagger - \bar{\alpha}^* \mathbf{a}} = \mathbf{a}^\dagger + \bar{\alpha}^*$ we have

$$\begin{aligned} \frac{d}{dt} \xi = [u(\mathbf{a}^\dagger + \bar{\alpha}^*) - u^*(\mathbf{a} + \bar{\alpha}), \xi] + \kappa \left((\mathbf{a} + \bar{\alpha}) \xi (\mathbf{a}^\dagger + \bar{\alpha}^*) - \frac{1}{2} (\mathbf{a}^\dagger + \bar{\alpha}^*) (\mathbf{a} + \bar{\alpha}) \xi - \frac{1}{2} \xi (\mathbf{a}^\dagger + \bar{\alpha}^*) (\mathbf{a} + \bar{\alpha}) \right) \\ = \kappa \left(\mathbf{a} \xi \mathbf{a}^\dagger - \frac{1}{2} \mathbf{a}^\dagger \mathbf{a} \xi - \frac{1}{2} \xi \mathbf{a}^\dagger \mathbf{a} \right). \end{aligned}$$

Consider $V(\xi) = \text{Tr}(\xi \mathbf{N})$ ($\mathbf{N} = \mathbf{a}^\dagger \mathbf{a}$). Since ξ is a density operator $V(\xi) \geq 0$ and $V(\xi) = 0$ if, and only if, $\xi = |0\rangle\langle 0|$ (vacuum state). We have

$$\frac{d}{dt} V(\xi) = -\kappa V(\xi).$$

If the initial energy $V(\xi_0) < +\infty$, $\xi(t)$ remains of finite energy for all t and moreover, $V(\xi(t)) = V(\xi_0) e^{-\kappa t}$. Thus $V(\xi(t))$ tends to 0 and thus $\xi(t)$ converges towards $|0\rangle\langle 0|$. Since ρ is just ξ up to a coherent displacement $\bar{\alpha}$, this proves that $\rho(t)$ converges towards $|\bar{\alpha}\rangle\langle \bar{\alpha}|$, the coherent and pure state of amplitude $\bar{\alpha}$.

The above arguments with the strict Lyapunov function V are not presented here above with all the necessarily mathematical rigour since \mathcal{H} is an infinite dimensional Hilbert space. Nevertheless, they can be made rigorous to prove the following theorem

Theorem 3. Consider (4.6) with $u \in \mathbb{C}$, $\kappa > 0$ and $n_{th} = 0$. Denote by $|\bar{\alpha}\rangle$ the coherent state of complex amplitude $\bar{\alpha} = \frac{2u}{\kappa}$. Assume that the initial state ρ_0 is a density operator with finite energy $\text{Tr}(\rho_0 \mathbf{N}) < +\infty$. Then exists a unique solution to the Cauchy problem (4.6) initialized with ρ_0 in the the Banach space $\mathcal{K}^1(\mathcal{H})$ (see appendix B). It is defined for all $t > 0$ with $t \mapsto \rho(t)$ a density operator (Hermitian, non-negative and trace-class) that remains in the domain of the Lindblad super-operator

$$\rho \mapsto [u\mathbf{a}^\dagger - u^*\mathbf{a}, \rho] + \kappa \left(\mathbf{a}\rho\mathbf{a}^\dagger - \frac{1}{2}\mathbf{a}^\dagger\mathbf{a}\rho - \frac{1}{2}\rho\mathbf{a}^\dagger\mathbf{a} \right).$$

Thus $t \mapsto \rho(t)$ is differentiable in the Banach space $\mathcal{K}^1(\mathcal{H})$. Moreover $\rho(t)$ converges for the trace-norm towards $|\bar{\alpha}\rangle\langle\bar{\alpha}|$ when t tends to $+\infty$.

The following lemma gives the link with the classical damped oscillator.

Lemma 2. Consider (4.6) with $u \in \mathbb{C}$, $\kappa > 0$ and $n_{th} = 0$.

1. for any initial density operator ρ_0 with $\text{Tr}(\rho_0 \mathbf{N}) < +\infty$, we have $\frac{d}{dt}\alpha = -\frac{\kappa}{2}(\alpha - \bar{\alpha})$ where $\alpha = \text{Tr}(\rho\mathbf{a})$.
2. Assume that $\rho_0 = |\beta_0\rangle\langle\beta_0|$ where β_0 is some complex amplitude. Then for all $t \geq 0$, $\rho(t) = |\beta(t)\rangle\langle\beta(t)|$ remains a coherent and pure state of amplitude $\beta(t)$ solution of the following equation: $\frac{d}{dt}\beta = -\frac{\kappa}{2}(\beta - \bar{\alpha})$ with $\beta(0) = \beta_0$.

Proof. Statement 1 follows from $\frac{d}{dt}\alpha = \text{Tr}(\mathbf{a}\frac{d}{dt}\rho)$ with $\frac{d}{dt}\rho$ given by (4.6). Statement 2 relies on the following relationships specific to coherent state:

$$\mathbf{a}|\beta\rangle = \beta|\beta\rangle, \quad |\beta\rangle = e^{-\frac{\beta\beta^*}{2}} e^{\beta\mathbf{a}^\dagger}|0\rangle \quad \text{and} \quad \frac{d}{dt}|\beta\rangle = \left(-\frac{1}{2}(\beta^*\dot{\beta} + \beta\dot{\beta}^*) + \dot{\beta}\mathbf{a}^\dagger \right) |\beta\rangle.$$

□

4.2.4 Wigner function and quantum Fokker-Planck equation

For an harmonic oscillator of space dimension 1, the phase space is the plane (x, p) . To represent this quantum state and its link with classical statistical physics, it is useful to consider the Wigner function $\mathbb{R}^2 \ni (x, p) \mapsto W^{\{\rho\}}(x, p) \in \mathbb{R}$ attached to the density operator ρ . For a physical interpretation of $W^{\{\rho\}}$ as a pseudo-probability density see appendix of [36] where the Wigner function is defined via the Fourier transform

$$W^{\{\rho\}}(x, p) = \frac{1}{\pi^2} \iint_{\mathbb{R}^2} C_s^{\{\rho\}}(\lambda_1 + i\lambda_2) e^{-2i(x\lambda_2 - p\lambda_1)} d\lambda_1 d\lambda_2$$

of the symmetric characteristic function $C_s^{\{\rho\}}$ attached to ρ (quantum probability):

$$\mathbb{C} \ni \lambda_1 + i\lambda_2 = \lambda \mapsto C_s^{\{\rho\}}(\lambda) = \text{Tr} \left(\rho e^{\lambda\mathbf{a}^\dagger - \lambda^*\mathbf{a}} \right).$$

We will use here the following definition,

$$W^{\{\rho\}}(x, p) = \frac{2}{\pi} \text{Tr} \left(\rho \mathbf{D}_\alpha e^{i\pi\mathbf{N}} \mathbf{D}_{-\alpha} \right) \quad \text{with} \quad \alpha = x + ip, \quad (4.7)$$

where $D_\alpha = e^{\alpha a^\dagger - \alpha^* a}$ is the displacement of complex amplitude α . Consequently $W^{\{\rho\}}(x, p)$ is real and well defined since $D_\alpha e^{i\pi N} D_{-\alpha}$ is a bounded, unitary and Hermitian operator (the dual of $\mathcal{K}^1(\mathcal{H})$ is $\mathcal{B}(\mathcal{H})$, see appendix B).

For a coherent state $\rho = |\beta\rangle\langle\beta|$ with $\beta \in \mathbb{C}$ we have

$$W^{\{|\beta\rangle\langle\beta|\}}(x, p) = \frac{2}{\pi} \langle\beta| D_\alpha e^{i\pi N} D_{-\alpha} |\beta\rangle = \frac{2}{\pi} e^{-2|\beta-\alpha|^2}.$$

since $\langle\beta| D_\alpha = \langle\beta - \alpha|$ with $D_{-\alpha} |\beta\rangle = |\beta - \alpha\rangle$ and $e^{i\pi N} |\beta - \alpha\rangle = |\alpha - \beta\rangle$. Thus $W^{\{|\beta\rangle\langle\beta|\}}$ is the usual Gaussian density function centered on β in the phase plane $\alpha = x + ip$ and of variance $1/2$ in all directions.

In the sequel we will consider that ρ is in $\mathcal{K}^f(\mathcal{H})$ (support with a finite number of photons) and thus that the computations here below can be done without any divergence problem. Using $D_\alpha = e^{\alpha a^\dagger} e^{-\alpha^* a} e^{-\alpha\alpha^*/2} = e^{-\alpha^* a} e^{\alpha a^\dagger} e^{\alpha\alpha^*/2}$ we have two equivalent formulations:

$$\frac{\pi}{2} W^{\{\rho\}}(\alpha, \alpha^*) = \text{Tr} \left(\rho e^{\alpha a^\dagger} e^{-\alpha^* a} e^{i\pi N} e^{\alpha^* a} e^{-\alpha a^\dagger} \right) = \text{Tr} \left(\rho e^{-\alpha^* a} e^{\alpha a^\dagger} e^{i\pi N} e^{-\alpha a^\dagger} e^{\alpha^* a} \right)$$

Here α and α^* are seen as independent variables. We have the following correspondence:

$$\frac{\partial}{\partial \alpha} = \frac{1}{2} \left(\frac{\partial}{\partial x} - i \frac{\partial}{\partial p} \right), \quad \frac{\partial}{\partial \alpha^*} = \frac{1}{2} \left(\frac{\partial}{\partial x} + i \frac{\partial}{\partial p} \right)$$

We have

$$\frac{\pi}{2} \frac{\partial}{\partial \alpha} W^{\{\rho\}}(\alpha, \alpha^*) = \text{Tr} \left((\rho a^\dagger - a^\dagger \rho) e^{\alpha a^\dagger} e^{-\alpha^* a} e^{i\pi N} e^{\alpha^* a} e^{-\alpha a^\dagger} \right) = \text{Tr} \left((\rho a^\dagger - a^\dagger \rho) D_\alpha e^{i\pi N} D_{-\alpha} \right)$$

Since $a^\dagger D_\alpha e^{i\pi N} D_{-\alpha} = D_\alpha e^{i\pi N} D_{-\alpha} (2\alpha^* - a^\dagger)$, we have

$$\frac{\partial}{\partial \alpha} W^{\{\rho\}}(\alpha, \alpha^*) = 2\alpha^* W^{\{\rho\}}(\alpha, \alpha^*) - 2W^{\{a^\dagger \rho\}}(\alpha, \alpha^*).$$

Thus $W^{\{a^\dagger \rho\}}(\alpha, \alpha^*) = \alpha^* W^{\{\rho\}}(\alpha, \alpha^*) - \frac{1}{2} \frac{\partial}{\partial \alpha} W^{\{\rho\}}(\alpha, \alpha^*)$.

Similar computations yield to the following correspondence rules:

$$\begin{aligned} W^{\{\rho a\}} &= \left(\alpha - \frac{1}{2} \frac{\partial}{\partial \alpha^*} \right) W^{\{\rho\}}, & W^{\{a \rho\}} &= \left(\alpha + \frac{1}{2} \frac{\partial}{\partial \alpha^*} \right) W^{\{\rho\}} \\ W^{\{\rho a^\dagger\}} &= \left(\alpha^* + \frac{1}{2} \frac{\partial}{\partial \alpha} \right) W^{\{\rho\}}, & W^{\{a^\dagger \rho\}} &= \left(\alpha^* - \frac{1}{2} \frac{\partial}{\partial \alpha} \right) W^{\{\rho\}}. \end{aligned}$$

With these rules the differential equation (4.6) for ρ becomes a partial differential equation for $W^{\{\rho\}}(x, p)$. We have

$$\begin{aligned} W^{\{[ua^\dagger - u^* a, \rho]\}} &= - \left(u \frac{\partial}{\partial \alpha} + u^* \frac{\partial}{\partial \alpha^*} \right) W^{\{\rho\}} \\ W^{\{a \rho a^\dagger - \frac{a^\dagger a \rho + \rho a^\dagger a}{2}\}} &= \frac{1}{2} \left(\frac{\partial^2}{\partial \alpha \partial \alpha^*} + \frac{\partial}{\partial \alpha} \alpha + \frac{\partial}{\partial \alpha^*} \alpha^* \right) W^{\{\rho\}} \\ W^{\{a^\dagger \rho a - \frac{a a^\dagger \rho + \rho a a^\dagger}{2}\}} &= \frac{1}{2} \left(\frac{\partial^2}{\partial \alpha \partial \alpha^*} - \frac{\partial}{\partial \alpha} \alpha - \frac{\partial}{\partial \alpha^*} \alpha^* \right) W^{\{\rho\}}. \end{aligned}$$

Consequently, the time-varying Wigner function $W^{\{\rho\}}$ is governed by a partial differential equation

$$\frac{\partial}{\partial t} W^{\{\rho\}} = \frac{\kappa}{2} \left(\frac{\partial}{\partial \alpha} (\alpha - \bar{\alpha}) + \frac{\partial}{\partial \alpha^*} (\alpha^* - \bar{\alpha}^*) + (1 + 2n_{\text{th}}) \frac{\partial^2}{\partial \alpha \partial \alpha^*} \right) W^{\{\rho\}}$$

with $\bar{\alpha} = 2u/\kappa$. Set $\bar{\alpha} = \bar{x} + i\bar{p}$. Using $\frac{\partial}{\partial \alpha}$ and $\frac{\partial}{\partial \alpha^*}$ as linear expressions in $\frac{\partial}{\partial x}$ and $\frac{\partial}{\partial p}$, we get finally the following convection diffusion equation also called quantum Fokker Planck equation:

$$\frac{\partial}{\partial t} W^{\{\rho\}} = \frac{\kappa}{2} \left(\frac{\partial}{\partial x} \left((x - \bar{x}) W^{\{\rho\}} \right) + \frac{\partial}{\partial p} \left((p - \bar{p}) W^{\{\rho\}} \right) + \frac{1+2n_{\text{th}}}{4} \left(\frac{\partial^2 W^{\{\rho\}}}{\partial x^2} + \frac{\partial^2 W^{\{\rho\}}}{\partial p^2} \right) \right). \quad (4.8)$$

It can be also written in a more geometric form with $\nabla = \begin{pmatrix} \frac{\partial}{\partial x} \\ \frac{\partial}{\partial p} \end{pmatrix}$:

$$\frac{\partial}{\partial t} W^{\{\rho\}} = -\nabla \cdot (W^{\{\rho\}} F) + \nabla \cdot (\sigma \nabla W^{\{\rho\}})$$

where $F = \frac{\kappa}{2} \begin{pmatrix} \bar{x} - x \\ \bar{y} - y \end{pmatrix}$ and $\sigma = \frac{\kappa(1+2n_{\text{th}})}{8}$.

The Green function $G(x, p, t, x_0, p_0)$ of (4.8), i.e., its solution with initial condition $W_0^{\{\rho\}}(x, p) = \delta(x - x_0)\delta(p - p_0)$ where δ is the Dirac distribution, reads:

$$G(x, p, t, x_0, p_0) = \frac{1}{\pi(n_{\text{th}} + \frac{1}{2})(1 - e^{-\kappa t})} \exp \left(- \frac{\left(x - \bar{x} - (x_0 - \bar{x})e^{-\frac{\kappa t}{2}} \right)^2 + \left(p - \bar{p} - (p_0 - \bar{p})e^{-\frac{\kappa t}{2}} \right)^2}{(n_{\text{th}} + \frac{1}{2})(1 - e^{-\kappa t})} \right).$$

The general solution of (4.8) with an L^1 initial condition $W_0^{\{\rho\}}(x, p)$ ($\iint_{\mathbb{R}^2} |W_0^{\{\rho\}}(x, p)| < +\infty$), reads for $t > 0$:

$$W_t^{\{\rho\}}(x, p) = \int_{\mathbb{R}^2} W_0^{\{\rho\}}(x', p') G(x, p, t, x', p') dx' dp'.$$

For t large, $G(x, p, t, x', p')$ converges toward a Gaussian distribution independent of (x', p') . By application of the dominate convergence theorem we have:

$$\forall (x, p) \in \mathbb{R}^2, \quad \lim_{t \rightarrow +\infty} W_t^{\{\rho\}}(x, p) = \frac{\iint_{\mathbb{R}^2} W_0^{\{\rho\}}}{\pi(n_{\text{th}} + \frac{1}{2})} \exp \left(- \frac{(x - \bar{x})^2 + (p - \bar{p})^2}{(n_{\text{th}} + \frac{1}{2})} \right).$$

Notice that Wigner functions associated to density operators satisfy $\iint_{\mathbb{R}^2} W^{\{\rho\}} = 1$. Thus the steady state solution of (4.8) is a Gaussian probability density centered on (\bar{x}, \bar{p}) with variance $(n_{\text{th}} + \frac{1}{2})$ in all direction. Moreover any trajectory of (4.8) initialized with $W^{\{\rho_0\}}$, ρ_0 being a density operator, converge to this Gaussian function. When $n_{\text{th}} = 0$, we recover the Wigner function of the coherent state $\bar{\alpha}$.

Many other properties on Wigner and related functions can be founded in [36] and also in [23].

4.3 Adiabatic elimination of a low-Q harmonic oscillator

This section is mainly based on [8] relying on coordinate free setting due to Fenichel [33] of singular perturbations for deterministic dynamical systems. For a summary of such coordinate free setting see appendix G.

Take a small parameter $0 < \epsilon \ll 1$. Consider the following composite system made of subsystem A with an arbitrary Hilbert space \mathcal{H}_A and subsystem B with the Hilbert space of a quantum harmonic oscillator $\mathcal{H}_B = \text{span}\{|n_b\rangle \mid n_b \in \mathbb{N}\}$ (usual called buffer mode \mathbf{b}):

$$\frac{d}{dt}\boldsymbol{\rho} = \mathcal{L}_0(\boldsymbol{\rho}) + \epsilon\mathcal{L}_1(\boldsymbol{\rho}) \quad (4.9)$$

where

- $\mathcal{L}_0(\boldsymbol{\rho}) = \kappa_b(\mathbf{b}\boldsymbol{\rho}\mathbf{b}^\dagger - (\mathbf{b}^\dagger\mathbf{b}\boldsymbol{\rho} + \boldsymbol{\rho}\mathbf{b}^\dagger\mathbf{b})/2)$ with $\kappa_b > 0$ and \mathbf{b} the annihilation operator on harmonic oscillator B ;
- $\mathcal{L}_1(\boldsymbol{\rho}) = -i[\mathbf{H}_{\text{int}}, \boldsymbol{\rho}] + \mathcal{L}_A(\boldsymbol{\rho})$ with \mathcal{L}_A a Lindbladian dynamics of form (4.1) on sub-system A only, with an interaction Hamiltonian $\mathbf{H}_{\text{int}} = \sum_{k=1}^m \mathbf{A}_k \otimes \mathbf{B}_k$, with \mathbf{A}_k and \mathbf{B}_k Hermitian operators on \mathcal{H}_A and \mathcal{H}_B respectively.

The solution $\bar{\boldsymbol{\rho}}_B = |0_b\rangle\langle 0_b|$ of $\mathcal{L}_0(\boldsymbol{\rho}) = 0$ corresponds to vacuum in mode \mathbf{b} . The slow manifold is directly connected to $\boldsymbol{\rho}_A = \text{Tr}_B(\boldsymbol{\rho})$, the partial trace of $\boldsymbol{\rho}$ versus sub-system B . In particular it has the dimension of the space of density operators on sub-system A . We are looking for a parametrization preserving the fact that $\boldsymbol{\rho}_A$ remains always a density operator and including first order terms in ϵ attached to possible entanglement between A and B . We add thus to the series expansions (G.3) of appendix G

$$\frac{d}{dt}\xi = \epsilon\mathcal{F}_1(\xi) + \epsilon^2\mathcal{F}_2(\xi) + \dots \quad \text{and} \quad \boldsymbol{\rho} = \mathcal{K}_0(\xi) + \epsilon\mathcal{K}_1(\xi) + \epsilon^2\mathcal{K}_2(\xi) + \dots$$

the following constrains:

- $\epsilon\mathcal{F}_1 + \epsilon^2\mathcal{F}_2$ has to be of Lindblad form, up-to $O(\epsilon^3)$ corrections;
- $\mathcal{K}_0 + \epsilon\mathcal{K}_1 + \epsilon^2\mathcal{K}_2$ has to be a Kraus map up-to $O(\epsilon^3)$ corrections.

Here ξ is an operator on sub-system A parameterizing $\boldsymbol{\rho}_A$ via the Kraus map

$$\xi \mapsto \text{Tr}_B(\mathcal{K}_0(\xi) + \epsilon\mathcal{K}_1(\xi) + \epsilon^2\mathcal{K}_2(\xi) + \dots) = \boldsymbol{\rho}_A.$$

It is important to notice here that ξ does not coincide in general exactly with $\text{Tr}_B(\boldsymbol{\rho})$.

Then (G.4) reads here

$$\begin{aligned} (\mathcal{L}_0 + \epsilon\mathcal{L}_1)(\mathcal{K}_0(\xi) + \epsilon\mathcal{K}_1(\xi) + \epsilon^2\mathcal{K}_2(\xi) + \dots) \\ = (\mathcal{K}_0 + \epsilon\mathcal{K}_1 + \epsilon^2\mathcal{K}_2 + \dots)(\epsilon\mathcal{F}_1(\xi) + \epsilon^2\mathcal{F}_2(\xi) + \dots). \end{aligned}$$

It is clear that for $\epsilon = 0$, order 0 term $\mathcal{L}_0(\mathcal{K}_0(\xi)) = 0$ implies that

$$\mathcal{K}_0(\xi) = \xi \otimes |0_b\rangle\langle 0_b|$$

when we impose that ξ and $\text{Tr}_B(\boldsymbol{\rho})$ coincides when $\epsilon = 0$.

Since all the maps are linear, identifying terms of order one give an equation satisfied by \mathcal{F}_1 and \mathcal{K}_1 :

$$\mathcal{L}_0(\mathcal{K}_1(\xi)) + \mathcal{L}_1(\mathcal{K}_0(\xi)) = \mathcal{K}_0(\mathcal{F}_1(\xi)). \quad (4.10)$$

Since $\text{Tr}_B(\mathcal{L}_0(\rho)) \equiv 0$ for any operator ρ on $\mathcal{H}_A \otimes \mathcal{H}_B$,

$$\mathcal{L}_1(\mathcal{K}_0(\xi)) = -i \left[\sum_{k=1}^m \mathbf{A}_k \otimes \mathbf{B}_k, \xi \otimes |0_b\rangle\langle 0_b| \right] + \mathcal{L}_A(\xi) \otimes |0_b\rangle\langle 0_b|$$

and $\mathcal{K}_0(\mathcal{F}_1(\xi)) = \mathcal{F}_1(\xi) \otimes |0_b\rangle\langle 0_b|$, taking the partial trace versus sub-system B gives

$$\mathcal{F}_1(\xi) = -i \left[\sum_k \beta_k \mathbf{A}_k, \xi \right] + \mathcal{L}_A(\xi) \quad \text{with} \quad \beta_k = \langle 0_b | \mathbf{B}_k | 0_b \rangle \in \mathbb{R}.$$

With such $\mathcal{F}_1(\xi)$, (4.10) becomes

$$\mathcal{L}_0(\mathcal{K}_1(\xi)) = -i \left[\sum_{k=1}^m \mathbf{A}_k \otimes (\mathbf{B}_k - \beta_k), \xi \otimes |0_b\rangle\langle 0_b| \right] \quad (4.11)$$

The equation

$$\mathcal{L}_0(\mathbf{X}) = \mathbf{B}|0_b\rangle\langle 0_b|$$

for the unknown operator \mathbf{X} on B and the given operator \mathbf{B} on \mathcal{H}_B operator admits solutions if, and only if, $\text{Tr}(\mathbf{B}|0_b\rangle\langle 0_b|) = \langle 0_b | \mathbf{B} | 0_b \rangle = 0$. Then its general solution reads

$$\mathbf{X} = -\frac{2}{\kappa_b} (\mathbf{b}^\dagger \mathbf{b})^{-1} \mathbf{B} |0_b\rangle\langle 0_b| + g |0_b\rangle\langle 0_b|$$

where $(\mathbf{b}^\dagger \mathbf{b})^{-1}$ is the Moore-Penrose inverse of $\mathbf{b}^\dagger \mathbf{b}$ and g is any complex number. This comes from the identity $\mathbf{b}^\dagger \mathbf{b} (\mathbf{b}^\dagger \mathbf{b})^{-1} = (\mathbf{b}^\dagger \mathbf{b})^{-1} \mathbf{b}^\dagger \mathbf{b} = \mathbf{I}_B - |0_b\rangle\langle 0_b|$. Similarly by Hermitian conjugation, the solution of $\mathcal{L}_0(\mathbf{X}) = |0_b\rangle\langle 0_b| \mathbf{B}$ when $\langle 0_b | \mathbf{B} | 0_b \rangle = 0$ reads $\mathbf{X} = |0_b\rangle\langle 0_b| \mathbf{B} (\mathbf{b}^\dagger \mathbf{b})^{-1} + g |0_b\rangle\langle 0_b|$.

Notice that (4.11) reads

$$\mathcal{L}_0(\mathcal{K}_1(\xi)) = \sum_{k=1}^m -i \mathbf{A}_k \xi \otimes (\mathbf{B}_k - \beta_k) |0_b\rangle\langle 0_b| + i \xi \mathbf{A}_k \otimes |0_b\rangle\langle 0_b| (\mathbf{B}_k - \beta_k).$$

Since $\beta_k = \langle 0_b | \mathbf{B}_k | 0_b \rangle$ for each k , it admits the following general solution

$$\begin{aligned} \mathcal{K}_1(\xi) &= \mathbf{G}(\xi) \otimes |0_b\rangle\langle 0_b| + \frac{2i}{\kappa_b} \sum_{k=1}^m \mathbf{A}_k \xi \otimes (\mathbf{b}^\dagger \mathbf{b})^{-1} \mathbf{B}_k |0_b\rangle\langle 0_b| - \xi \mathbf{A}_k \otimes |0_b\rangle\langle 0_b| \mathbf{B}_k (\mathbf{b}^\dagger \mathbf{b})^{-1} \\ &= \mathbf{G}(\xi) \otimes |0_b\rangle\langle 0_b| + \frac{2i}{\kappa_b} \left[\sum_k \mathbf{A}_k \otimes \left((\mathbf{b}^\dagger \mathbf{b})^{-1} \mathbf{B}_k + \mathbf{B}_k (\mathbf{b}^\dagger \mathbf{b})^{-1} \right), \xi \otimes |0_b\rangle\langle 0_b| \right] \end{aligned}$$

where $\mathbf{G}(\xi)$ is any operator on \mathcal{H}_A , a gauge degree of freedom depending on ξ , and where we have used $(\mathbf{b}^\dagger \mathbf{b})^{-1} |0_b\rangle = 0 = \langle 0_b | (\mathbf{b}^\dagger \mathbf{b})^{-1}$. We have

$$\mathcal{K}_0(\xi) + \epsilon \mathcal{K}_1(\xi) = e^{i\epsilon \mathbf{W}_1} (\xi \otimes |0_b\rangle\langle 0_b|) e^{-i\epsilon \mathbf{W}_1} + \epsilon \mathbf{G}(\xi) \otimes |0_b\rangle\langle 0_b| + O(\epsilon^2) \quad (4.12)$$

where

$$\mathbf{W}_1 = \frac{2}{\kappa_b} \sum_{k=1}^m \mathbf{A}_k \otimes ((\mathbf{b}^\dagger \mathbf{b})^{-1} \mathbf{B}_k + \mathbf{B}_k (\mathbf{b}^\dagger \mathbf{b})^{-1}) \quad (4.13)$$

is Hermitian.

In the sequel we choose $G(\xi) = 0$ in order to have $\xi = \text{Tr}_B(\rho) + 0(\epsilon^2)$ in the corresponding first order reduced model:

$$\frac{d}{dt} \xi = -i\epsilon \left[\sum_k \beta_k \mathbf{A}_k, \xi \right] + \epsilon \mathcal{L}_A(\xi), \quad \rho = e^{i\epsilon \mathbf{W}_1} (\xi \otimes |0_b\rangle \langle 0_b|) e^{-i\mathbf{W}_1}.$$

where $e^{i\epsilon \mathbf{W}_1}$ is unitary on $\mathcal{H}_A \otimes \mathcal{H}_B$ close to identity.

The second order corrections \mathcal{F}_2 and \mathcal{K}_2 are solution of

$$\mathcal{L}_0(\mathcal{K}_2(\xi)) + \mathcal{L}_1(\mathcal{K}_1(\xi)) = \mathcal{K}_0(\mathcal{F}_2(\xi)) + \mathcal{K}_1(\mathcal{F}_1(\xi)). \quad (4.14)$$

Taking the trace versus B , we get $\mathcal{F}_2(\xi) = \text{Tr}_B(\mathcal{K}_1(\mathcal{F}_1(\xi)) - \mathcal{L}_1(\mathcal{K}_1(\xi)))$. We have directly $\text{Tr}_B(\mathcal{K}_1(\mathcal{F}_1(\xi))) = 0$. Since

$$\begin{aligned} \mathcal{L}_1(\mathcal{K}_1(\xi)) &= \frac{2}{\kappa_b} \left[\sum_k \mathbf{A}_k \otimes \mathbf{B}_k, \sum_{k'} \mathbf{A}_{k'} \xi \otimes (\mathbf{b}^\dagger \mathbf{b})^{-1} \mathbf{B}_{k'} |0_b\rangle \langle 0_b| - \xi \mathbf{A}_{k'} \otimes |0_b\rangle \langle 0_b| \mathbf{B}_{k'} (\mathbf{b}^\dagger \mathbf{b})^{-1} \right] \\ &\quad + \frac{2i}{\kappa_b} \sum_{k'} \mathcal{L}_A(\mathbf{A}_{k'} \xi) \otimes (\mathbf{b}^\dagger \mathbf{b})^{-1} \mathbf{B}_{k'} |0_b\rangle \langle 0_b| - \mathcal{L}_A(\xi \mathbf{A}_{k'}) \otimes |0_b\rangle \langle 0_b| \mathbf{B}_{k'} (\mathbf{b}^\dagger \mathbf{b})^{-1}, \end{aligned}$$

the partial trace versus B yields to

$$\begin{aligned} \frac{\kappa_b}{2} \text{Tr}_B(\mathcal{L}_1(\mathcal{K}_1(\xi))) &= \sum_{k,k'} \langle 0_b | \mathbf{B}_k (\mathbf{b}^\dagger \mathbf{b})^{-1} \mathbf{B}_{k'} |0_b\rangle \mathbf{A}_k \mathbf{A}_{k'} \xi - \langle 0_b | \mathbf{B}_{k'} (\mathbf{b}^\dagger \mathbf{b})^{-1} \mathbf{B}_k |0_b\rangle \mathbf{A}_k \xi \mathbf{A}_{k'} \\ &\quad - \sum_{k,k'} \langle 0_b | \mathbf{B}_k (\mathbf{b}^\dagger \mathbf{b})^{-1} \mathbf{B}_{k'} |0_b\rangle \mathbf{A}_{k'} \xi \mathbf{A}_k - \langle 0_b | \mathbf{B}_{k'} (\mathbf{b}^\dagger \mathbf{b})^{-1} \mathbf{B}_k |0_b\rangle \xi \mathbf{A}_{k'} \mathbf{A}_k. \end{aligned}$$

With Gram matrix of entries

$$G_{kk'} = \langle 0_b | \mathbf{B}_k (\mathbf{b}^\dagger \mathbf{b})^{-1} \mathbf{B}_{k'} |0_b\rangle = \sum_{n_b=1}^{+\infty} \left(\frac{1}{\sqrt{n_b}} \langle n_b | \mathbf{B}_k |0_b\rangle \right)^* \left(\frac{1}{\sqrt{n_b}} \langle n_b | \mathbf{B}_{k'} |0_b\rangle \right) \quad (4.15)$$

and its Cholesky factorization $G = \Lambda^\dagger \Lambda$, one gets

$$\frac{\kappa_b}{2} \text{Tr}_B(\mathcal{L}_1(\mathcal{K}_1(\xi))) = \sum_{k,k',k''} \Lambda_{k''k}^* \Lambda_{k''k'} \left(\mathbf{A}_k \mathbf{A}_{k'} \xi + \xi \mathbf{A}_k \mathbf{A}_{k'} - 2 \mathbf{A}_{k'} \xi \mathbf{A}_k \right)$$

since $G_{kk'} = \sum_{k''} \Lambda_{k''k}^* \Lambda_{k''k'}$. Set

$$\mathbf{L}_k = \sum_{k'=1}^m \Lambda_{k,k'} \mathbf{A}_{k'} \quad (4.16)$$

Then $\frac{\kappa_b}{2} \text{Tr}_B(\mathcal{L}_1(\mathcal{K}_1(\xi))) = \sum_k \left(\mathbf{L}_k^\dagger \mathbf{L}_k \xi + \xi \mathbf{L}_k^\dagger \mathbf{L}_k - 2 \mathbf{L}_k \xi \mathbf{L}_k^\dagger \right)$. Finally, one obtains with gauge $\mathbf{G}(\xi) = 0$ for \mathcal{K}_1 ,

$$\mathcal{F}_2(\xi) = \frac{4}{\kappa_b} \left(\sum_k \mathbf{L}_k \xi \mathbf{L}_k^\dagger - \frac{1}{2} \left(\mathbf{L}_k^\dagger \mathbf{L}_k \xi + \xi \mathbf{L}_k^\dagger \mathbf{L}_k \right) \right) \quad (4.17)$$

To conclude, the slow dynamics of ρ governed by (4.9) can be approximated by the following trace and positivity preserving reduced model of state ξ a density operator on \mathcal{H}_A

$$\begin{aligned} \frac{d}{dt}\xi = & -i\epsilon \left[\sum_k \beta_k \mathbf{A}_k, \xi \right] + \epsilon \mathcal{L}_A(\xi) \\ & + \frac{4\epsilon^2}{\kappa_b} \left(\sum_k \mathbf{L}_k \xi \mathbf{L}_k^\dagger - \frac{1}{2} \left(\mathbf{L}_k^\dagger \mathbf{L}_k \xi + \xi \mathbf{L}_k^\dagger \mathbf{L}_k \right) \right) + O(\epsilon^3) \end{aligned} \quad (4.18)$$

with $\rho = e^{i\epsilon \mathbf{W}_1} (\xi \otimes |0_b\rangle\langle 0_b|) e^{-i\epsilon \mathbf{W}_1} + O(\epsilon^2)$ as completely positive and trace preserving output map providing the physical quantum state ρ on $\mathcal{H}_A \otimes \mathcal{H}_B$. Here $\beta_k = \langle 0_b | \mathbf{B}_k | 0_b \rangle$, the Lindblad operators \mathbf{L}_k are given by (4.16) and the Hermitian operator by (4.13). Notice that ξ coincides with $\text{Tr}_B(\rho)$ up to second-order correction in ϵ .

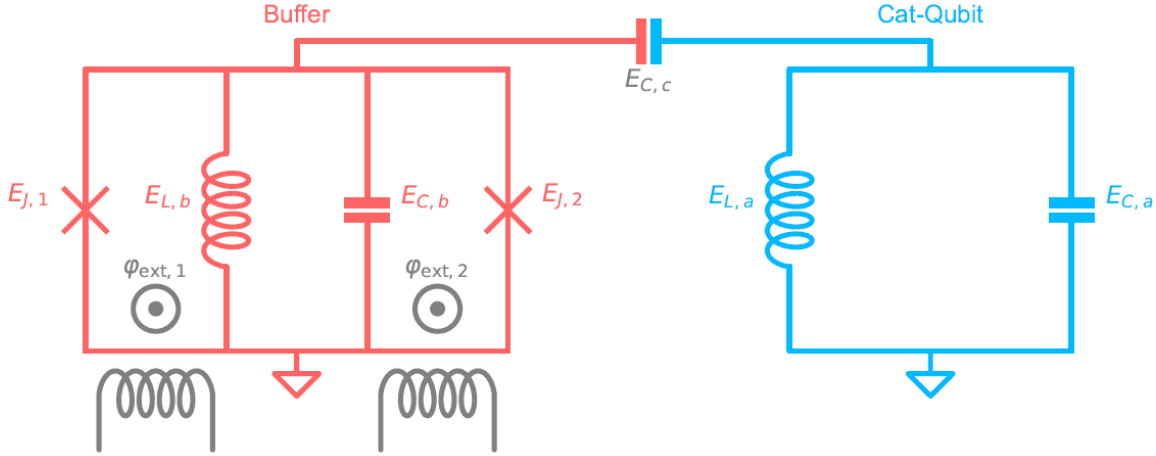

Figure 4.1: The super-conducting quantum circuit of [43, figure S3] stabilizes Schrödinger phase-cats of the high-quality oscillator \mathbf{a} with pulsation ω_a (in blue) via nonlinear (Josephson junctions) and oscillatory (pulsation $2\omega_a - \omega_b$) Hamiltonian coupling to a low quality oscillator \mathbf{b} of pulsation ω_b (in red).

4.4 Autonomous stabilization of a cat-qubit

This section details on a slightly simplified Hamiltonian the mathematical methods used to analyze the super-conducting circuit illustrated on figure 4.1 and stabilizing any quantum state ρ of an oscillator with support in the vector space spanned by two coherent states $|\alpha\rangle$ and $|\alpha\rangle$ with $\alpha \neq 0$ a complex amplitude. This circuit implements autonomous quantum error correction and is directly related to bosonic quantum code, a possible and actively investigated path for building a universal quantum computer (see the seminal paper [49]).

We detail below perturbation techniques, rotating wave approximation (averaging) and adiabatic elimination (singular perturbation), yielding to reduced dynamical models for the oscillator supporting these Schrödinger cats, i.e. storing quantum information attached to a logical qubit (**cat-qubit**). The time asymptotic behavior of these reduced models are then analyzed with Lyapunov techniques showing exponential convergence.

4.4.1 The classical analysis

For simplicity sake, we consider here the following classical Hamiltonian encoding similar drives and weak nonlinearities as those of the ATS-circuit considered in [43, appendix]:

$$H(q_a, p_a, q_b, p_b, t) = \frac{\omega_a}{2}(q_a^2 + p_a^2) + \frac{\omega_b}{2}(q_b^2 + p_b^2) + 2g \cos\left(\sqrt{2}\phi_a q_a + \sqrt{2}\phi_b q_b + (2\omega_a - \omega_b)t\right) \quad (4.19)$$

where (q_a, p_a) and (q_b, p_b) are the canonical phase-space variables attached to oscillators a et b respectively. Here $\omega_a \neq \omega_b$ are their pulsations, g the coupling parameter is small, i.e.

$|g| \ll \omega_a, \omega_b$, and the positive parameters $\phi_a, \phi_b \ll 1$. The dynamics read

$$\begin{aligned} \frac{d}{dt}q_a &= \omega_a p_a, & \frac{d}{dt}p_a &= -\omega_a q_a + 2ig\sqrt{2}\phi_a \sin\left(\sqrt{2}\phi_a q_a + \sqrt{2}\phi_b q_b + (2\omega_a - \omega_b)t\right) \\ \frac{d}{dt}q_b &= \omega_b p_b, & \frac{d}{dt}p_b &= -\omega_b q_b - \kappa_b p_b + 2ig\sqrt{2}\phi_b \sin\left(\sqrt{2}\phi_a q_a + \sqrt{2}\phi_b q_b + (2\omega_a - \omega_b)t\right) \\ & & & + v \cos \omega_b t + w \sin \omega_b t \end{aligned}$$

where we have added on oscillator b a **weak damping rate** ($0 < \kappa_b \ll \omega_b$) and a resonant input drive with $|v|, |w| \ll \omega_b$.

With complex variable $z_a = (q_a + ip_a)/\sqrt{2}$ and $z_b = (q_b + ip_b)/\sqrt{2}$, one gets

$$\begin{aligned} \frac{d}{dt}z_a &= -i\omega_a z_a + 2ig\phi_a \sin\left(\phi_a(z_a + z_a^*) + \phi_b(z_b + z_b^*) + (2\omega_a - \omega_b)t\right) \\ \frac{d}{dt}z_b &= -i\omega_b z_b - \frac{\kappa_b}{2}(z_b - z_b^*) + 2ig\phi_b \sin\left(\phi_a(z_a + z_a^*) + \phi_b(z_b + z_b^*) + (2\omega_a - \omega_b)t\right) \\ & + ue^{-i\omega_b t} - u^* e^{i\omega_b t} \end{aligned}$$

with $(w + iv)/2\sqrt{2} = u \in \mathbb{C}$.

The **time-varying change of variables** $z_a = \bar{z}_a e^{-i\omega_a t}$ and $z_b = \bar{z}_b e^{-i\omega_b t}$ yields to

$$\begin{aligned} \frac{d}{dt}\bar{z}_a &= 2ig\phi_a e^{i\omega_a t} \sin\left(\phi_a(\bar{z}_a e^{-i\omega_a t} + \bar{z}_a^* e^{+i\omega_a t}) + \phi_b(\bar{z}_b e^{-i\omega_b t} + \bar{z}_b^* e^{+i\omega_b t}) + (2\omega_a - \omega_b)t\right) \\ \frac{d}{dt}\bar{z}_b &= -\frac{\kappa_b}{2}(\bar{z}_b - \bar{z}_b^* e^{2i\omega_b t}) + u - u^* e^{2i\omega_b t} \\ & + 2ig\phi_b e^{i\omega_b t} \sin\left(\phi_a(\bar{z}_a e^{-i\omega_a t} + \bar{z}_a^* e^{+i\omega_a t}) + \phi_b(\bar{z}_b e^{-i\omega_b t} + \bar{z}_b^* e^{+i\omega_b t}) + (2\omega_a - \omega_b)t\right). \end{aligned}$$

First order **averaging** based on asymptotic expansion up-to order 3 versus $\phi_a, \phi_b \ll 1$ (weak non-linearity) gives with $g_2 = \frac{g\phi_a^2\phi_b}{2}$

$$\frac{d}{dt}\bar{z}_a = 2g_2 \bar{z}_a^* \bar{z}_b, \quad \frac{d}{dt}\bar{z}_b = u - g_2 \bar{z}_a^2 - \frac{\kappa_b}{2} \bar{z}_b.$$

This nonlinear system on \mathbb{C}^2 admits 2 stable steady-states $(\bar{z}_a, \bar{z}_b) = (\pm\alpha, 0)$ with $\alpha^2 = u/g_2$ and an unstable one $(0, 2u/\kappa_b)$.

When $\kappa_b \gg |g_2|$, \bar{z}_b relaxes rapidly to $2(u - g_2 \bar{z}_a^2)/\kappa_b$: the slow evolution of \bar{z}_a obeys to

$$\frac{d}{dt}\bar{z}_a = -\frac{4g_2^2}{\kappa_b} \bar{z}_a^* (\bar{z}_a^2 - \alpha^2) \tag{4.20}$$

where we have replaced in $\frac{d}{dt}\bar{z}_a$ equation, \bar{z}_b by its value given by the usual **quasi-static approximation** $0 = u - g_2 \bar{z}_a^2 - \frac{\kappa_b}{2} \bar{z}_b$ (Tikhonov normal form, see sub-section G.2).

This reduced system on \mathbb{C} derives from the potential (**Lyapunov function**) (see [43, appendix])

$$V(\bar{z}_a, \bar{z}_a^*) = \frac{4g_2^2}{2\kappa_b} ((\bar{z}_a^*)^2 - \alpha^2)(\bar{z}_a^2 - \alpha^2) = \frac{4g_2^2}{2\kappa_b} |\bar{z}_a^2 - \alpha^2|^2$$

since the above slow dynamics reads

$$\frac{d}{dt}\bar{z}_a = -\frac{\partial V}{\partial \bar{z}_a^*}.$$

It admits three steady states, the three critical points of V : two exponentially stable steady-states $\pm\alpha$ where V reaches its minimum, one exponentially unstable steady-state 0 corresponding to a saddle point for V . Since the critical points of V are non degenerate (Hessian of V with rank 2), these steady-states are all hyperbolic, either locally exponentially stable or unstable. Moreover V is infinite at infinity. Thus the solutions of this slow model are defined for any positive time t . Almost of them converge either to α or $-\alpha$ except those converging to 0 and located on the straight line passing to the origin with direction $i\alpha$. This line corresponds to the stable manifold (here a straight line) of the saddle steady-state. It is also the frontier between the attraction domains of locally exponentially stable steady-states α and $-\alpha$.

4.4.2 The quantum analysis

The quantum Hamiltonian corresponding to the classical slightly simplified Hamiltonian (4.19) is as follows:

$$\mathbf{H}_1(t) = \omega_a \mathbf{a}^\dagger \mathbf{a} + \omega_b \mathbf{b}^\dagger \mathbf{b} + 2g \cos \left(\phi_a (\mathbf{a} + \mathbf{a}^\dagger) + \phi_b (\mathbf{b} + \mathbf{b}^\dagger) + (2\omega_a - \omega_b)t\mathbf{I} \right) \quad (4.21)$$

where $\mathbf{a} = (q_a + \frac{\partial}{\partial q_a})/\sqrt{2}$ and $\mathbf{b} = (q_b + \frac{\partial}{\partial q_b})/\sqrt{2}$ are the annihilation operators on oscillators a and b respectively ($[\mathbf{a}, \mathbf{a}^\dagger] = \mathbf{I}_a$, $[\mathbf{b}, \mathbf{b}^\dagger] = \mathbf{I}_b$). The density operator ρ_1 obeys to the usual Liouville equation: $\frac{d}{dt}\rho_1 = -i[\mathbf{H}_1(t), \rho_1]$.

The **change of frame**

$$\rho_2 = \exp \left(i\omega_a t \mathbf{a}^\dagger \mathbf{a} + i\omega_b t \mathbf{b}^\dagger \mathbf{b} \right) \rho_1 \exp \left(-i\omega_a t \mathbf{a}^\dagger \mathbf{a} - i\omega_b t \mathbf{b}^\dagger \mathbf{b} \right)$$

yields to $\frac{d}{dt}\rho_2 = -i[\mathbf{H}_2(t), \rho_2]$ with the new Hamiltonian

$$\mathbf{H}_2(t) = g e^{i(2\omega_a - \omega_b)t} \exp \left(i\phi_a (e^{-i\omega_a t} \mathbf{a} + e^{i\omega_a t} \mathbf{a}^\dagger) + i\phi_b (e^{-i\omega_b t} \mathbf{b} + e^{i\omega_b t} \mathbf{b}^\dagger) \right) + h.c.$$

Expansion up-to order 3 versus $\phi_a, \phi_b \ll 1$ of the exponential gives

$$\begin{aligned} \mathbf{H}_2(t) &\approx g e^{i(2\omega_a - \omega_b)t} \dots \\ &\left(\mathbf{I} + i\phi_a (e^{-i\omega_a t} \mathbf{a} + e^{i\omega_a t} \mathbf{a}^\dagger) - \frac{\phi_a^2}{2} (e^{-i\omega_a t} \mathbf{a} + e^{i\omega_a t} \mathbf{a}^\dagger)^2 - \frac{i\phi_a^3}{6} (e^{-i\omega_a t} \mathbf{a} + e^{i\omega_a t} \mathbf{a}^\dagger)^3 \right) \dots \\ &\left(\mathbf{I} + i\phi_b (e^{-i\omega_b t} \mathbf{b} + e^{i\omega_b t} \mathbf{b}^\dagger) - \frac{\phi_b^2}{2} (e^{-i\omega_b t} \mathbf{b} + e^{i\omega_b t} \mathbf{b}^\dagger)^2 - \frac{i\phi_b^3}{6} (e^{-i\omega_b t} \mathbf{b} + e^{i\omega_b t} \mathbf{b}^\dagger)^3 \right) \\ &+ h.c. \quad (4.22) \end{aligned}$$

Following the multi-frequency averaging of sub-sections 2.1.1 and 2.1.2, one gets at first order **only two secular terms** (i.e. non-oscillatory): $-ig_2 \mathbf{a}^2 \mathbf{b}^\dagger$ and its Hermitian conjugate $ig_2 (\mathbf{a}^\dagger)^2 \mathbf{b}$ where $g_2 = g\phi_a^2 \phi_b / 2$. This justifies the following first-order time-invariant approximation where the oscillatory $\mathbf{H}_2(t)$ is replaced by its time-invariant averaged $\overline{\mathbf{H}}_2$ (**rotating wave approximation**): :

$$\overline{\mathbf{H}}_2 = -ig_2 \mathbf{a}^2 \mathbf{b}^\dagger + ig_2 (\mathbf{a}^\dagger)^2 \mathbf{b}.$$

Exercice 12. *Instead of Hamiltonian given by (4.21), consider*

$$\mathbf{H}_1(t) = \omega_a \mathbf{a}^\dagger \mathbf{a} + \omega_b \mathbf{b}^\dagger \mathbf{b} + 2g \cos \left(\phi_a (\mathbf{a} + \mathbf{a}^\dagger) + \phi_b (\mathbf{b} + \mathbf{b}^\dagger) + (2\omega_a - \omega_b)t\mathbf{I} \right) + iue^{-i\omega_b t} \mathbf{b}^\dagger - iu^* e^{i\omega_b t} \mathbf{b}$$

with u complex amplitude associated to a resonant input drive on mode \mathbf{b} . Show that a similar first-order RWA yields to

$$\overline{\mathbf{H}}_2 = i(u - g_2 \mathbf{a}^2) \mathbf{b}^\dagger - i(u^* - g_2 (\mathbf{a}^\dagger)^2) \mathbf{b}.$$

Exercise 13. Use approximation recipes of (2.15) to compute second-order corrections to $\overline{\mathbf{H}}_2$ for oscillatory Hamiltonian $\mathbf{H}_2(t)$ given by (4.22)

In the frame rotating at frequencies of oscillators a and b , the density operator ρ obeys to the following master equation

$$\begin{aligned} \frac{d}{dt} \rho &= \mathcal{L}_{ab}(\rho) \\ &\triangleq - \left[g_2 (\mathbf{a}^2 - \alpha^2) \mathbf{b}^\dagger - g_2 ((\mathbf{a}^\dagger)^2 - (\alpha^*)^2) \mathbf{b}, \rho \right] + \kappa_b \left(\mathbf{b} \rho \mathbf{b}^\dagger - (\mathbf{b}^\dagger \mathbf{b} \rho + \rho \mathbf{b}^\dagger \mathbf{b}) / 2 \right) \end{aligned} \quad (4.23)$$

where, for mode b , we have added a damping rate $\kappa_b > 0$ and also a resonant drive of frequency ω_b and complex amplitude u (see exercise 12) providing $\alpha^2 = u/g_2 \in \mathbb{C}$.

Exercise 14. Show that $\mathcal{L}_{ab}(|z_1\rangle\langle z_2| \otimes |0_b\rangle\langle 0_b|) = 0$ for $z_1, z_2 \in \{\alpha, -\alpha\}$. Deduce that any density operator $\bar{\rho} = \bar{\rho}_a \otimes |0_b\rangle\langle 0_b|_b$ is a steady-state as soon the range of $\bar{\rho}_a$ belongs to $\text{span}\{|\alpha\rangle, |-\alpha\rangle\}$.

Assume that $\kappa_b \gg g_2$, i.e., that dissipation of mode \mathbf{b} to vacuum $|0_b\rangle$ is the dominant dynamics in \mathcal{L}_{ab} . Following section 4.3, we can eliminated adiabatically mode b to get a Lindblad master equation only for mode a .

Exercise 15. Consider (4.9). Show that \mathcal{L}_{ab} reads $\mathcal{L}_0 + \epsilon \mathcal{L}_1$ with $\epsilon = g_2$, $\mathcal{L}_A = 0$ and

$$\mathbf{A}_1 = \alpha^2 + (\alpha^*)^2 - (\mathbf{a}^2 + \mathbf{a}^\dagger)^2, \quad \mathbf{B}_1 = \frac{\mathbf{b} - \mathbf{b}^\dagger}{2i}, \quad \mathbf{A}_2 = i(\alpha^2 - (\alpha^*)^2 - (\mathbf{a}^2 - \mathbf{a}^\dagger)^2), \quad \mathbf{B}_2 = \frac{\mathbf{b} + \mathbf{b}^\dagger}{2}.$$

With exercise 15 we have, according to (4.13), $\mathbf{W}_1 = 0$ and to (4.15)

$$G = \frac{1}{4} \begin{pmatrix} 1 & -i \\ i & 1 \end{pmatrix} = \frac{1}{4} \begin{pmatrix} 1 & 0 \\ i & 0 \end{pmatrix} \begin{pmatrix} 1 & -i \\ 0 & 0 \end{pmatrix}.$$

With $\Lambda = \frac{1}{2} \begin{pmatrix} 1 & -i \\ 0 & 0 \end{pmatrix}$ we get, using (4.16), $\mathbf{L}_1 = \alpha^2 - \mathbf{a}^2$ and $\mathbf{L}_2 = 0$. Finally the following slow evolution of mode a is given by

$$\begin{aligned} \frac{d}{dt} \rho_A &= \frac{4g_2^2}{\kappa_b} \left((\mathbf{a}^2 - \alpha^2) \rho_A (\mathbf{a}^2 - \alpha^2)^\dagger \right. \\ &\quad \left. - ((\mathbf{a}^2 - \alpha^2)^\dagger (\mathbf{a}^2 - \alpha^2) \rho_A + \rho_A (\mathbf{a}^2 - \alpha^2)^\dagger (\mathbf{a}^2 - \alpha^2)) / 2 \right) \end{aligned} \quad (4.24)$$

where $\rho = \rho_A \otimes |0_b\rangle\langle 0_b| + O((g_2/\kappa_b)^2)$ and $\rho_A = \text{Tr}_B(\rho)$.

Exercise 16. Take (4.24) and assume that ρ_A is initialized to the coherent state of amplitude z_a : $\rho_a(0) = |z_a\rangle\langle z_a|$. Show that $\frac{d}{dt} \text{Tr}(\alpha \rho_A)$ at time 0 is given by (4.20).

It is clear that any density operators $\bar{\rho}_a$ is a steady-state as soon as the support of $\bar{\rho}_a$ belongs to the two dimensional vector space spanned by the quasi-classical wave functions $|\alpha\rangle$ and $|\alpha\rangle$ (range($\bar{\rho}_a$) \subset span $\{|\alpha\rangle, |\alpha\rangle\}$). In particular any coherent superposition of $|\alpha\rangle$ and $|\alpha\rangle$ is a steady state such as Schrödinger phase cat $|\alpha\rangle + |\alpha\rangle$. In [9] well-posedness of this master equation and exponential convergence of $\rho_A(t)$ towards such a ρ_A are proved with the following Lyapunov function $V(\rho_A) = \text{Tr}((\mathbf{a}^2 - \alpha^2)^\dagger(\mathbf{a}^2 - \alpha^2)\rho_A)$. This results from the following key identity

$$\frac{d}{dt}V(\rho_A) = -\frac{8g_2^2}{\kappa_b} \text{Tr} \left((\mathbf{a}^2 - \alpha^2)^\dagger (2\mathbf{a}^\dagger \mathbf{a} + \mathbf{I}_a) (\mathbf{a}^2 - \alpha^2) \rho_A \right) \leq -\frac{8g_2^2}{\kappa_b} V(\rho_A)$$

exploiting the fact that $[(\mathbf{a}^2 - \alpha^2)^\dagger, (\mathbf{a}^2 - \alpha^2)] = -2(2\mathbf{a}^\dagger \mathbf{a} + \mathbf{I}_a)$.

4.5 Stochastic master equations

These models have their origins in the work of Davies [29], are related to quantum trajectories [22, 28] and to Belavkin quantum filters [13].

4.5.1 Diffusive case

A modern and mathematical exposure of the diffusive models is given in [10]. These models are interpreted here as continuous-time versions of (3.28). They are based on stochastic differential equations, also called Stochastic Master Equations (SME). They provide the evolution of the density operator ρ_t with respect to the time t . They are driven by a finite number of independent Wiener processes indexed by ν , ($W_{\nu,t}$), each of them being associated to a continuous classical and real signal, $y_{\nu,t}$, produced by detector ν . These SMEs admit the following form:

$$d\rho_t = \left(-i[\mathbf{H}, \rho_t] + \sum_{\nu} \mathbf{L}_{\nu} \rho_t \mathbf{L}_{\nu}^\dagger - \frac{1}{2}(\mathbf{L}_{\nu}^\dagger \mathbf{L}_{\nu} \rho_t + \rho_t \mathbf{L}_{\nu}^\dagger \mathbf{L}_{\nu}) \right) dt + \sum_{\nu} \sqrt{\eta_{\nu}} \left(\mathbf{L}_{\nu} \rho_t + \rho_t \mathbf{L}_{\nu}^\dagger - \text{Tr} \left((\mathbf{L}_{\nu} + \mathbf{L}_{\nu}^\dagger) \rho_t \right) \rho_t \right) dW_{\nu,t} \quad (4.25)$$

where \mathbf{H} is the Hamiltonian operator on the underlying Hilbert space \mathcal{H} and \mathbf{L}_{ν} are arbitrary operators (not necessarily Hermitian) on \mathcal{H} . Each measured signal $y_{\nu,t}$ is related to ρ_t and $W_{\nu,t}$ by the following output relationship:

$$dy_{\nu,t} = dW_{\nu,t} + \sqrt{\eta_{\nu}} \text{Tr} \left((\mathbf{L}_{\nu} + \mathbf{L}_{\nu}^\dagger) \rho_t \right) dt$$

where $\eta_{\nu} \in [0, 1]$ is the efficiency of detector ν .

For the case of a finite dimensional Hilbert space, it has been proven in [48, 10] that the above SME admits a unique strong solution in the space of well-defined density matrices

$$\mathcal{S} = \{\rho \mid \rho = \rho^\dagger, \rho \geq 0, \text{Tr}(\rho) = 1\}.$$

When all η_{ν} vanish, (4.25) boils down to a deterministic differential equation usually called Lindblad master equation (more precisely Gorini–Kossakowski–Sudarshan–Lindblad equation

(GKSL)). This linear differential equation governs the ensemble average of ρ_t [38, 46]:

$$\frac{d}{dt}\rho = -i[\mathbf{H}, \rho] + \sum_{\nu} \mathbf{L}_{\nu}\rho_t\mathbf{L}_{\nu}^{\dagger} - \frac{1}{2}(\mathbf{L}_{\nu}^{\dagger}\mathbf{L}_{\nu}\rho_t + \rho_t\mathbf{L}_{\nu}^{\dagger}\mathbf{L}_{\nu}). \quad (4.26)$$

It is the continuous-time analogue of the Kraus map \mathbf{K} associated to the Markov process (3.29).

In fact (3.26) and (4.25) have the same structure. This becomes obvious if one remarks that, with standard Itô rules, (4.25) admits the following formulation

$$\rho_{t+dt} = \frac{\mathbf{M}_{dy_t}\rho_t\mathbf{M}_{dy_t}^{\dagger} + \sum_{\nu}(1 - \eta_{\nu})\mathbf{L}_{\nu}\rho_t\mathbf{L}_{\nu}^{\dagger}dt}{\text{Tr}\left(\mathbf{M}_{dy_t}\rho_t\mathbf{M}_{dy_t}^{\dagger} + \sum_{\nu}(1 - \eta_{\nu})\mathbf{L}_{\nu}\rho_t\mathbf{L}_{\nu}^{\dagger}dt\right)}$$

with $\mathbf{M}_{dy_t} = \mathbf{I} + (-i\mathbf{H} - \frac{1}{2}\sum_{\nu}\mathbf{L}_{\nu}^{\dagger}\mathbf{L}_{\nu})dt + \sum_{\nu}\sqrt{\eta_{\nu}}dy_{\nu t}\mathbf{L}_{\nu}$. Moreover the probability associated to the measurement outcome $dy = (dy_{\nu})$, is given by the following density

$$\begin{aligned} p\left(dy \in \prod_{\nu}[\xi_{\nu}, \xi_{\nu} + d\xi_{\nu}] \mid \rho_t\right) \\ = \text{Tr}\left(\mathbf{M}_{\xi}\rho_t\mathbf{M}_{\xi}^{\dagger} + \sum_{\nu}(1 - \eta_{\nu})\mathbf{L}_{\nu}\rho_t\mathbf{L}_{\nu}^{\dagger}dt\right) \prod_{\nu} \frac{d\xi_{\nu}}{\sqrt{2\pi dt}} e^{-\xi_{\nu}^2/2dt} \end{aligned}$$

where ξ stands for the vector (ξ_{ν}) . With such a formulation, it becomes clear that (4.25) preserves the trace and the non-negativity of ρ . This formulation provides also directly a time discretization numerical scheme preserving non-negativity of ρ .

We recall here the basic rule of Itô differential calculus for the stochastic system of state $X \in \mathbb{R}^n$ and driven by m scalar Wiener independent processes $W_{\nu,t}$:

$$X_{t+dt} - X_t = dX_t = F(X_t, t)dt + \sum_{\nu} G_{\nu}(X_t, t)dW_{\nu,t}$$

where $F(X, t)$ and $(G_{\nu}(X, t))$ are smooth functions of X and piece-wise continuous functions of t . For any C^2 real function f of X , the computation of $df_t = f(X_{t+dt}) - f(X_t)$ is conducted up to including order one in dt with the following rules: $dW_{\nu,t} = O(\sqrt{dt})$, $(dW_{\nu,t})^2 = dt$, $dW_{\nu,t}dW_{\nu',t} = 0$ for $\nu \neq \nu'$ and any other products between the $dW_{\nu,t}$ being zero since of order greater than $(dt)^{3/2}$. This means that we have

$$\begin{aligned} df_t &= f(X_{t+dt}) - f(X_t) = f(X_t + dX_t) - f(X_t) \\ &= \frac{\partial f}{\partial X}\Big|_{X_t} dX_t + \frac{1}{2} \frac{\partial^2 f}{\partial X^2}\Big|_{X_t} (dX_t, dX_t) + \dots \\ &= \left(\frac{\partial f}{\partial X}\Big|_{X_t} F(X_t, t) + \frac{1}{2} \sum_{\nu} \frac{\partial^2 f}{\partial X^2}\Big|_{X_t} (G_{\nu}(X_t, t), G_{\nu}(X_t, t)) \right) dt \\ &\quad + \sum_{\nu} \frac{\partial f}{\partial X}\Big|_{X_t} G_{\nu}(X_t, t)dW_{\nu,t}. \end{aligned}$$

Notice that we have removed terms with $dt dW_{\nu,t}$ since of order $dt^{3/2}$. For expectation values, all $dW_{\nu,t}$ are independent of X_t and $\mathbb{E}(dW_{\nu,t}) = 0$. Thus we have for any C^2 function f of X :

$$\mathbb{E}(df_t \mid X_t) = \left(\frac{\partial f}{\partial X}\Big|_{X_t} F(X_t, t) + \frac{1}{2} \sum_{\nu} \frac{\partial^2 f}{\partial X^2}\Big|_{X_t} (G_{\nu}(X_t, t), G_{\nu}(X_t, t)) \right) dt.$$

4.5.2 Jump case

This section just adds measurement imperfections to the quantum Monte Carlo trajectories introduced in [28] and well explained in [36][chapter 4]. More details can be found [54, 4].

Jump stochastic master equations are driven by Poisson processes, i.e. counting processes ($N_\mu(t)$), instead of Wiener ones. They admits the following structure:

$$d\rho_t = \left(-i[\mathbf{H}, \rho_t] + \sum_{\mu} \mathbf{V}_{\mu} \rho_t \mathbf{V}_{\mu}^{\dagger} - \frac{1}{2}(\mathbf{V}_{\mu}^{\dagger} \mathbf{V}_{\mu} \rho_t + \rho_t \mathbf{V}_{\mu}^{\dagger} \mathbf{V}_{\mu}) \right) dt + \sum_{\mu} \left(\frac{\bar{\theta}_{\mu} \rho_t + \sum_{\mu'} \bar{\eta}_{\mu, \mu'} \mathbf{V}_{\mu'} \rho_t \mathbf{V}_{\mu'}^{\dagger}}{\bar{\theta}_{\mu} + \sum_{\mu'} \bar{\eta}_{\mu, \mu'} \text{Tr}(\mathbf{V}_{\mu'} \rho_t \mathbf{V}_{\mu'}^{\dagger})} - \rho_t \right) \left(dN_{\mu}(t) - \left(\bar{\theta}_{\mu} + \sum_{\mu'} \bar{\eta}_{\mu, \mu'} \text{Tr}(\mathbf{V}_{\mu'} \rho_t \mathbf{V}_{\mu'}^{\dagger}) \right) dt \right) \quad (4.27)$$

where the \mathbf{V}_{μ} 's are operators on Hilbert space \mathcal{H} , where the parameters $\bar{\theta}_{\mu}, \bar{\eta}_{\mu, \mu'} \geq 0$ with $\bar{\eta}_{\mu'} = \sum_{\mu} \bar{\eta}_{\mu, \mu'} \leq 1$, describe counting imperfections (slot-noise for $\bar{\theta}_{\mu}$, detection efficiencies and classical correlations for $\bar{\eta}_{\mu, \mu'}$). For each μ , $\left(\bar{\theta}_{\mu} + \sum_{\mu'} \bar{\eta}_{\mu, \mu'} \text{Tr}(\mathbf{V}_{\mu'} \rho_t \mathbf{V}_{\mu'}^{\dagger}) \right) dt$ is the probability to increment by one N_{μ} between t and $t + dt$, i.e. to have $dN_{\mu}(\tau)(t)$ equal to δ_t a Dirac at time t .

Take the following definition for \mathbf{M}_0

$$\mathbf{M}_0 = \mathbf{I} - \left(i\mathbf{H} + \frac{1}{2} \sum_{\mu} \mathbf{V}_{\mu}^{\dagger} \mathbf{V}_{\mu} \right) dt$$

and consider the following partial Kraus map:

$$\mathbf{K}_0(\rho) = \mathbf{M}_0 \rho \mathbf{M}_0^{\dagger} + \sum_{\mu} (1 - \bar{\eta}_{\mu}) \mathbf{V}_{\mu} \rho \mathbf{V}_{\mu}^{\dagger} dt.$$

The stochastic model (4.27) is similar to the discrete-time Markov process (3.26) where the discrete-time outcomes y_k is replaced by the counting increments $dN(t) = (dN_{\mu}(t))_{\mu}$. More precisely, the transition from ρ_t to ρ_{t+dt} is given by the following transition rules:

1. The transition corresponding to no-jump outcomes, i.e. $dN(t) = 0$ reads

$$\rho_{t+dt} = \frac{\mathbf{K}_0(\rho_t)}{\text{Tr}(\mathbf{K}_0(\rho_t))}$$

and is associated to the following probability law:

$$\mathbb{P} \left(dN(t) = 0 \mid \rho_t \right) = \left(1 - \left(\sum_{\mu} \bar{\theta}_{\mu} \right) dt \right) \text{Tr}(\mathbf{K}_0(\rho_t)).$$

2. The transition corresponding to outcomes with a single jump of label μ , i.e. $dN_{\mu}(t)$ being a Dirac at time t , reads

$$\rho_{t+dt} = \frac{\mathbf{K}_0(\tilde{\rho}_t)}{\text{Tr}(\mathbf{K}_0(\tilde{\rho}_t))} \quad \text{with} \quad \tilde{\rho}_t = \frac{\bar{\theta}_{\mu} \rho_t + \sum_{\mu'} \bar{\eta}_{\mu, \mu'} \mathbf{V}_{\mu'} \rho_t \mathbf{V}_{\mu'}^{\dagger}}{\text{Tr}(\bar{\theta}_{\mu} \rho_t + \sum_{\mu'} \bar{\eta}_{\mu, \mu'} \mathbf{V}_{\mu'} \rho_t \mathbf{V}_{\mu'}^{\dagger})}$$

and is associated to the following probability law:

$$\mathbb{P} \left(dN'_{\mu}(t) = \delta_{\mu, \mu'} \delta_t \mid \rho_t \right) = dt \text{Tr} \left(\bar{\theta}_{\mu} \rho_t + \sum_{\mu'} \bar{\eta}_{\mu, \mu'} \mathbf{V}_{\mu'} \rho_t \mathbf{V}_{\mu'}^{\dagger} \right)$$

3. The probability to have at least two jumps, i.e. $dN_\mu(t) = dN_{\mu'}(t) = \delta_t$ for some $\mu \neq \mu'$, is an $O(dt^2)$ and thus negligible.

Notice that

$$\mathbb{P}\left(dN(t) = 0 \mid \rho_t\right) + \mathbb{P}\left(dN'_\mu(t) = \delta_{\mu,\mu'}\delta_t \mid \rho_t\right) = 1 + O(dt^2).$$

Standard computations show that such time discretization schemes converge in law to the continuous-time process (4.27) when dt tends to 0.

4.5.3 Mixed diffusive/jump case

This subsection is mainly based on [54, 4]. Mixed diffusive/jump stochastic master equations can be considered. Additional Poisson counting processes $(N_\mu(t))$ are added in parallel to the Wiener processes $(W_{\nu,t})$.

$$\begin{aligned} d\rho_t = & \left(-i[\mathbf{H}, \rho_t] + \sum_{\nu} \mathbf{L}_{\nu} \rho_t \mathbf{L}_{\nu}^{\dagger} - \frac{1}{2}(\mathbf{L}_{\nu}^{\dagger} \mathbf{L}_{\nu} \rho_t + \rho_t \mathbf{L}_{\nu}^{\dagger} \mathbf{L}_{\nu}) \right) dt \\ & + \sum_{\nu} \sqrt{\eta_{\nu}} \left(\mathbf{L}_{\nu} \rho_t + \rho_t \mathbf{L}_{\nu}^{\dagger} - \text{Tr}\left((\mathbf{L}_{\nu} + \mathbf{L}_{\nu}^{\dagger})\rho_t\right) \rho_t \right) dW_{\nu,t} \\ & + \left(\sum_{\mu} \mathbf{V}_{\mu} \rho_t \mathbf{V}_{\mu}^{\dagger} - \frac{1}{2}(\mathbf{V}_{\mu}^{\dagger} \mathbf{V}_{\mu} \rho_t + \rho_t \mathbf{V}_{\mu}^{\dagger} \mathbf{V}_{\mu}) \right) dt \\ & + \sum_{\mu} \left(\frac{\bar{\theta}_{\mu} \rho_t + \sum_{\mu'} \bar{\eta}_{\mu,\mu'} \mathbf{V}_{\mu'} \rho_t \mathbf{V}_{\mu'}^{\dagger}}{\bar{\theta}_{\mu} + \sum_{\mu'} \bar{\eta}_{\mu,\mu'} \text{Tr}\left(\mathbf{V}_{\mu'} \rho_t \mathbf{V}_{\mu'}^{\dagger}\right)} - \rho_t \right) \left(dN_{\mu}(t) - \left(\bar{\theta}_{\mu} + \sum_{\mu'} \bar{\eta}_{\mu,\mu'} \text{Tr}\left(\mathbf{V}_{\mu'} \rho_t \mathbf{V}_{\mu'}^{\dagger}\right) \right) dt \right) \end{aligned} \quad (4.28)$$

where the \mathbf{V}_{μ} 's are operators on Hilbert space \mathcal{H} , where the additional parameters $\bar{\theta}_{\mu}, \bar{\eta}_{\mu,\mu'} \geq 0$ with $\bar{\eta}_{\mu'} = \sum_{\mu} \bar{\eta}_{\mu,\mu'} \leq 1$, describe counting imperfections. For each μ , $\left(\bar{\theta}_{\mu} + \sum_{\mu'} \bar{\eta}_{\mu,\mu'} \text{Tr}\left(\mathbf{V}_{\mu'} \rho_t \mathbf{V}_{\mu'}^{\dagger}\right) \right) dt$ is the probability to increment by one N_{μ} between t and $t + dt$.

For any vector $\xi = (\xi_{\nu})$, take the following definition for M_{ξ}

$$M_{\xi} = I - \left(i\mathbf{H} + \frac{1}{2} \sum_{\nu} \mathbf{L}_{\nu}^{\dagger} \mathbf{L}_{\nu} + \frac{1}{2} \sum_{\mu} \mathbf{V}_{\mu}^{\dagger} \mathbf{V}_{\mu} \right) dt + \sum_{\nu} \sqrt{\eta_{\nu}} \xi_{\nu} \mathbf{L}_{\nu}$$

and consider the following partial Kraus map depending on ξ :

$$\mathbf{K}_{\xi}(\rho) = M_{\xi} \rho M_{\xi}^{\dagger} + \sum_{\nu} (1 - \eta_{\nu}) \mathbf{L}_{\nu} \rho \mathbf{L}_{\nu}^{\dagger} dt + \sum_{\mu} (1 - \bar{\eta}_{\mu}) \mathbf{V}_{\mu} \rho \mathbf{V}_{\mu}^{\dagger} dt.$$

The stochastic model (4.28) is similar to the discrete-time Markov process (3.26) where the discrete-time outcomes y_k is replaced by the continuous-time outcomes $(dy_t, dN(t))$. More precisely, the transition from ρ_t to ρ_{t+dt} is given by the following transition rules:

1. The transition corresponding to no-jump outcomes $(dy_t, dN(t) = 0)$ reads

$$\rho_{t+dt} = \frac{\mathbf{K}_{dy_t}(\rho_t)}{\text{Tr}(\mathbf{K}_{dy_t}(\rho_t))}$$

and is associated to the following probability law:

$$\begin{aligned} \mathbb{P} \left(dy \in \prod_{\nu} [\xi_{\nu}, \xi_{\nu} + d\xi_{\nu}] \text{ and } dN(t) = 0 \middle/ \rho_t \right) \\ = \left(1 - \left(\sum_{\mu} \bar{\theta}_{\mu} \right) dt \right) \text{Tr} \left(\mathbf{K}_{\xi}(\rho_t) \right) \left(\prod_{\nu} e^{-\xi_{\nu}^2/2dt} \frac{d\xi_{\nu}}{\sqrt{2\pi dt}} \right) \end{aligned}$$

Since

$$\int_{\xi} \text{Tr} \left(\mathbf{K}_{\xi}(\rho_t) \right) \prod_{\nu} e^{-\xi_{\nu}^2/2dt} \frac{d\xi_{\nu}}{\sqrt{2\pi dt}} = 1 - \left(\bar{\eta}_{\mu} \text{Tr} \left(\mathbf{V}_{\mu} \rho_t \mathbf{V}_{\mu}^{\dagger} \right) \right) dt + O(dt^2)$$

we recover the usual no-jump probability, $1 - \left(\sum_{\mu} \bar{\theta}_{\mu} + \bar{\eta}_{\mu} \text{Tr} \left(\mathbf{V}_{\mu} \rho_t \mathbf{V}_{\mu}^{\dagger} \right) \right) dt$, up to $O(dt^2)$ terms.

2. The transition corresponding to outcomes with a single jump of label μ , $(dy_t, dN(t) = \delta_t(\delta_{\mu, \mu'}))_{\mu'}$, reads

$$\rho_{t+dt} = \frac{\mathbf{K}_{dy_t} \left(\bar{\theta}_{\mu} \rho_t + \sum_{\mu'} \bar{\eta}_{\mu, \mu'} \mathbf{V}_{\mu'} \rho_t \mathbf{V}_{\mu'}^{\dagger} \right)}{\text{Tr} \left(\mathbf{K}_{dy_t} \left(\bar{\theta}_{\mu} \rho_t + \sum_{\mu'} \bar{\eta}_{\mu, \mu'} \mathbf{V}_{\mu'} \rho_t \mathbf{V}_{\mu'}^{\dagger} \right) \right)}$$

and is associated to the following probability law:

$$\begin{aligned} \mathbb{P} \left(dy \in \prod_{\nu} [\xi_{\nu}, \xi_{\nu} + d\xi_{\nu}] \text{ and } dN(t) = (\delta_{\mu, \mu'})_{\mu'} \middle/ \rho_t \right) \\ = dt \text{Tr} \left(\mathbf{K}_{\xi} \left(\bar{\theta}_{\mu} \rho_t + \sum_{\mu'} \bar{\eta}_{\mu, \mu'} \mathbf{V}_{\mu'} \rho_t \mathbf{V}_{\mu'}^{\dagger} \right) \right) \left(\prod_{\nu} e^{-\xi_{\nu}^2/2dt} \frac{d\xi_{\nu}}{\sqrt{2\pi dt}} \right) \end{aligned}$$

By integration versus ξ , we recover, up to $O(dt^2)$ terms, the probability of jump μ : $\left(\bar{\theta}_{\mu} + \sum_{\mu'} \bar{\eta}_{\mu, \mu'} \text{Tr} \left(\mathbf{V}_{\mu'} \rho_{t+dt} \mathbf{V}_{\mu'}^{\dagger} \right) \right) dt$.

3. The probability to have at least two jumps, i.e. $dN_{\mu}(t) = dN_{\mu'}(t) = \delta_t$ for some $\mu \neq \mu'$, is an $O(dt^2)$ and thus negligible.

Standard computations show that such time discretization schemes converge in law to the continuous-time process (4.28) when dt tends to 0. They preserve the fact that $\rho \geq 0$ and can be used for Monte-Carlo simulations and quantum filtering.

4.6 QND measurement of a qubit and asymptotic behavior

In this section, we consider a continuous measurement protocol for a single qubit. The considered setup corresponds to the inverse of the photon box experiment. As illustrated in Figure 4.2, we consider the qubit to be fixed inside the cavity and interacting with the confined electromagnetic field. The cavity however is assumed to be not ideal and the confined field can leak out at a rate κ . This outgoing field is continuously measured through what is called a homodyne measurement process, corresponding to the measurement of a certain quadrature

$\mathbf{X}_\lambda = (e^{i\lambda}\mathbf{a}^\dagger + e^{-i\lambda}\mathbf{a})/2$ as physical observable. Assuming a dispersive coupling between the qubit and the cavity (see Section 1.3.1) and in the regime where the leakage rate κ is much stronger than the other dynamical time-scales, such as an eventual Rabi oscillation rate for the qubit, the cavity dynamics can be removed leading to a stochastic master equation for the qubit [34] (we will skip the details of this model reduction which includes some details that are out of the scope of these lectures).

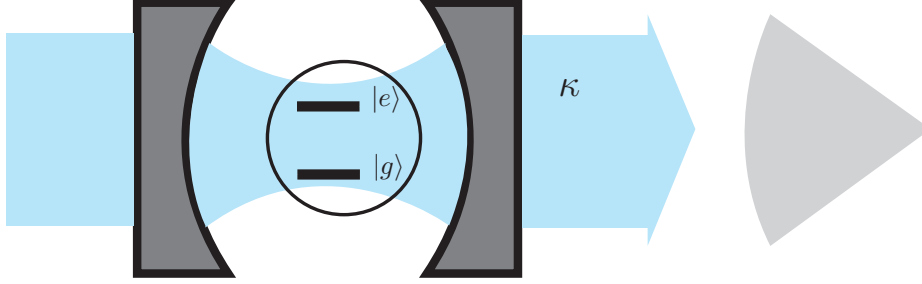

Figure 4.2: The cavity field interacts with the qubit and the cavity output gets measured providing information on the state of the qubit.

For a well-chosen measured quadrature \mathbf{X}_λ , this SME of the form (4.25) is given by

$$d\rho_t = -i[\mathbf{H}, \rho_t]dt + \frac{\Gamma_m}{4}(\sigma_z \rho_t \sigma_z - \rho_t)dt + \frac{\sqrt{\eta\Gamma_m}}{2}(\sigma_z \rho_t + \rho_t \sigma_z - 2\text{Tr}(\sigma_z \rho_t)\rho_t)dW_t, \quad (4.29)$$

where \mathbf{H} is the qubit's Hamiltonian, the only Lindblad operator \mathbf{L}_ν is given by $\sqrt{\Gamma_m}\sigma_z/2$, and $\eta \in [0, 1]$ represents the detector efficiency. The measured signal dy_t is given by

$$dy_t = dW_t + \sqrt{\eta\Gamma_m}\text{Tr}(\sigma_z \rho_t)dt. \quad (4.30)$$

Let us consider here the uncontrolled case where the Hamiltonian \mathbf{H} is simply given by $\omega_{eg}\sigma_z/2$. Following the arguments of the previous section, the above SME correspond to a Markov process with the Kraus operators

$$\mathbf{M}_{dy_t} = \mathbf{I} - (i\frac{\omega_{eg}}{2}\sigma_z + \frac{\Gamma_m}{8}\mathbf{I})dt + \frac{\sqrt{\eta\Gamma_m}}{2}\sigma_z dy_t \quad \text{and} \quad \sqrt{(1-\eta)dt}\mathbf{L} = \frac{\sqrt{(1-\eta)\Gamma_m}dt}{2}\sigma_z.$$

Noting that the above operators commute with σ_z , following the definition of Section 3.1.3, we have a quantum non-demolition (QND) measurement of the observable σ_z . Here, we study, similarly to the Section 3.2.5, the asymptotic behavior of the open-loop system undergoing the above continuous measurement process.

Theorem 4. *Consider the SME (4.29) with $\mathbf{H} = \omega_{eg}\sigma_z/2$ and $\eta > 0$. For any initial density matrix ρ_0 , the solution ρ_t converges almost surely as $t \rightarrow \infty$ to one of the states $|g\rangle\langle g|$ or $|e\rangle\langle e|$. Furthermore the probability of convergence to $|g\rangle\langle g|$ (respectively $|e\rangle\langle e|$) is given by $p_g = \text{Tr}(|g\rangle\langle g|\rho_0)$ (respectively $\text{Tr}(|e\rangle\langle e|\rho_0)$).*

Proof. We consider the Lyapunov function

$$V(\rho) = \sqrt{1 - \text{Tr}(\sigma_z \rho)^2}.$$

Ito computations of $dV_t \triangleq V(\rho_{t+dt}) - V(\rho_t)$ is based on a second order expansion of $f(z + dz)$ around z where $z = \text{Tr}(\sigma_z \rho)_t$, $f(z) = \sqrt{1 - z^2}$ and $dz = \text{Tr}(\sigma_z \rho)_{t+dt} - \text{Tr}(\sigma_z \rho)_t$. By linearity, $dz = \text{Tr}(\sigma_z d\rho_t)$ with $d\rho_t$ given by (4.29), yields directly to

$$dz = \sqrt{\eta\Gamma_m}(1 - z^2)dW_t.$$

Since $\frac{df}{dz} = \frac{-1}{\sqrt{1-z^2}}$ and $\frac{d^2f}{dz^2} = \frac{-1}{(1-z^2)\sqrt{1-z^2}}$, the second order expansion of $f(z + dz)$ around z reads

$$f(z + dz) = f(z) - \frac{dz}{\sqrt{1 - z^2}} - \frac{dz^2}{2(1 - z^2)\sqrt{1 - z^2}} + O(|dz|^3).$$

With Ito rules $dz^2 = \eta\Gamma_m(1 - z^2)^2dt$. Thus

$$dV_t \triangleq V(\rho_{t+dt}) - V(\rho_t) = -\sqrt{\eta\Gamma_m}\sqrt{1 - z^2}dW_t - \frac{\eta\Gamma_m}{2}\sqrt{1 - z^2}dt.$$

Thus $\mathbb{E}(dV_t | \rho_t) = -\frac{\eta\Gamma_m}{2}\sqrt{1 - z^2}dt = -\frac{\eta\Gamma_m}{2}V_tdt$ By linearity we have

$$\frac{d}{dt}\mathbb{E}(V(\rho_t) | \rho_0) = -\frac{\eta\Gamma_m}{2}\mathbb{E}(V(\rho_t) | \rho_0).$$

and thus $\mathbb{E}(V(\rho_t) | \rho_0) = e^{-\frac{\eta\Gamma_m}{2}t}V(\rho_0)$ converges exponentially to 0 at rate $\frac{\eta\Gamma_m}{2}$.

By Theorem 5 of Appendix F, the limit $V(\rho_t)$ as $t \rightarrow \infty$ exists with probability one (as a supermartingale bounded from below) and its exponential decay to 0 implies that $V(\rho_t) \rightarrow 0$ almost surely. But the only states ρ satisfying $V(\rho) = 0$ are $\rho = |g\rangle\langle g|$ or $\rho = |e\rangle\langle e|$.

We can finish the proof by noting that $\text{Tr}(\sigma_z \rho_t)$ is a martingale. Therefore using a similar argument to Theorem 2 of Section 3.2.5, the probability of convergence to $|g\rangle\langle g|$ (respectively $|e\rangle\langle e|$) is given by $p_g = \text{Tr}(|g\rangle\langle g|\rho_0)$ (respectively $\text{Tr}(|e\rangle\langle e|\rho_0)$). \square

The above theorem implies that the continuous QND measurement can be seen as a non-deterministic preparation protocol for the states $|g\rangle\langle g|$ and $|e\rangle\langle e|$. Similarly to the Section 3.2.6, this preparation can be rendered deterministic by adding an appropriate feedback control. Indeed, it has been proven in [65] that, a controlled Hamiltonian

$$\mathbf{H} = \frac{\omega_{eg}}{2}\sigma_z + \frac{u}{2}\sigma_x,$$

with the feedback law

$$u(\rho) = -\alpha \text{Tr}(i[\sigma_x, \rho]\rho_{\text{tag}}) + \beta(1 - \text{Tr}(\rho\rho_{\text{tag}})), \quad \alpha, \beta > 0 \quad \text{and} \quad \beta^2 < 8\alpha\eta,$$

globally stabilizes the target state $\rho_{\text{tag}} = |g\rangle\langle g|$ or $|e\rangle\langle e|$.

See e.g. [48, 44, 45, 20, 21] for other stabilization scheme attached to similar and more general QND dispersive measurement cases.

Appendix A

Basic Quantum notions

All the objects, notions and operators described in this section are mathematically well-defined when the wave functions Hilbert space is of finite dimensions. In the case of infinite dimensional Hilbert space, one has to be aware that these objects, notions and operators might also be defined in principle but one needs to explore the mathematical justifications depending strongly on the specific physical system under study (involving in particular its spectral decomposition). For clarity sake, we consider here only the finite dimensional case even if some constructions and objects (such as tensor product) admit a straightforward extension to infinite dimensional Hilbert spaces.

A.1 Bra, Ket and operators

We just recall here some basic notions of quantum mechanics. We refer to the excellent course [26] where these notions are explained in details. Bra $\langle \bullet |$ and Ket $|\bullet\rangle$ are co-vector and vector. The quantum state is described by the ket $|\psi\rangle$ an element of norm one and belonging to a Hilbert space \mathcal{H} . The quantum state is also called (probability amplitude) wave function. The Hermitian conjugate of a Ket is a Bra: $\langle\psi| = |\psi\rangle^\dagger$. The Hermitian product between two kets (vectors, i.e. elements of \mathcal{H}), $|\psi\rangle$ and $|\phi\rangle$ is denoted by

$$\langle\psi| \cdot |\phi\rangle = \langle\psi|\phi\rangle = \langle\phi|\psi\rangle^* \in \mathbb{C}$$

where $*$ stands for complex conjugate. If we consider a Hilbert basis of \mathcal{H} , denoted by $|n\rangle$, $n = 1, \dots, \dim(\mathcal{H})$, we have

$$\begin{aligned} |\psi\rangle &= \sum_n \psi_n |n\rangle, & \forall n, \langle n|\psi\rangle &= \psi_n \in \mathbb{C} \\ \langle\psi|\psi\rangle &= \sum_n |\psi_n|^2 = 1 \\ |\phi\rangle &= \sum_n \phi_n |n\rangle, & \forall n, \langle n|\phi\rangle &= \phi_n \in \mathbb{C} \\ \langle\phi|\phi\rangle &= \sum_n |\phi_n|^2 = 1 \\ \langle\psi|\phi\rangle &= \sum_n \psi_n^* \phi_n \end{aligned}$$

since for all m, n , $\langle m|n\rangle = \delta_{m,n}$.

Any linear operator \mathbf{M} from \mathcal{H} into \mathcal{H} reads, in the orthonormal basis ($|n\rangle$),

$$\mathbf{M} = \sum_{m,n} M_{m,n} |m\rangle\langle n|, \quad M_{m,n} \in \mathbb{C}$$

where $M_{m,n} = \langle m|\mathbf{M}|n\rangle$ is the Hermitian product between $|m\rangle$ and $\mathbf{M}|n\rangle$. The operator \mathbf{M} is Hermitian when $\mathbf{M} = \mathbf{M}^\dagger$, i.e. $M_{m,n} = M_{n,m}^*$. The orthogonal projector \mathbf{P} on a Hilbert subspace \mathcal{H}_0 of \mathcal{H} is a Hermitian operator defined by the relation

$$\mathbf{P} = \sum_k |\phi_k\rangle\langle\phi_k|$$

where $|\phi_k\rangle_{k \in \{1, \dots, \dim(\mathcal{H}_0)\}}$ is any orthonormal basis of \mathcal{H}_0 .

The operator \mathbf{U} is unitary when $\mathbf{U}^{-1} = \mathbf{U}^\dagger$. Any operator $\mathbf{U} = \exp(i\mathbf{H})$ is unitary as soon as \mathbf{H} is Hermitian. We recall that

$$\exp(\mathbf{A}) = \sum_{k=0}^{+\infty} \frac{\mathbf{A}^k}{k!}$$

for any operator \mathbf{A} .

Take a Hermitian operator \mathbf{M} and consider its spectral decomposition

$$\mathbf{M} = \sum_{\nu} \lambda_{\nu} \mathbf{P}_{\nu}$$

where the λ_{ν} 's are the eigenvalues of \mathbf{M} ($\lambda_{\nu} \in \mathbb{R}$) and \mathbf{P}_{ν} the orthogonal projector on the eigenspace associated to λ_{ν} . By construction we have $\mathbf{I} = \sum_{\nu} \mathbf{P}_{\nu}$ where \mathbf{I} is the identity operator. For any function $f : \mathbb{R} \mapsto \mathbb{R}$ we can define $f(\mathbf{M})$ by

$$f(\mathbf{M}) = \sum_{\nu} f(\lambda_{\nu}) \mathbf{P}_{\nu}.$$

Thus \mathbf{M} and $f(\mathbf{M})$ commute and the image by f of the \mathbf{M} -spectrum is the spectrum of $f(\mathbf{M})$. This definition of $f(\mathbf{M})$ is just a more intrinsic formulation of the usual construction based $\mathbf{M} = \mathbf{U}\mathbf{\Delta}\mathbf{U}^\dagger$ with \mathbf{U} unitary and $\mathbf{\Delta}$ diagonal: $f(\mathbf{M}) = \mathbf{U}f(\mathbf{\Delta})\mathbf{U}^\dagger$ with $f(\mathbf{\Delta})$ the diagonal matrix obtained by taking the image via f of the scalar elements forming the diagonal matrix $\mathbf{\Delta}$.

A.2 Schrödinger equation

The dynamics of a the state $|\psi\rangle$ of a quantum system living in the Hilbert space \mathcal{H} is described by a Schrödinger equation:

$$i \frac{d}{dt} |\psi\rangle = \mathbf{H}(t) |\psi\rangle \quad (\text{A.1})$$

where $\mathbf{H}(t)$ is a time-varying Hermitian operator called the Hamiltonian. Here \hbar is set to 1 and thus $\mathbf{H}(t)$ has the dimension of a frequency.

The evolution of $|\psi\rangle$ is unitary: if $|\psi\rangle$ and $|\phi\rangle$ are solutions of the same Schrödinger equation (A.1) then $\langle\psi|\phi\rangle_t$ is constant and equal to the initial value $\langle\psi|\phi\rangle_0$. This means

that we can set $|\psi\rangle_t = \mathbf{U}_t|\psi\rangle_0$, for any solution of (A.1) starting from $|\psi\rangle_0$, where the time-dependent unitary operator \mathbf{U}_t , also the *propagator*, is solution of

$$i\frac{d}{dt}\mathbf{U}_t = \mathbf{H}(t)\mathbf{U}_t, \quad \mathbf{U}_0 = \mathbf{I}. \quad (\text{A.2})$$

Whenever the Hamiltonian \mathbf{H} is time-invariant, and once we have the spectral decomposition of \mathbf{H} , we have an explicit expression of \mathbf{U}_t . Indeed, taking

$$\mathbf{H} = \sum_{\nu} \omega_{\nu} \mathbf{P}_{\nu}$$

where for each ν , ω_{ν} is a different eigenvalue and \mathbf{P}_{ν} is the orthogonal projector onto the eigenspace associated to ω_{ν} , we have

$$\mathbf{U}_t = e^{-it\mathbf{H}} = \sum_{\nu} e^{-i\omega_{\nu}t} \mathbf{P}_{\nu}$$

and thus

$$|\psi\rangle_t = \sum_{\nu} e^{-i\omega_{\nu}t} \mathbf{P}_{\nu}|\psi\rangle_0.$$

Since, for any angle θ , $|\psi\rangle$ and $e^{i\theta}|\psi\rangle$ represent the same quantum state, the Hamiltonian $\mathbf{H}(t)$ is defined up to an addition of $\lambda\mathbf{I}$, where λ is any real quantity (homogeneous to an energy). More precisely, take any time varying global phase θ_t . Then $|\psi\rangle_t$ and $|\phi\rangle_t = e^{i\theta_t}|\psi\rangle_t$ represent the same quantum system. This means that if the evolution of $|\psi\rangle$ is driven by the Hamiltonian $\mathbf{H}(t)$, then the evolution of $|\phi\rangle$ is driven by $\mathbf{H}(t) + \dot{\theta}_t\mathbf{I}$: Hamiltonians $\mathbf{H}(t)$ and $\mathbf{H}(t) + \dot{\theta}_t\mathbf{I}$ are equivalent since they are attached to the same system. Thus, in specific examples, we can always choose the origin of the energy in order to get the simplest computation and formulae.

Exercice 17. Show that if we replace $\mathbf{H}(t)$ by $\mathbf{H}(t) - \frac{\text{Tr}(\mathbf{H}(t))}{\dim(\mathcal{H})}\mathbf{I}$ we ensure that $\det(\mathbf{U}_t) \equiv 1$.

A.3 Composite systems and tensor product

A composite system is made of several sub-systems. It is very important to realize that the state space (Hilbert space) of a composite system is not the Cartesian product of the state space of its subsystems, as it is the case for classical systems. It is their tensor product. This difference is essential.

Take a composite system of Hilbert space \mathcal{H} made of two sub-systems with Hilbert spaces \mathcal{H}_1 and \mathcal{H}_2 . Then $\mathcal{H} = \mathcal{H}_1 \otimes \mathcal{H}_2$ and $\dim(\mathcal{H}) = \dim(\mathcal{H}_1)\dim(\mathcal{H}_2)$. From Hilbert basis $(|n_1\rangle)_{n_1 \in \{1, \dots, \dim(\mathcal{H}_1)\}}$ of \mathcal{H}_1 and $(|n_2\rangle)_{n_2 \in \{1, \dots, \dim(\mathcal{H}_2)\}}$ of \mathcal{H}_2 , we get a Hilbert basis of \mathcal{H} ,

$$\begin{aligned} (|n_1, n_2\rangle) \quad & n_1 \in \{1, \dots, \dim(\mathcal{H}_1)\} \\ & n_2 \in \{1, \dots, \dim(\mathcal{H}_2)\} \end{aligned}$$

where $|n_1, n_2\rangle$ is used to denote $|n_1\rangle \otimes |n_2\rangle$. $\mathcal{H} = \mathcal{H}_1 \otimes \mathcal{H}_2$ contains all the tensor products $|\psi_1\rangle \otimes |\psi_2\rangle$ of elements $|\psi_1\rangle \in \mathcal{H}_1$ and $|\psi_2\rangle \in \mathcal{H}_2$. But it contains much more elements that are not tensor products of elements of \mathcal{H}_1 and \mathcal{H}_2

Exercise 18. Prove that

$$|\psi\rangle = |1, 1\rangle + |2, 2\rangle$$

cannot be expressed as a tensor product.

Take $|\psi\rangle, |\phi\rangle \in \mathcal{H}$. Then we have

$$\begin{aligned} |\psi\rangle &= \sum_{n_1, n_2} \psi_{n_1, n_2} |n_1, n_2\rangle, & \langle n_1, n_2 | \psi \rangle &= \psi_{n_1, n_2} \in \mathbb{C} \\ |\phi\rangle &= \sum_{n_1, n_2} \phi_{n_1, n_2} |n_1, n_2\rangle, & \langle n_1, n_2 | \phi \rangle &= \phi_{n_1, n_2} \in \mathbb{C} \\ \langle \psi | \phi \rangle &= \sum_{n_1, n_2} \psi_{n_1, n_2}^* \phi_{n_1, n_2}. \end{aligned}$$

Exercise 19. Prove from the above relationships that if $|\psi\rangle = |\psi_1\rangle \otimes |\psi_2\rangle$ and $|\phi\rangle = |\phi_1\rangle \otimes |\phi_2\rangle$ with $|\psi_1\rangle, |\phi_1\rangle \in \mathcal{H}_1$ and $|\psi_2\rangle, |\phi_2\rangle \in \mathcal{H}_2$, then $\langle \psi | \phi \rangle = \langle \psi_1 | \phi_1 \rangle \langle \psi_2 | \phi_2 \rangle$.

Consider M_1 a linear operator on \mathcal{H}_1 and M_2 a linear operator on \mathcal{H}_2 . The tensor product $M_1 \otimes M_2$ defines a linear operator on \mathcal{H} via the following relationships:

$$\begin{aligned} |\psi\rangle &= \sum_{n_1, n_2} \psi_{n_1, n_2} |n_1, n_2\rangle, & \langle n_1, n_2 | \psi \rangle &= \psi_{n_1, n_2} \in \mathbb{C} \\ M_1 \otimes M_2 |\psi\rangle &= \sum_{n_1, n_2} \psi_{n_1, n_2} M_1 |n_1\rangle \otimes M_2 |n_2\rangle. \end{aligned}$$

Thus when $|\psi\rangle = |\psi_1\rangle \otimes |\psi_2\rangle$, then we have always

$$M_1 \otimes M_2 |\psi\rangle = M_1 |\psi_1\rangle \otimes M_2 |\psi_2\rangle.$$

There are many operators on \mathcal{H} that are not tensor product of operators on \mathcal{H}_1 and \mathcal{H}_2 .

Exercise 20. Show that the linear operator (I_1 and I_2 are the identity operator of \mathcal{H}_1 and \mathcal{H}_2 respectively)

$$(|1\rangle\langle 2| + |2\rangle\langle 1|) \otimes I_2 + I_1 \otimes (|1\rangle\langle 2| + |2\rangle\langle 1|)$$

is not a tensor product $M_1 \otimes M_2$ (hint: consider the image of $|1, 1\rangle$).

If U_1 and U_2 are unitary operators on \mathcal{H}_1 and \mathcal{H}_2 , then $U_1 \otimes U_2$ is also unitary and

$$(U_1 \otimes U_2)^{-1} = U_1^{-1} \otimes U_2^{-1} = U_1^\dagger \otimes U_2^\dagger = (U_1 \otimes U_2)^\dagger.$$

For any operators A_1 and A_2 on \mathcal{H}_1 and \mathcal{H}_2 , we have¹

$$\exp(A_1 \otimes I_2 + I_1 \otimes A_2) = \exp(A_1) \otimes \exp(A_2)$$

This results from the fact that $A_1 \otimes I_2$ and $I_1 \otimes A_2$ commute:

$$\exp(A_1 \otimes I_2 + I_1 \otimes A_2) = \exp(A_1 \otimes I_2) \exp(I_1 \otimes A_2).$$

Since $\exp(A_1 \otimes I_2) = \exp(A_1) \otimes I_2$ and $\exp(I_1 \otimes A_2) = I_1 \otimes \exp(A_2)$, we get

$$\exp(A_1 \otimes I_2 + I_1 \otimes A_2) = (\exp(A_1) \otimes I_2)(I_1 \otimes \exp(A_2)) = \exp(A_1) \otimes \exp(A_2).$$

¹Notice that in general $\exp(A_1 \otimes A_2) \neq \exp(A_1) \otimes \exp(A_2)$.

This computation explains the shortcut notations of $\mathbf{A}_1 + \mathbf{A}_2$ instead of $\mathbf{A}_1 \otimes \mathbf{I}_2 + \mathbf{I}_1 \otimes \mathbf{A}_2$ and the rule

$$\exp(\mathbf{A}_1 + \mathbf{A}_2) = \exp(\mathbf{A}_1) \exp(\mathbf{A}_2) = \exp(\mathbf{A}_2) \exp(\mathbf{A}_1)$$

that is free from ambiguity since operators \mathbf{A}_1 and \mathbf{A}_2 act on different spaces and necessarily commute.

Take a composite system living on the tensor product $\mathcal{H} \otimes \mathcal{E}$ where \mathcal{E} is another Hilbert space (typically the Hilbert space of the environment). The partial trace versus \mathcal{E} is a super-operator that to any operator \mathbf{M} on $\mathcal{H} \otimes \mathcal{E}$ associates an operator on \mathcal{H} , denoted by $\text{Tr}_{\mathcal{E}}(\mathbf{M})$. It is defined as follows. Take any orthonormal basis of \mathcal{H} , $(|n\rangle)_n$, and of \mathcal{E} , $(|\nu\rangle)_{\nu}$. For the operator \mathbf{M} defined by

$$\mathbf{M} = \sum_{n_1, \nu_1, n_2, \nu_2} \mathbf{M}_{n_1, \nu_1, n_2, \nu_2} |n_1, \nu_1\rangle \langle n_2, \nu_2|$$

its partial trace is given by

$$\text{Tr}_{\mathcal{E}}(\mathbf{M}) = \sum_{n_1, n_2, \nu} \mathbf{M}_{n_1, \nu, n_2, \nu} |n_1\rangle \langle n_2|.$$

Exercise 21. Show that this definition is independent of the choice of the orthonormal frames $(|n\rangle)_n$ in \mathcal{H} and $(|\nu\rangle)_{\nu}$ in \mathcal{E} .

Partial traces are related to usual traces:

$$\text{Tr}(\mathbf{M}) = \text{Tr}_{\mathcal{H}}(\text{Tr}_{\mathcal{E}}(\mathbf{M})) = \text{Tr}_{\mathcal{E}}(\text{Tr}_{\mathcal{H}}(\mathbf{M})).$$

We also have $\text{Tr}_{\mathcal{E}}(\mathbf{M}^{\dagger}) = (\text{Tr}_{\mathcal{E}}(\mathbf{M}))^{\dagger}$ and if $\mathbf{M} = \mathbf{A} \otimes \mathbf{B}$ then $\text{Tr}_{\mathcal{E}}(\mathbf{A} \otimes \mathbf{B}) = \text{Tr}(\mathbf{B}) \mathbf{A}$. Finally, for any operators \mathbf{M} on $\mathcal{H} \times \mathcal{E}$ and \mathbf{A} on \mathcal{H} , we have:

$$\text{Tr}(\text{Tr}_{\mathcal{E}}(\mathbf{M}) \mathbf{A}) = \text{Tr}(\mathbf{M}(\mathbf{A} \otimes \mathbf{I})).$$

A.4 Density operator

Such a formulation of quantum state is relevant when the wave function $|\Psi\rangle$ is defined on a tensor product $\mathcal{H} \otimes \mathcal{E}$ and we do not have access to \mathcal{E} (we are only interested in the subsystem living on \mathcal{H}). The density operator is then defined by a partial trace versus \mathcal{E} of the projector $|\Psi\rangle\langle\Psi|$:

$$\rho = \text{Tr}_{\mathcal{E}}(|\Psi\rangle\langle\Psi|).$$

The density operator is always Hermitian, semi-definite positive and with $\text{Tr}(\rho) = 1$. When additionally $\text{Tr}(\rho^2) = 1$, ρ is a projector onto a pure state $\rho = |\psi\rangle\langle\psi|$, one says briefly that ρ is a pure state.

Exercise 22. Take $|\Psi\rangle \in \mathcal{H} \otimes \mathcal{E}$ and assume that $\rho = \text{Tr}_{\mathcal{E}}(|\Psi\rangle\langle\Psi|)$ is a pure state, $\rho = |\psi\rangle\langle\psi|$ with $|\psi\rangle \in \mathcal{H}$. Then prove that $|\Psi\rangle = |\psi\rangle \otimes |\xi\rangle$ with $|\xi\rangle \in \mathcal{E}$.

If the quantum state $|\Psi\rangle$ admits a time evolution (A.1) with Hamiltonian $\mathbf{H} \otimes \mathbf{I}$, then the time evolution of the density operator ρ is given by the Liouville equations

$$i \frac{d}{dt} \rho = [\mathbf{H}, \rho] = (\mathbf{H} \rho - \rho \mathbf{H})$$

where \mathbf{H} may depend on t . Thus, the spectrum of ρ is invariant since ρ_t and ρ_0 are related by $\rho_t \mathbf{U}_t = \mathbf{U}_t \rho_0$ where \mathbf{U}_t is the propagator defined in (A.2). In particular, for any integer exponent m , $\text{Tr}((\rho_t)^m) = \text{Tr}((\rho_0)^m)$.

A.5 Observables and measurement

To each measurement process is attached a Hermitian operator \mathbf{M} on \mathcal{H} , called also a physical observable. Take its spectral decomposition

$$\mathbf{M} = \sum_{\nu} \lambda_{\nu} \mathbf{P}_{\nu}$$

where λ_{ν} 's are the eigenvalues of M ($\lambda_{\nu} \in \mathbb{R}$) and \mathbf{P}_{ν} the orthogonal projector on the eigenspace associated to λ_{ν} . In this spectral decomposition $\lambda_{\nu_1} \neq \lambda_{\nu_2}$ as soon as $\nu_1 \neq \nu_2$: each ν corresponds to a different value of the measurement process.

Take now $|\psi\rangle \in \mathcal{H}$. Then the measurement process attached to \mathbf{M} yields to λ_{ν} with probability $\langle\psi|\mathbf{P}_{\nu}|\psi\rangle$. Indeed, assume that we have, at our disposal, a large number n of identical systems with the same quantum state $|\psi\rangle$. For each system, we measure \mathbf{M} and obtain the value $\lambda_{\nu_1}, \dots, \lambda_{\nu_n}$. Set

$$n_{\nu} = \#\{\lambda_{\mu} \mid \lambda_{\mu} = \lambda_{\nu}\}.$$

Then for n large and each ν , we have $\frac{n_{\nu}}{n} \approx \langle\psi|\mathbf{P}_{\nu}|\psi\rangle$. This is consistent with the fact that, independently of $|\psi\rangle$, we have $\sum_{\nu} n_{\nu} = n$ and $\sum_{\nu} \mathbf{P}_{\nu} = I$. Notice also that the arithmetic mean value of the n measures is approximatively $\langle\psi|\mathbf{M}|\psi\rangle$ since we have, for n large,

$$\frac{\sum_{k=1}^n \lambda_{\nu_k}}{n} = \frac{\sum_{\nu} n_{\nu} \lambda_{\nu}}{n} \approx \sum_{\nu} \langle\psi|\mathbf{P}_{\nu}|\psi\rangle \lambda_{\nu} = \langle\psi|\mathbf{M}|\psi\rangle.$$

Moreover just after the k 'th measurement that yields λ_{ν_k} , the state $|\psi\rangle$ is drastically changed to $\frac{1}{\langle\psi|\mathbf{P}_{\nu}|\psi\rangle} \mathbf{P}_{\nu_k} |\psi\rangle$. This is the famous "collapse of the wave packet" associated to any measurement process and on which is based the Copenhagen interpretation of the wave function $|\psi\rangle$.

Example 1. *The measurement of $\sigma_z = -|g\rangle\langle g| + |e\rangle\langle e|$ for the first qubit of a 2-qubit system corresponds to the operator (observable) $\mathbf{M} = \sigma_z \otimes I$. On the 2-qubit system*

$$|\psi\rangle = \psi_{gg}|g, g\rangle + \psi_{ge}|g, e\rangle + \psi_{eg}|e, g\rangle + \psi_{ee}|e, e\rangle$$

the measurement of σ_z for the first qubit, gives, in average,

$$\langle\psi|\mathbf{M}|\psi\rangle = -(|\psi_{gg}|^2 + |\psi_{ge}|^2) + (|\psi_{eg}|^2 + |\psi_{ee}|^2)$$

i.e., gives either -1 with a probability $|\psi_{gg}|^2 + |\psi_{ge}|^2$, or $+1$ with a probability $|\psi_{eg}|^2 + |\psi_{ee}|^2$. If, just before the measurement of σ_z on the first qubit, the quantum state is

$$|\psi\rangle = \psi_{gg}|g, g\rangle + \psi_{ge}|g, e\rangle + \psi_{eg}|e, g\rangle + \psi_{ee}|e, e\rangle,$$

then, just after the measurement, the quantum state changes to

- either $\frac{\psi_{gg}|g, g\rangle + \psi_{ge}|g, e\rangle}{\sqrt{|\psi_{gg}|^2 + |\psi_{ge}|^2}} = |g\rangle \otimes \left(\frac{\psi_{gg}|g\rangle + \psi_{ge}|e\rangle}{\sqrt{|\psi_{gg}|^2 + |\psi_{ge}|^2}} \right)$ if the measurement outcome is -1 ,
- or $\frac{\psi_{eg}|e, g\rangle + \psi_{ee}|e, e\rangle}{\sqrt{|\psi_{eg}|^2 + |\psi_{ee}|^2}} = |e\rangle \otimes \left(\frac{\psi_{eg}|g\rangle + \psi_{ee}|e\rangle}{\sqrt{|\psi_{eg}|^2 + |\psi_{ee}|^2}} \right)$ if the measurement outcome is $+1$

For systems with quantum states described by a density operator ρ , the measurement process attached to the Hermitian operator M with spectral decomposition $M = \sum_{\nu} \lambda_{\nu} P_{\nu}$ becomes:

- the probability to get λ_{ν} , as the measurement outcome, is $\text{Tr}(\rho P_{\nu})$ and just after this measurement ρ collapses to $\frac{1}{\text{Tr}(\rho P_{\nu})} P_{\nu} \rho P_{\nu}$ (notice that $\text{Tr}(\rho P_{\nu}) = \text{Tr}(P_{\nu} \rho P_{\nu})$ since $P_{\nu}^2 = P_{\nu}$).
- the average value of a large number of measurements of M on the same quantum state ρ is given by $\text{Tr}(\rho M)$.

A.6 Pauli Matrices

The Pauli matrices are 2×2 Hermitian matrices:

$$\sigma_x = |e\rangle\langle g| + |g\rangle\langle e|, \quad \sigma_y = -i|e\rangle\langle g| + i|g\rangle\langle e|, \quad \sigma_z = |e\rangle\langle e| - |g\rangle\langle g|$$

where $|g\rangle = \begin{pmatrix} 0 \\ 1 \end{pmatrix}$ and $|e\rangle = \begin{pmatrix} 1 \\ 0 \end{pmatrix}$ is the canonical Hilbert basis of \mathbb{C}^2 , the complex plane.

They satisfy the following relations (I denotes the 2×2 identity matrix here):

$$\sigma_x^2 = I, \quad \sigma_y^2 = I, \quad \sigma_z^2 = I, \quad \sigma_x \sigma_y = i\sigma_z, \quad \sigma_y \sigma_z = i\sigma_x, \quad \sigma_z \sigma_x = i\sigma_y.$$

For any angle $\theta \in \mathbb{R}$ we have

$$e^{i\theta\sigma_{\alpha}} = \cos\theta I + i\sin\theta\sigma_{\alpha}, \quad \text{for } \alpha = x, y, z.$$

Thus the solution of the Schrödinger equation ($\Omega \in \mathbb{R}$)

$$i \frac{d}{dt} |\psi\rangle = \frac{\Omega}{2} \sigma_z |\psi\rangle$$

is given by

$$|\psi\rangle_t = e^{-\frac{i\Omega t}{2} \sigma_z} |\psi\rangle_0 = \left(\cos\left(\frac{\Omega t}{2}\right) - i \sin\left(\frac{\Omega t}{2}\right) \sigma_z \right) |\psi\rangle_0.$$

For $\alpha, \beta = x, y, z$, $\alpha \neq \beta$ we have the useful formulas:

$$\sigma_{\alpha} e^{i\theta\sigma_{\beta}} = e^{-i\theta\sigma_{\beta}} \sigma_{\alpha}, \quad \left(e^{i\theta\sigma_{\alpha}} \right)^{-1} = \left(e^{i\theta\sigma_{\alpha}} \right)^{\dagger} = e^{-i\theta\sigma_{\alpha}}$$

and also

$$e^{-\frac{i\theta}{2} \sigma_{\alpha}} \sigma_{\beta} e^{\frac{i\theta}{2} \sigma_{\alpha}} = e^{-i\theta\sigma_{\alpha}} \sigma_{\beta} = \sigma_{\beta} e^{i\theta\sigma_{\alpha}}.$$

Take $\sigma = a\sigma_x + b\sigma_y + c\sigma_z$ with $a, b, c \in \mathbb{R}$ such that $a^2 + b^2 + c^2 = 1$. Then $\sigma^2 = 1$. Thus for any angle $\theta \in \mathbb{R}$, we have

$$e^{i\theta\sigma} = \cos\theta I + i\sin\theta \sigma.$$

Appendix B

Operator spaces

This summary is strongly inspired from chapter 4 of [62] where detailed justifications can be found. \mathcal{H} denotes a separable Hilbert space. We summarize the basic properties of the following spaces of linear operators on \mathcal{H} : finite rank operators $\mathcal{K}^f(\mathcal{H})$, trace-class operators $\mathcal{K}^1(\mathcal{H})$, Hilbert-Schmidt operators $\mathcal{K}^2(\mathcal{H})$, compact operators $\mathcal{K}^c(\mathcal{H})$ and bounded operators $\mathcal{B}(\mathcal{H})$. These operators spaces, $\mathcal{K}^f(\mathcal{H}) \subset \mathcal{K}^1(\mathcal{H}) \subset \mathcal{K}^2(\mathcal{H}) \subset \mathcal{K}^c(\mathcal{H}) \subset \mathcal{B}(\mathcal{H})$, are non-commutative analogue of the following usual spaces of complex-value series $(\lambda_k)_{k \geq 0}$:

- $\mathcal{K}^f(\mathcal{H})$ mimics series with a finite number of non zero terms.
- $\mathcal{K}^1(\mathcal{H})$ mimics absolutely converging series, $\sum_{k \geq 0} |\lambda_k| < +\infty$; the analogue of the l^1 norm is the trace-class norm.
- $\mathcal{K}^2(\mathcal{H})$ mimics l^2 series, $\sum_{k \geq 0} |\lambda_k|^2 < +\infty$; the analogue of the scalar product on l^2 is the Frobenius product.
- $\mathcal{K}^c(\mathcal{H})$ mimics series whose general term converges to zero: $\lim_{k \rightarrow +\infty} \lambda_k = 0$.
- $\mathcal{B}(\mathcal{H})$ mimics l^∞ series, i.e., bounded series; the analogue of the l^∞ norm becomes the sup norm on bounded operators.

Elements of \mathcal{H} are vectors denoted usually with the Ket notation $|\psi\rangle \in \mathcal{H}$. The Hermitian product between two Kets $|\psi\rangle$ and $|\phi\rangle$ is denoted by $\langle\psi|\phi\rangle = \langle\psi||\phi\rangle$ where $\langle\psi| = |\psi\rangle^\dagger$ is the Bra, the co-vector associated to $|\psi\rangle$, element of the dual \mathcal{H}^* of \mathcal{H} , and defining a continuous linear map: $\mathcal{H} \ni |\phi\rangle \mapsto \langle\psi|\phi\rangle \in \mathbb{C}$. The length of $|\psi\rangle$ is denoted by $\|\psi\| = \sqrt{\langle\psi|\psi\rangle}$.

$\mathcal{L}(\mathcal{H})$ denotes the vector space of linear operators from \mathcal{H} to \mathcal{H} . For $\mathbf{A} \in \mathcal{L}(\mathcal{H})$, \mathbf{A}^\dagger denotes its Hermitian conjugate, another element of $\mathcal{L}(\mathcal{H})$ defined by $\forall |\psi\rangle, |\phi\rangle \in \mathcal{H}$, $\langle\psi|(\mathbf{A}|\phi\rangle)\rangle = \langle(\mathbf{A}^\dagger|\psi\rangle)|\phi\rangle$.

The set of bounded operators on \mathcal{H} is denoted by $\mathcal{B}(\mathcal{H})$. The vector space $\mathcal{B}(\mathcal{H})$ equipped with the following sup norm

$$\|\mathbf{A}\| = \sup_{\substack{|\psi\rangle \in \mathcal{H} \\ \langle\psi|\psi\rangle = 1}} \sqrt{\langle\psi|\mathbf{A}^\dagger\mathbf{A}|\psi\rangle}$$

is a Banach space. Bounded operators of $\mathcal{L}(\mathcal{H})$ are continuous operators of $\mathcal{L}(\mathcal{H})$. An operator \mathbf{U} of $\mathcal{L}(\mathcal{H})$ is called unitary, if it is invertible and if $\mathbf{U}^{-1} = \mathbf{U}^\dagger$. Any unitary operator \mathbf{U} belongs to $\mathcal{B}(\mathcal{H})$.

Take two elements of \mathcal{H} , $|a\rangle$ and $|b\rangle$: they define a Ket-Bra operator $\mathbf{P}_{a,b} \in \mathcal{B}(\mathcal{H})$ via the following correspondence:

$$\forall |\psi\rangle \in \mathcal{H}, \mathbf{P}_{a,b}(|\psi\rangle) = (\langle b|\psi\rangle)|a\rangle.$$

Usual $\mathbf{P}_{a,b}$ is denoted by $|a\rangle\langle b|$ since $\mathbf{P}_{a,b}(|\psi\rangle) = |a\rangle\langle b|\psi\rangle$.

Exercise 23. Show that $\|\mathbf{P}_{a,b}\| = \frac{\sqrt{\langle a|a\rangle\langle b|b\rangle + |\langle a|b\rangle|}}{2}$

Let $|\psi\rangle$ be a unitary vector of \mathcal{H} ($\langle\psi|\psi\rangle = 1$). The orthogonal projector on the line spanned by $|\psi\rangle$, $\{z|\psi\rangle \mid z \in \mathbb{C}\}$ is the Ket-Bra operator $\mathbf{P}_{\psi,\psi} = |\psi\rangle\langle\psi|$. The orthogonal projector $\mathbf{P}_{\mathcal{H}_f}$ on a finite dimensional vector space \mathcal{H}_f of \mathcal{H} reads

$$\mathbf{P}_{\mathcal{H}_f} = \sum_{k=1}^N |a_k\rangle\langle a_k|$$

where $(|a_1\rangle, \dots, |a_N\rangle)$ is any ortho-normal basis of \mathcal{H}_f .

An element \mathbf{A} of $\mathcal{L}(\mathcal{H})$ is said to be finite rank, if and only if, it can be expressed as a finite sum of length N of Ket-Bra operators:

$$\mathbf{A} = \sum_{k=1}^N |a_k\rangle\langle b_k|$$

where $|a_k\rangle$ and $|b_k\rangle$ belong to \mathcal{H} . The linear sub-space of $\mathcal{L}(\mathcal{H})$ of finite rank operators of \mathcal{H} is noted by $\mathcal{K}^f(\mathcal{H})$. It is clear that $\mathcal{K}^f(\mathcal{H}) \subset \mathcal{B}(\mathcal{H})$. Moreover $\mathbf{A} \in \mathcal{L}(\mathcal{H})$ belongs to $\mathcal{K}^f(\mathcal{H})$ if and only if its range, the sub-vector space of \mathcal{H} denoted by $R(\mathbf{A}) = \{\mathbf{A}|\psi\rangle \mid |\psi\rangle \in \mathcal{H}\}$, is finite dimensional. The rank of \mathbf{A} is then the dimension of its range $R(\mathbf{A})$.

Exercise 24. Show that for $\mathbf{A} \in \mathcal{K}^f(\mathcal{H})$ with \mathcal{H} of infinite dimension, the kernel of \mathbf{A} , $\ker(\mathbf{A}) = \{|\psi\rangle \in \mathcal{H} \mid \mathbf{A}|\psi\rangle = 0\}$ is of infinite dimension.

An element \mathbf{A} of $\mathcal{L}(\mathcal{H})$ is said to be compact, if and only if, the image via \mathbf{A} of any bounded sub-set of \mathcal{H} admits a compact closure. The set of compact operators is denoted by $\mathcal{K}^c(\mathcal{H})$. Any compact operator is thus bounded, $\mathcal{K}^c(\mathcal{H}) \subset \mathcal{B}(\mathcal{H})$: it is a sub-vector space of $\mathcal{B}(\mathcal{H})$. The completion of $\mathcal{K}^f(\mathcal{H})$ with respect to the norm on $\mathcal{B}(\mathcal{H})$ is the set of compact operators $\mathcal{K}^c(\mathcal{H})$: by Hilbert theorem, any compact operator is the limit of finite rank operators for the sup norm on $\mathcal{B}(\mathcal{H})$. This implies that $\mathcal{K}^c(\mathcal{H})$ equipped with the sup norm inherited from $\mathcal{B}(\mathcal{H})$ is a Banach space.

Finally, any compact Hermitian operator \mathbf{A} admits a discrete real spectrum $(\lambda_k)_{k \in \mathbb{N}}$ with $\lim_{k \rightarrow +\infty} \lambda_k = 0$. To each λ_k we can associate a unitary Ket $|e_k\rangle$ such that $(|e_k\rangle)_{k \in \mathbb{N}}$ is an Hilbert basis of \mathcal{H} . Then we have

$$\mathbf{A} = \sum_{k \geq 0} \lambda_k |e_k\rangle\langle e_k|.$$

The above series is absolutely convergent in $\mathcal{B}(\mathcal{H})$ with the sup norm. In this decomposition, the λ_k 's are countered with their possible multiplicities. Another equivalent and more intrinsic decomposition (unitary invariance) where each λ_k are different, is as follows

$$\mathbf{A} = \sum_k \lambda_k \mathbf{P}_k$$

where \mathbf{P}_k is the orthogonal projector on the eigen-space associated to the eigenvalue λ_k .

Consider a non-negative Hermitian compact operator \mathbf{A} with eigenvalues $(\lambda_k)_{k \in \mathbb{N}}$ counted with their multiplicities ($\mathbf{A} = \sum_{k \geq 0} \lambda_k |e_k\rangle\langle e_k|$). Then $\lambda_k \geq 0$. \mathbf{A} is said trace class, if and only if, $\sum_{k \geq 0} \lambda_k < +\infty$. It is then simple to prove that $\sum_{k \geq 0} \lambda_k = \sum_{n \geq 0} \langle a_n | \mathbf{A} | a_n \rangle$ where $(|a_n\rangle)_{n \geq 0}$ is any orthonormal basis of \mathcal{H} . Consequently, $\sum_{k \geq 0} \lambda_k$ is denoted by $\text{Tr}(\mathbf{A})$.

More generally a compact operator \mathbf{A} is trace class, if and only if, $\text{Tr}(\sqrt{\mathbf{A}^\dagger \mathbf{A}}) < +\infty$. Since \mathbf{A} is compact, the non-negative Hermitian operator $\mathbf{A}^\dagger \mathbf{A}$ is also compact. Thus it admits a spectral decomposition $\mathbf{A}^\dagger \mathbf{A} = \sum_k \lambda_k \mathbf{P}_k$ where $\lambda_k \geq 0$. Then $\sqrt{\mathbf{A}^\dagger \mathbf{A}}$ is defined as $\sum_k \sqrt{\lambda_k} \mathbf{P}_k$: it is another non-negative Hermitian compact operator whose square coincides with $\mathbf{A}^\dagger \mathbf{A}$.

Exercice 25. Show that $\mathbf{A} \in \mathcal{K}^c(\mathcal{H})$ is trace-class if and only if $\Re(\mathbf{A}) = (\mathbf{A} + \mathbf{A}^\dagger)/2$ and $\Im(\mathbf{A}) = (\mathbf{A} - \mathbf{A}^\dagger)/(2i)$ are trace class. Show that for any trace class operator \mathbf{A} and for any orthonormal basis $(|a_n\rangle)_{n \geq 0}$, $\sum_{n \geq 0} \langle a_n | \mathbf{A} | a_n \rangle$ is an absolute convergent series. Show that its sum depends only on \mathbf{A} (this justifies the notation $\text{Tr}(\mathbf{A})$). When \mathbf{A} is Hermitian and trace class, show that $\text{Tr}(\mathbf{A})$ coincides with the sum of its eigenvalues counted with their multiplicity.

The set of trace class operators \mathbf{A} is noted by $\mathcal{K}^1(\mathcal{H})$: it is equipped with the trace norm also called nuclear norm: $\|\mathbf{A}\|_1 = \text{Tr}(\sqrt{\mathbf{A}^\dagger \mathbf{A}})$. A finite rank operator is automatically trace class: $\mathcal{K}^f(\mathcal{H}) \subset \mathcal{K}^1(\mathcal{H})$. More-over the completion of $\mathcal{K}^f(\mathcal{H})$ for the trace-class norm is $\mathcal{K}^1(\mathcal{H})$: any element of $\mathcal{K}^1(\mathcal{H})$ can be approximated for the trace norm topology by a sequence of finite rank operators. For any trace-class operators \mathbf{A}, \mathbf{B} , we have :

- $\text{Tr}(\mathbf{A}) \geq 0$ when $\mathbf{A}^\dagger = \mathbf{A} > 0$.
- $\text{Tr}(\mathbf{A})$ real when $\mathbf{A}^\dagger = \mathbf{A}$.
- $\text{Tr}(\mathbf{A}^\dagger) = (\text{Tr}(\mathbf{A}))^\dagger$ where $^\dagger = *$ stands for the conjugation of complex number.
- \mathbf{AB} and \mathbf{BA} are also trace class and $\text{Tr}(\mathbf{AB}) = \text{Tr}(\mathbf{BA})$.

For any trace class operator \mathbf{A} and any bounded operator \mathbf{M} , the operators \mathbf{AM} is also trace class: More over $|\text{Tr}(\mathbf{AM})| \leq \|\mathbf{M}\| \|\mathbf{A}\|_1$. Thus for any $\mathbf{M} \in \mathcal{B}(\mathcal{H})$, $\mathcal{K}^1(\mathcal{H}) \ni \mathbf{A} \mapsto \text{Tr}(\mathbf{AM}) \in \mathbb{C}$ is a continuous linear operator of the Banach space $\mathcal{K}^1(\mathcal{H})$ equipped with the trace norm. Conversely, any linear map from $\mathcal{K}^1(\mathcal{H})$ to \mathbb{C} that is continuous with the trace norm coincides with $\mathcal{K}^1(\mathcal{H}) \ni \mathbf{A} \mapsto \text{Tr}(\mathbf{AM})$ for some $\mathbf{M} \in \mathcal{B}(\mathcal{H})$. The dual of $\mathcal{K}^1(\mathcal{H})$ for the trace-class norm is $\mathcal{B}(\mathcal{H})$.

A compact operator \mathbf{A} is an Hilbert-Schmidt operator if, and only if, $\text{Tr}(\mathbf{A}^\dagger \mathbf{A}) < +\infty$. The set of Hilbert-Schmidt operators is denoted by $\mathcal{K}^2(\mathcal{H})$. Equipped with the Frobenius scalar product $\text{Tr}(\mathbf{AB}^\dagger)$, this space admits an Hilbert-space structure: the Frobenius norm \mathbf{A} is denoted by $\|\mathbf{A}\|_2 = \sqrt{\text{Tr}(\mathbf{A}^\dagger \mathbf{A})}$. We have $\mathcal{K}^f(\mathcal{H}) \subset \mathcal{K}^1(\mathcal{H}) \subset \mathcal{K}^2(\mathcal{H})$. More-over, the closure of $\mathcal{K}^f(\mathcal{H})$ with the Frobenius norm coincides with $\mathcal{K}^2(\mathcal{H})$.

We have the following list of properties:

1. For any $\mathbf{A} \in \mathcal{K}^1(\mathcal{H}) \subset \mathcal{K}^2(\mathcal{H})$:

$$\|\mathbf{A}\|_2 \leq \|\mathbf{A}\|_1, \quad |\text{Tr}(\mathbf{A})| \leq \|\mathbf{A}\|_1, \quad \|\mathbf{A}^\dagger\|_1 = \|\mathbf{A}\|_1.$$

2. if $\mathbf{A} \in \mathcal{K}^1(\mathcal{H})$ and $\mathbf{B} \in \mathcal{B}(\mathcal{H})$, then \mathbf{AB} and \mathbf{BA} are in $\mathcal{K}^1(\mathcal{H})$ and

$$\|\mathbf{AB}\|_1 = \|\mathbf{BA}\|_1 \leq \|\mathbf{A}\|_1 \|\mathbf{B}\|.$$

3. if \mathbf{A} and \mathbf{B} belong to $\mathcal{K}^2(\mathcal{H})$, then \mathbf{AB} belongs to $\mathcal{K}^1(\mathcal{H})$ and

$$\|\mathbf{AB}\|_1 = \|\mathbf{BA}\|_1 \leq \|\mathbf{A}\|_2 \|\mathbf{B}\|_2.$$

4. if $\mathbf{A} \in \mathcal{K}^2(\mathcal{H})$ and $\mathbf{B} \in \mathcal{B}(\mathcal{H})$, then \mathbf{AB} and \mathbf{BA} are in $\mathcal{K}^2(\mathcal{H})$.

An operator $\boldsymbol{\rho} \in \mathcal{K}^1(\mathcal{H})$ that is additionally Hermitian, non negative and of trace one is called a density operator. The set of density operators is a closed convex subset of the Banach space $\mathcal{K}^1(\mathcal{H})$ equipped with the trace norm.

Appendix C

Linear quantum operations

A linear quantum operation \mathbb{K} is a linear superoperator acting on the space of the density matrices in the system's Hilbert space \mathcal{S} , and satisfying the following properties:

- \mathbb{K} is trace-preserving or decreasing. This is, $0 \leq \text{Tr}(\mathbb{K}(\rho)) \leq 1$ for any density matrix ρ .
- \mathbb{K} is completely positive. That is, not only does \mathbb{K} map positive operators to positive operators in the system's Hilbert space \mathcal{S} , but so does $\mathbf{I}_{\mathcal{H}} \otimes \mathbb{K}$ for positive operators in $\mathcal{H} \otimes \mathcal{S}$. Here \mathcal{H} is the Hilbert space of a second arbitrary system and $\mathbf{I}_{\mathcal{H}}$ is its identity operator.

Concerning the last property, it may seem that positivity of a superoperator would be sufficient to represent a physical process. However, in practice, the considered system can be entangled to another system before the physical process acts on it. It must still be the case that the total state of both systems remains a physical state with a positive density operator. This justifies the last property.

We have the following theorem called the Kraus representation theorem (see [50, page 368] for a proof):

Theorem 3. *Any linear quantum operation satisfying the above conditions, can be expressed in the form*

$$\mathbb{K}(\rho) = \sum_j \mathbf{M}_j \rho \mathbf{M}_j^\dagger$$

with

$$\mathbf{I}_{\mathcal{S}} - \sum_j \mathbf{M}_j^\dagger \mathbf{M}_j \geq 0.$$

The above formula is known as the Kraus representation or the operator-sum representation of the linear quantum operation and the operators \mathbf{M}_j are known as the measurement operators. Moreover, \mathbb{K} is trace-preserving ($\text{Tr}(\mathbb{K}(\rho)) = \text{Tr}(\rho)$ for any density operator ρ) if, and only if, $\sum_j \mathbf{M}_j^\dagger \mathbf{M}_j = \mathbf{I}_{\mathcal{S}}$.

Linear quantum operations are also called *Kraus maps* or *quantum channels*. When not trace preserving, they are also called *partial Kraus maps*.

Exercice 26. Show that the partial trace versus \mathcal{H}_2 of any density operator on $\mathcal{H} = \mathcal{H}_1 \otimes \mathcal{H}_2$, yields a density operator on \mathcal{H}_1 . Show also that this map is onto. Show finally that it is completely positive and thus a Kraus map (quantum channel) from density operators on $\mathcal{H}_1 \otimes \mathcal{H}_2$ to density operators on \mathcal{H}_1 .

As soon as we make the additional assumption of a trace-preserving quantum operation, we can also prove some contraction properties. In this aim, we first define the quantum fidelity and quantum trace distance between two density matrices:

Definition 1. Consider two well-defined density matrices ρ and σ . The quantum trace distance $D(\rho, \sigma)$ and the quantum fidelity $F(\rho, \sigma)$ are then defined as follows:

$$D(\rho, \sigma) = \frac{1}{2} \text{Tr}(|\rho - \sigma|), \quad F(\rho, \sigma) = \text{Tr} \left(\sqrt{\rho^{1/2} \sigma \rho^{1/2}} \right),$$

where $|A| \equiv \sqrt{A^\dagger A}$ is the positive square root of $A^\dagger A$.

Remark 1. One can prove that (see [50, Chapter 9]) as soon as one of the density matrices is a projector state $\sigma = |\psi\rangle\langle\psi|$, the fidelity between ρ and σ is given by the standard form

$$F(\rho, \sigma) = \sqrt{\text{Tr}(\rho\sigma)} = \sqrt{\langle\psi|\rho|\psi\rangle}.$$

We have the following contraction properties for trace-preserving quantum operations:

Theorem 4. Suppose that \mathbb{K} is a trace-preserving quantum operation. Let ρ and σ be two well-defined density operators. Then

$$D(\mathbb{K}(\rho), \mathbb{K}(\sigma)) \leq D(\rho, \sigma) \quad \text{and} \quad F(\mathbb{K}(\rho), \mathbb{K}(\sigma)) \geq F(\rho, \sigma).$$

The proof of this theorem is beyond the scope of these notes and we refer to [50, Chapter 9] for a rigorous proof.

Appendix D

Single-frequency Averaging

We summarize here the basic result and approximations used in these notes for single-frequency systems. One can consult [55, 35, 7] for much more elaborated results. We emphasize a particular computational trick that simplifies notably second order calculations. This trick is a direct extension of a computation explained in [41] and done by the soviet physicist Kapitza for deriving the average motion of a particle in a highly oscillating force field.

Consider the oscillating system of dimension n ;

$$\frac{dx}{dt} = \varepsilon f(x, t, \varepsilon), \quad x \in \mathbb{R}^n$$

with f smooth and of period T versus t , where ε is a small parameter. For x bounded and $|\varepsilon|$ small enough, there exists a time-periodic change of variables, close to identity, of the form

$$x = z + \varepsilon w(z, t, \varepsilon)$$

with w smooth function and T -periodic versus t , such that, the differential equation in the z frame reads:

$$\frac{dz}{dt} = \varepsilon \bar{f}(z, \varepsilon) + \varepsilon^2 f_1(z, t, \varepsilon)$$

with

$$\bar{f}(z, \varepsilon) = \frac{1}{T} \int_0^T f(z, t, \varepsilon) dt$$

and f_1 smooth and T -periodic versus t .

Thus we can approximate on interval $[0, \frac{T}{\varepsilon}]$ the trajectories of the oscillating system $\frac{dx}{dt} = \varepsilon f(x, t, \varepsilon)$ by those of the average one $\frac{dz}{dt} = \varepsilon \bar{f}(z, \varepsilon)$. More precisely, if $x(0) = z(0)$ then $x(t) = z(t) + O(|\varepsilon|)$ for all $t \in [0, \frac{T}{\varepsilon}]$. Since this approximation is valid on intervals of length T/ε , we say that this approximation is of order one. One also speaks of secular approximation.

The function $w(z, t, \varepsilon)$ appearing in this change of variables is given by a t -primitive of $f - \bar{f}$. If we replace x by $z + \varepsilon w$ in $\frac{dx}{dt} = \varepsilon f$ we get

$$\left(I_d + \varepsilon \frac{\partial w}{\partial z} \right) \frac{d}{dt} z = \varepsilon f - \varepsilon \frac{\partial w}{\partial t} = \varepsilon \bar{f} + \varepsilon \left(f - \bar{f} - \frac{\partial w}{\partial t} \right).$$

Since for each z , the function $\int_0^t (f(z, \tau, \varepsilon) - \bar{f}(z, \varepsilon)) d\tau$ is T -periodic, we set

$$w(z, t, \varepsilon) = \int_0^t (f(z, \tau, \varepsilon) - \bar{f}(z, \varepsilon)) d\tau + c(z, \varepsilon)$$

where the integration "constant" $c(z, \varepsilon)$ can be set arbitrarily. We will see that a clever choice for c corresponds to w with a null time-average. We have

$$\left(I_d + \varepsilon \frac{\partial w}{\partial z}(z, t, \varepsilon) \right) \frac{d}{dt} z = \varepsilon \bar{f}(z, \varepsilon) + \varepsilon (f(z + \varepsilon w(z, t, \varepsilon), t, \varepsilon) - f(z, t, \varepsilon))$$

and thus

$$\frac{d}{dt} z = \varepsilon \left(I_d + \varepsilon \frac{\partial w}{\partial z}(z, t, \varepsilon) \right)^{-1} \left(\bar{f}(z, \varepsilon) + f(z + \varepsilon w(z, t, \varepsilon), t, \varepsilon) - f(z, t, \varepsilon) \right).$$

We obtain the form we were looking for, $\frac{d}{dt} z = \varepsilon \bar{f} + \varepsilon^2 f_1$, with

$$f_1(z, t, \varepsilon) = \frac{1}{\varepsilon} \left(\left(I_d + \varepsilon \frac{\partial w}{\partial z}(z, t, \varepsilon) \right)^{-1} - I_d \right) \bar{f}(z, \varepsilon) + \left(I_d + \varepsilon \frac{\partial w}{\partial z}(z, t, \varepsilon) \right)^{-1} \frac{f(z + \varepsilon w(z, t, \varepsilon), t, \varepsilon) - f(z, t, \varepsilon)}{\varepsilon}.$$

Notice that

$$f_1(z, t, \varepsilon) = \frac{\partial f}{\partial z}(z, t, \varepsilon) w(z, t, \varepsilon) - \frac{\partial w}{\partial z}(z, t, \varepsilon) \bar{f}(z, \varepsilon) + O(\varepsilon).$$

The second order approximation is then obtained by taking the time-average of f_1 . Its justification is still based on a time-periodic change of variables of type $z = \zeta + \varepsilon^2 \varpi(\zeta, t, \varepsilon)$, i.e., close to identity but up-to second order in ε .

If we adjust $c(z, \varepsilon)$ in order to have w of null time-average, then the time-average of $\frac{\partial w}{\partial z}$ is also zero. Thus, up to order one terms in ε , the time-average of f_1 is identical to the time average of $\frac{\partial f}{\partial z} w$. For this particular choice of w , the second order approximation reads

$$\frac{d}{dt} x = \varepsilon \bar{f} + \varepsilon^2 \overline{\frac{\partial f}{\partial x} w}$$

where the symbol " $\overline{\quad}$ " stands for time-average. In the case that the first-order approximation $\varepsilon \bar{f}$ vanishes, the solutions of the oscillating system $\frac{d}{dt} x = \varepsilon f$ and those of the second order approximation here above remain close on time intervals of length $\frac{T}{\varepsilon^2}$.

A suggestive manner to compute this second order approximation and very efficient on physical examples is due to Kapitza [41, page 147]. One decomposes $x = \bar{x} + \delta x$ in a non-oscillating part \bar{x} of order 0 in ε and an oscillating part δx of order 1 in ε and of null time-average. One has

$$\frac{d}{dt} \bar{x} + \frac{d}{dt} \delta x = \varepsilon f(\bar{x} + \delta x, t, \varepsilon).$$

Since $\delta x = O(\varepsilon)$, we have

$$f(\bar{x} + \delta x, t, \varepsilon) = f(\bar{x}, t, \varepsilon) + \frac{\partial f}{\partial x}(\bar{x}, t, \varepsilon) \delta x + O(\varepsilon^2).$$

Thus

$$\frac{d}{dt} \bar{x} + \frac{d}{dt} \delta x = \varepsilon f(\bar{x}, t, \varepsilon) + \varepsilon \frac{\partial f}{\partial x}(\bar{x}, t, \varepsilon) \delta x + O(\varepsilon^3).$$

Since $\frac{d}{dt}\bar{x} = \varepsilon\bar{f}(\bar{x}, \varepsilon) + O(\varepsilon^2)$, identification of oscillating terms of null time-average and of first order in ε provides

$$\frac{d}{dt}(\delta x) = \varepsilon(f(\bar{x}, t, \varepsilon) - \bar{f}(\bar{x}, \varepsilon)).$$

This equation can be integrated in time since \bar{x} is almost constant. The integration constant is fixed by the constraint on the time-average of δx . Finally,

$$\delta x = \varepsilon \int_0^t (f(\bar{x}, \tau, \varepsilon) - \bar{f}(\bar{x}, \varepsilon)) d\tau + \varepsilon c(\bar{x}, \varepsilon)$$

is a function of $(\bar{x}, t, \varepsilon)$, $\delta x = \delta x(\bar{x}, t, \varepsilon)$, T -periodic versus t and of null time-average (good choice of $c(\bar{x}, \varepsilon)$). Let us plug this function $\delta x(\bar{x}, t, \varepsilon)$ into the differential equation for \bar{x} ,

$$\frac{d}{dt}\bar{x} = \varepsilon\bar{f}(\bar{x}, \varepsilon) + \varepsilon\frac{\partial f}{\partial x}(\bar{x}, t, \varepsilon)\delta x(\bar{x}, t, \varepsilon) + O(\varepsilon^3),$$

And let us take its time-average. We get

$$\frac{d}{dt}\bar{x} = \varepsilon\bar{f}(\bar{x}, \varepsilon) + \varepsilon^2\bar{f}_1(\bar{x}, \varepsilon)$$

with

$$\varepsilon\bar{f}_1(\bar{x}, \varepsilon) = \frac{1}{T} \int_0^T \frac{\partial f}{\partial x}(\bar{x}, t, \varepsilon)\delta x(\bar{x}, t, \varepsilon) dt$$

We recover then exactly the previous second order approximation.

Appendix E

Pontryaguin Maximum Principe

This appendix is a summary of the necessary optimality conditions called Pontryaguin Maximum Principe (PMP) for finite dimensional systems (for tutorial exposures see [17] or [2]).

Take a control system of the form $\frac{d}{dt}x = f(x, u)$, $x \in \mathbb{R}^n$, $u \in U \subset \mathbb{R}^m$ with a cost to maximize of the form $J = \int_0^T c(x, u)dt$ ($T > 0$), initial condition $x(0) = x^a$ and final condition $x(T) = x^b$. The functions $f \in \mathbb{R}^n$ and $c \in \mathbb{R}$ are assumed to be C^1 functions of their arguments. If the couple $[0, T] \ni t \mapsto (x(t), u(t)) \in \mathbb{R}^n \times U$ is optimal, then there exists a never vanishing and absolutely continuous function¹ $[0, T] \ni t \mapsto p \in \mathbb{R}^n$ and a constant $p_0 \in]-\infty, 0]$ such that:

(i) with $\mathbb{H}(x, p, u) = p_0 c(x, u) + \sum_{i=1}^n p_i f_i(x, u)$, x and p are solutions of

$$\frac{d}{dt}x = \frac{\partial \mathbb{H}}{\partial p}(x, p, u), \quad \frac{d}{dt}p = -\frac{\partial \mathbb{H}}{\partial x}(x, p, u),$$

(ii) for almost all $t \in [0, T]$

$$\mathbb{H}(x(t), p(t), u(t)) = \bar{\mathbb{H}}(x(t), p(t)) \quad \text{where} \quad \bar{\mathbb{H}}(x, p) = \max_{v \in U} \mathbb{H}(x, p, v).$$

(iii) $\bar{\mathbb{H}}(x(t), p(t))$ is independent of t and its value \bar{h} , depends on T if the final time is fixed to T or $\bar{h} = 0$ if T is free (as for minimum time problem with U bounded and $c = -1$).

Conditions (i), (ii) and (iii) form the Pontryaguin Maximum Principe (PMP). Couples $[0, T] \ni t \mapsto (x(t), u(t))$ satisfying these conditions are called extremals: if $p_0 = 0$ the extremal is called abnormal; if $p_0 < 0$ the extremal is called normal. Strictly abnormal extremals are abnormal ((x, p) satisfies (i), (ii) and (iii) with $p_0 = 0$) and not normal ((x, p) never satisfies (i), (ii) and (iii) for $p_0 < 0$). Abnormal extremals do not depend on the cost $c(x, u)$ but only on the system itself $\frac{d}{dt}x = f(x, u)$: they are strongly related to system controllability (for driftless systems where $f(x, u)$ is linear versus x , see [15]).

Assume that we have a normal extremal (x, u) , i.e. satisfying conditions (i), (ii) and (iii) with $p_0 < 0$. Assume also that $u \mapsto \mathbb{H}(x, p, u)$ is differentiable, α concave, bounded from

¹An absolutely continuous function $[0, T] \ni t \mapsto z \in \mathbb{R}^m$ satisfies, by definition, the following condition: for all $\epsilon > 0$, there exists $\eta > 0$ such that, for any ordered sequence $0 \leq t_1 \leq \dots \leq t_k \leq T$ of arbitrary length k fulfilling $\sum_{i=1}^{k-1} |t_{i+1} - t_i| \leq \eta$, we have $\sum_{i=1}^{k-1} |z(t_{i+1}) - z(t_i)| \leq \epsilon$. Such functions are differentiable versus t , for almost all $t \in [0, T]$ and, moreover we have $z(t) = z(0) + \int_0^t z(s)ds$.

above, infinite at infinity and that $U = \mathbb{R}^m$. Then condition (ii) is then equivalent to $\frac{\partial \mathbb{H}}{\partial u} = 0$. Replacing p by p/p_0 , PMP conditions (i), (ii) and (iii) coincide with the usual *first order stationary conditions* (\dagger means transpose here):

$$\frac{d}{dt}x = f, \quad \frac{d}{dt}p = - \left(\frac{\partial f}{\partial x} \right)^\dagger p - \left(\frac{\partial c}{\partial x} \right)^\dagger, \quad \left(\frac{\partial f}{\partial u} \right)^\dagger p + \left(\frac{\partial c}{\partial u} \right)^\dagger = 0 \quad (\text{E.1})$$

with the boundary conditions $x(0) = x^a$, $x(T) = x^b$. From static equations in (E.1) we can express generally u as a function of (x, p) , denoted here by $u = k(x, p)$. Then $\overline{\mathbb{H}}(x, p) = \mathbb{H}(x, p, k(x, p))$ and the first order stationary conditions form an Hamiltonian system

$$\frac{d}{dt}x = \frac{\partial \overline{\mathbb{H}}}{\partial p}(x, p), \quad \frac{d}{dt}p = - \frac{\partial \overline{\mathbb{H}}}{\partial x}(x, p)$$

since $\frac{\partial \overline{\mathbb{H}}}{\partial p} = \frac{\partial \mathbb{H}}{\partial p} + \frac{\partial \mathbb{H}}{\partial u} \frac{\partial k}{\partial p} = \frac{\partial \mathbb{H}}{\partial p}$ because $\frac{\partial \mathbb{H}}{\partial u} \equiv 0$ (idem for $\frac{\partial \overline{\mathbb{H}}}{\partial x}$). In general, this Hamiltonian system is not integrable in the Arnol'd-Liouville sense and numerical methods are then used.

These first order stationary conditions can be obtained directly using standard variation calculus based on the Lagrange method. The adjoint state p is the Lagrange multipliers associated to the constraint $\frac{d}{dt}x = f(x, u)$. Assume T given and consider the Lagrangian $L(x, \dot{x}, p, u) = c(x, u) + \sum_{i=1}^n p_i (f_i(x, u) - \dot{x}_i)$ associated to

$$\begin{aligned} & \max_{u, x} \int_0^T c(x, u) dt. \\ & f(x, u) - \frac{d}{dt}x = 0 \\ & x(0) = x^a, \quad x(T) = x^b \end{aligned}$$

The first variation $\delta \mathcal{L}$ of $\mathcal{L} = \int_0^T L(x, \dot{x}, p, u) dt$ should vanish for any variation δx , δp and δu such that $\delta x(0) = \delta x(T) = 0$:

- $\delta \mathcal{L} = 0$ for any δp yields to $\frac{d}{dt}x = f(x, u)$;
- $\delta \mathcal{L} = 0$ for any δx with $\delta x(0) = \delta x(T) = 0$ yields to $\frac{d}{dt}p = - \left(\frac{\partial f}{\partial x} \right)^\dagger p - \left(\frac{\partial c}{\partial x} \right)^\dagger$
- $\delta \mathcal{L} = 0$ for any δu yields to $\frac{\partial c}{\partial u} + \sum_i p_i \frac{\partial f_i}{\partial u} = 0$

We recover the stationary conditions (E.1).

It is then simple to show that the stationary conditions for

$$\begin{aligned} & \max_{u, x} \int_0^T c(x, u) dt + l(x(T)), \\ & f(x, u) - \frac{d}{dt}x = 0 \\ & x(0) = x^a \end{aligned}$$

where the final condition $x(T) = x^b$ is replaced by a final cost $l(x(T))$ (l a C^1 function), remain unchanged except for the boundary conditions becoming

$$x(0) = x^a, \quad p(T) = \left(\frac{\partial l}{\partial x} \right)^\dagger (x(T)).$$

Appendix F

Markov chains, martingales and convergence theorems

This Appendix has for aim to give a very brief overview of some definitions and some theorems in the theory of random processes. The stability Theorems 5, 6 and 7 can be seen as stochastic analogues of deterministic Lyapunov function techniques.

We start the appendix by defining three types of convergence for random processes:

Definition 2. Consider (X_n) a sequence of random variables defined on the probability space (Ω, \mathcal{F}, p) and taking values in a metric space \mathcal{X} . The random process X_n is said to,

- converge in probability towards the random variable X if for all $\epsilon > 0$,

$$\lim_{n \rightarrow \infty} p(|X_n - X| > \epsilon) = \lim_{n \rightarrow \infty} p(\omega \in \Omega \mid |X_n(\omega) - X(\omega)| > \epsilon) = 0;$$

- converge almost surely towards the random variable X if

$$p\left(\lim_{n \rightarrow \infty} X_n = X\right) = p\left(\omega \in \Omega \mid \lim_{n \rightarrow \infty} X_n(\omega) = X(\omega)\right) = 1;$$

- converge in mean towards the random variable X if

$$\lim_{n \rightarrow \infty} \mathbb{E}(|X_n - X|) = 0.$$

We can prove that the almost sure convergence and the convergence in mean imply the convergence in probability. However no such relation can be proved between the convergence in mean and the almost sure convergence in general.

Let (Ω, \mathcal{F}, p) be a probability space, and let $\mathcal{F}_1 \subseteq \mathcal{F}_2 \subseteq \dots \subseteq \mathcal{F}$ be a nondecreasing family of sub- σ -algebras. We have the following definitions

Definition 3. The sequence $(X_n, \mathcal{F}_n)_{n=1}^{\infty}$ is called a Markov process with respect to $F = (\mathcal{F}_n)_{n=1}^{\infty}$, if for $n' > n$ and any measurable function $f(x)$ with $\sup_x |f(x)| < \infty$,

$$\mathbb{E}(f(X_{n'}) \mid \mathcal{F}_n) = \mathbb{E}(f(X_{n'}) \mid X_n).$$

Definition 4. The sequence $(X_n, \mathcal{F}_n)_{n=1}^{\infty}$ is called respectively a supermartingale, a submartingale or a martingale, if $\mathbb{E}(|X_n|) < \infty$ for $n = 1, 2, \dots$, and

$$\mathbb{E}(X_n \mid \mathcal{F}_m) \leq X_m \quad (p \text{ almost surely}), \quad n \geq m,$$

or

$$\mathbb{E}(X_n \mid \mathcal{F}_m) \geq X_m \quad (p \text{ almost surely}), \quad n \geq m,$$

or finally,

$$\mathbb{E}(X_n \mid \mathcal{F}_m) = X_m \quad (p \text{ almost surely}), \quad n \geq m.$$

Remark 2. A time-continuous version of the above definitions can also be considered for $(X_t, \mathcal{F}_t)_{t \geq 0}$, where $F = (\mathcal{F}_t)_{t \geq 0}$, is non decreasing family of sub- σ -algebras of \mathcal{F} .

The following theorem characterizes the convergence of bounded martingales:

Theorem 5 (Doob's first martingale convergence theorem). Let $(X_n, \mathcal{F}_n)_{n < \infty}$ be a submartingale such that $(x^+$ is the positive part of x)

$$\sup_n \mathbb{E}(X_n^+) < \infty.$$

Then $\lim_n X_n (= X_\infty)$ exists with probability 1, and $\mathbb{E}(X_\infty^+) < \infty$.

For a proof we refer to [47, Chapter 2, Page 43].

Here, we recall two results that are often referred as the stochastic versions of the Lyapunov stability theory and the LaSalle's invariance principle. For detailed discussions and proofs we refer to [40, Sections 8.4 and 8.5]. The first theorem is the following:

Theorem 6 (Doob's Inequality). Let $\{X_n\}$ be a Markov chain on state space \mathcal{X} . Suppose that there is a non-negative function $V(x)$ satisfying $\mathbb{E}(V(X_1) \mid X_0 = x) - V(x) = -k(x)$, where $k(x) \geq 0$ on the set $\{x : V(x) < \lambda\} \equiv Q_\lambda$. Then

$$p \left(\sup_{\infty > n \geq 0} V(X_n) \geq \lambda \mid X_0 = x \right) \leq \frac{V(x)}{\lambda}.$$

Corollary 1. Consider the same assumptions as in Theorem 6. Assume moreover that there exists $\bar{x} \in \mathcal{X}$ such that $V(\bar{x}) = 0$ and that $V(x) \neq 0$ for all x different from \bar{x} . Then the Theorem 6 implies that the Markov process X_n is **stable in probability** around \bar{x} , i.e.

$$\lim_{x \rightarrow \bar{x}} p \left(\sup_n \|X_n - \bar{x}\| \geq \epsilon \mid X_0 = x \right) = 0, \quad \forall \epsilon > 0.$$

Theorem 7. Let $\{X_n\}$ be a Markov chain on the compact state space S . Suppose that there exists a non-negative function $V(x)$ satisfying $\mathbb{E}(V(X_{n+1}) \mid X_n = x) - V(x) = -k(x)$, where $k(x) \geq 0$ is a positive continuous function of x . Then the ω -limit set (in the sense of almost sure convergence) of X_n is included in the following set

$$I = \{X \mid k(X) = 0\}.$$

Trivially, the same result holds true for the case where $\mathbb{E}(V(X_{n+1}) \mid X_n = x) - V(x) = k(x)$ ($V(X_n)$ is a submartingale and not a supermartingale), with $k(x) \geq 0$ and $V(x)$ bounded from above.

The proof is just an application of the Theorem 1 in [40, Ch. 8], which shows that $k(X_n)$ converges to zero for almost all paths. It is clear that the continuity of $k(x)$ with respect to x and the compactness of S implies that the ω -limit set of X_n is necessarily included in the set I .

Appendix G

Model reduction and singular perturbations

This appendix is based on [33], a geometric and coordinates free approach for singularly perturbed differential equations describing systems with two time-scales: a fast and converging one and a slow one (converging, diverging, ...). This Appendix is directly inspired from section 3 of [31] and is related to the following more general issue: what is model reduction ?

G.1 Attractive invariant manifold

For dynamical system, $\frac{d}{dt}x = v(x)$, $x \in \mathbb{R}^n$ displayed on figure G.1, reduction is possible with an *attractive invariant manifold* Σ . A sub-manifold Σ is invariant versus v , if v is tangent to Σ , i.e., if any trajectory starting on Σ remains on Σ . Σ is called (locally) attractive if any trajectory starting near Σ tends to Σ as time increases. Reduction corresponds then to restriction of the dynamics to Σ . Such restriction is well defined since Σ is invariant.

It seems then natural to approximate trajectories of the complete system $\dot{x} = v(x)$ by trajectories on Σ . In fact, such an approximation is proved to be valid when, roughly speaking, the dynamics transverse to Σ (the dynamics that are neglected) are faster and converge to Σ . The main difficulty is thus to obtain the equations of Σ or, at least, good approximations of them, from the knowledge of v .

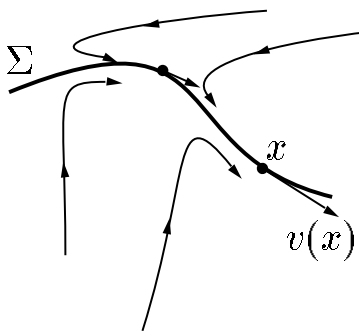

Figure G.1: Model reduction seen as restriction of the dynamics to an invariant attractive sub-manifold of the state manifold

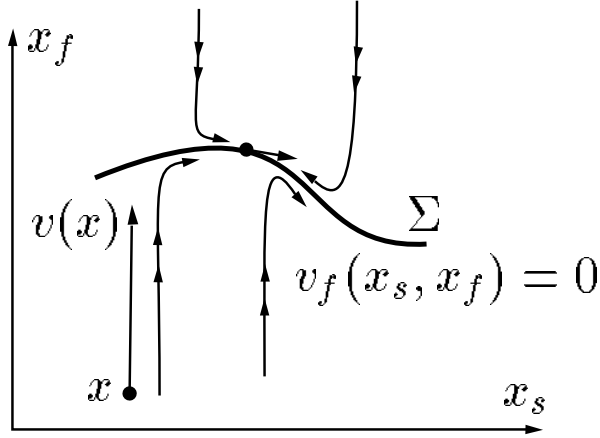

Figure G.2: Tikhonov normal form when the vector-field $v = (v_s, v_f)$ is quasi vertical in the $x = (x_s, x_f)$ coordinates.

Efficient approximations can be obtained by asymptotic expansion versus the small parameter $0 < \varepsilon \ll 1$ attached to the time-scale difference ensuring the existence of such invariant attractive manifold Σ_ε depending smoothly on ε .

G.2 Tikhonov normal form

Assume that modeling coordinates yield to a state those components can be decomposed into two subsets of components $x = (x_s, x_f)$ with the following form called Tikhonov form

$$\frac{d}{dt}x_s = \varepsilon v_s(x_s, x_f, \varepsilon), \quad \frac{d}{dt}x_f = v_f(x_s, x_f, \varepsilon) \quad (\text{G.1})$$

where $0 < \varepsilon \ll 1$. Very often, such systems are written with the time-scale $\tau = \varepsilon t$:

$$\frac{dx_s}{d\tau} = v_s(x_s, x_f, \varepsilon), \quad \varepsilon \frac{dx_f}{d\tau} = v_f(x_s, x_f, \varepsilon).$$

The terminology *singular perturbations*' comes from the fact that the small parameter ε multiplies the highest derivative (here $dx_f/d\tau$). More details on this classical standpoint can be found, e.g., in [64]. In the sequel we always consider the time-scale t and approximations of trajectories for $t \in [0, 1/\varepsilon]$ and with $\varepsilon > 0$ but close to 0.

Assume that the fast part is hyperbolically stable, i.e., that the sub-system $\frac{d}{dt}x_f = v_f(x_s, x_f, \varepsilon)$ with x_s fixed, admits (locally) an equilibrium with characteristic exponents (eigenvalues of $\frac{\partial v_f}{\partial x_f}$ at this equilibrium) having a strictly negative real part. Then the slow approximation is obtained by the quasi-steady-state method:

$$\begin{cases} \frac{d}{dt}x_s &= \varepsilon v_s(x_s, x_f, \varepsilon) \\ 0 &= v_f(x_s, x_f, \varepsilon). \end{cases}$$

The algebraic equations, $v_f = 0$, correspond here to an approximation up to terms of order 1 in ε , of Σ_ε equations. These coordinates (x_s, x_f) where the quasi-steady-state method applies, and where the vector field v is quasi-vertical (see figure G.2) in the (x_s, x_f) coordinates are clearly very specific.

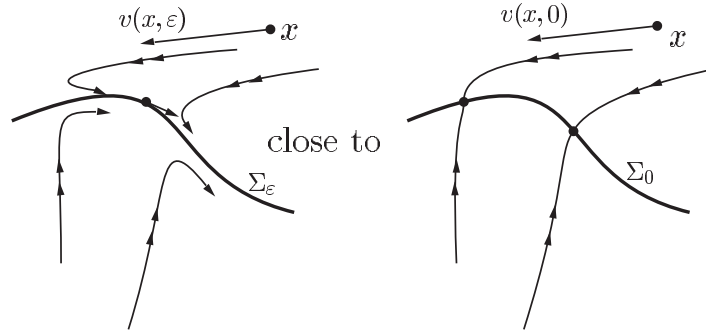

Figure G.3: Coordinate free setting of dynamical system $\frac{d}{dt}x = v(x, \epsilon)$ with two time-scales: fast asymptotically stable dynamics with slow ones.

G.3 Coordinate free setting

Since we are interested in developing a reduction method that do not assume such special Tikhonov coordinates (x_s, x_f) , a coordinate free point of view is required. A first geometric definition of singularly perturbed systems due to Fenichel [33] is as follows.

Consider the dynamical system

$$\dot{x} = v(x, \epsilon), \quad x \in \mathbb{R}^n, \quad 0 \leq \epsilon \ll 1. \quad (\text{G.2})$$

This system is said to have two time-scales, a fast and asymptotically stable one and a slow one, if, and only if, the following two assumptions are satisfied

A1 for $\epsilon = 0$, (G.2) admits an equilibrium manifold of dimension n_s , $0 < n_s < n$, denoted by Σ_0 .

A2 for all $x_0 \in \Sigma_0$, the Jacobian matrix, $\left. \frac{\partial v}{\partial x} \right|_{(x_0, 0)}$ admits $n_f = n - n_s$ eigenvalues with a strictly negative real part (the eigenvalues are counted with their multiplicities).

This definition is illustrated in figure G.3. Assumption **A1** implies that the velocity $v(x, \epsilon)$ is large everywhere excepted for x in a neighborhood of Σ_0 where v is small and of order 1 in ϵ .

A1 and **A2** imply that, for $x_0 \in \Sigma_0$, the kernel, $E_0^c(x_0)$, of the linear operator $\left. \frac{\partial v}{\partial x} \right|_{(x_0, 0)}$ coincides with the tangent space of Σ_0 at x_0 . The linear space $E_0^s(x_0)$ corresponding to the eigenvalues with real negative part satisfies:

$$E_0^s(x_0) \oplus E_0^c(x_0) = \mathbb{R}^n.$$

The trajectories of the perturbed system are captured by a trapping region around Σ_0 and enter with a direction nearly parallel to $E_0^s(x_0)$.

Fenichel [33][part of theorem 9.1] proves the following result. It asserts, for ϵ small enough, the existence of a slow invariant attractive manifold Σ_ϵ for the perturbed system (G.2).

Theorem 8 (Fenichel, 1979). *Consider (G.2) satisfying **A1** and **A2**. Then, for every open and bounded subset Ω_0 of Σ_0 , there exists an open neighborhood V_0 of Ω_0 in \mathbb{R}^n , such that, for ϵ positive and small enough, the perturbed system (G.2) admits an attractive invariant sub-manifold Σ_ϵ contained in V_0 and close to Σ_0 .*

We are interested in approximations, up to terms of order 1 in ε , of slow trajectories for $t \in [0, 1/\varepsilon]$. Thus we need an approximation up to terms of order 2 for the slow dynamics: errors like ε^2 integrated over $t \in [0, 1/\varepsilon]$ will produce for $t = 1/\varepsilon$, distortions of magnitude less than or equal to ε ($\varepsilon^2 \times (1/\varepsilon) = \varepsilon$). This means that an approximation, up to terms of order 2 in ε , of Σ_ε equations is needed.

G.4 Approximation based on center manifold techniques

This section generalizes [31] where, in local coordinates x , a subset of n_s components of x , say x_s , are used as local coordinates on Σ_ε . As in [31] we exploit center manifold techniques used in bifurcation theory [24, 35].

Set

$$v(x, \varepsilon) = v_0(x) + \varepsilon v_1(x) + \varepsilon^2 v_2(x) + \dots$$

Under assumptions **A1** and **A2**, assume that $z \in \mathbb{R}^{n_s}$ parameterizes Σ_0 . This means that we have a smooth function $h_0 : \mathbb{R}^{n_s} \mapsto \mathbb{R}^n$ such that the image of h_0 belongs to Σ_ε . Thus $v_0(h_0(z)) = 0$ for all z . Moreover the rank of $D_z h_0$ is maximum and equal to n_s . Consequently $D_x v_0(h_0(z)) D_z h_0(z) \equiv 0$ and the range of $D_z h_0(z)$ corresponds to the kernel of $D_x v_0(h_0(z))$, i.e. the eigenspace with 0 eigenvalue. Since the other eigenvalues of $D_x v_0(h_0(z))$ have a strictly negative real part, exists $P_0(z)$ an invertible $n \times n$ matrix such that $D_x v_0(h_0(z)) = P_0(z) \Delta_0(z) P_0^{-1}(z)$ where $\Delta_0(z)$ is a block matrix

$$\Delta_0(z) = \begin{pmatrix} 0_{n_s, n_s} & 0_{n_s, n_f} \\ 0_{n_f, n_s} & \Lambda_{n_f, n_f} \end{pmatrix}$$

and Λ_{n_f, n_f} is a $n_f \times n_f$ matrix with eigen-values of strictly negative real parts.

We are looking for the following description of the slow dynamics on Σ_ε :

$$\frac{d}{dt} z = w_0(z) + \varepsilon w_1(z) + \varepsilon^2 w_2(z) + \dots \text{ with } x = h_0(z) + \varepsilon h_1(z) + \varepsilon^2 h_2(z) + \dots \quad (\text{G.3})$$

This means that if $z(t)$ is a solution of the above differential equation of size n_s , then $x(t)$ obtained with the above static mapping is automatically a solution of the initial system staying on Σ_ε . This implies the following invariance condition

$$\begin{aligned} & v_0\left(h_0(z) + \varepsilon h_1(z) + \varepsilon^2 h_2(z) + \dots\right) + \varepsilon v_1\left(h_0(z) + \varepsilon h_1(z) + \varepsilon^2 h_2(z) + \dots\right) \\ & \quad + \varepsilon^2 v_2\left(h_0(z) + \varepsilon h_1(z) + \varepsilon^2 h_2(z) + \dots\right) + \dots = \\ & D_z h_0(z) \left(w_0(z) + \varepsilon w_1(z) + \varepsilon^2 w_2(z) + \dots\right) + \varepsilon D_z h_1(z) \left(w_0(z) + \varepsilon w_1(z) + \varepsilon^2 w_2(z) + \dots\right) + \\ & \quad + \varepsilon^2 D_z h_2(z) \left(w_0(z) + \varepsilon w_1(z) + \varepsilon^2 w_2(z) + \dots\right) + \dots \quad (\text{G.4}) \end{aligned}$$

based on the time derivative of $x = h_0(z) + \varepsilon h_1(z) + \dots$ with $\frac{d}{dt} x = v_0(x) + \varepsilon v_1(x) + \dots$

Carr approximation lemma [24] of the center manifold Σ_ε says that if one fulfills (G.4) up to order k in ε then we have an approximation of Σ_ε and of its dynamics in z up to order k in ε .

For approximations up to order 2, we have to find w_0, w_1 and h_1 such that the zero order and first order terms in (G.4) cancels. Thus $w_0(z) = 0$ and (w_1, h_1) are given by

$$D_x v_0(h_0(z)) h_1 + v_1(h_0(z)) = D_z h_0(z) w_1.$$

Multiplying on the left by $D_x v_0(h_0(z)) = P_0(z)\Delta_0(z)P_0^{-1}(z)$ yields

$$\left(D_x v_0(h_0(z))\right)^2 h_1 = -D_x v_0(h_0(z))v_1(h_0(z)).$$

that reads

$$\begin{pmatrix} 0_{n_s, n_s} & 0_{n_s, n_f} \\ 0_{n_f, n_s} & \Lambda_{n_f, n_f}^2 \end{pmatrix} P_0(z)^{-1} h_1 = - \begin{pmatrix} 0_{n_s, n_s} & 0_{n_s, n_f} \\ 0_{n_f, n_s} & \Lambda_{n_f, n_f} \end{pmatrix} P_0(z)^{-1} v_1(h_0(z)).$$

Since Λ_{n_f, n_f} is invertible, it admits many solutions h_1 unique up to an arbitrary element in the kernel $D_x v_0(h_0(z))$, a gauge degree of freedom. With such h_1 , $D_x v_0(h_0(z))h_1 + v_1(h_0(z))$ is unique, does not depend on such gauge degrees of freedom and belongs automatically to kernel of $D_x v_0(h_0(z))$, i.e. to the range of $D_z h_0(z)$ which is of maximum dimension n_s . Thus it admits a unique left inverse $\left(D_z h_0(z)\right)_{\text{left}}^{-1}$ yielding to

$$w_1(z) = \left(D_z h_0(z)\right)_{\text{left}}^{-1} (D_x v_0(h_0(z))h_1 + v_1(h_0(z))).$$

When $x = (x_s, x_f)$ and $\frac{d}{dt}x = v(x, \varepsilon)$ reads

$$\frac{d}{dt}x_s = v_s(x_s, x_f, \varepsilon), \quad \frac{d}{dt}x_f = v_f(x_s, x_f, \varepsilon)$$

with $\frac{\partial v_f}{\partial x_f}(x, 0)$ is invertible at point x such that when $v(x, 0) = 0$, one recovers the formulae given in [31]. They correspond to the following differential algebraic system:

$$\frac{d}{dt}x_s = \left(1 + \frac{\partial v_s}{\partial x_f} \left(\frac{\partial v_f}{\partial x_f}\right)^{-2} \frac{\partial v_f}{\partial x_s}\right)_{(x_s, x_f, \varepsilon)}^{-1} \cdot v_s(x_s, x_f, \varepsilon), \quad v_f(x_s, x_f, \varepsilon) = 0.$$

Appendix H

Quantum Markovian feedback

The special class of Markovian feedback, introduced by H. Wiseman [70, 69, 71] for quantum systems, is a static output feedback. Thus such feedback schemes do not require the estimation in real-time of quantum state and are thus simpler to implement in practice. Another crucial property comes from the fact that the closed-loop dynamics of the ensemble average for the density operator remains linear. Thus closed-loop convergence analysis boils down to a linear question despite the open-loop and closed-loop statistical nonlinearities.

H.1 Discrete-time systems

Add to the Markov chain given by (3.26) a unitary control depending on a classical input u_k just after measurement at step k : the control input u parameterizes a unitary evolution U_u corresponding to the actuator process. Then (3.26) becomes

$$\rho_{k+1} = \frac{U_{u_k} \mathbb{K}_{y_k}(\rho_k) U_{u_k}^\dagger}{\text{Tr}(\mathbb{K}_{y_k}(\rho_k))}, \quad \text{with probability } p_{y_k}(\rho_k) = \text{Tr}(U_{u_k} \mathbb{K}_{y_k}(\rho_k) U_{u_k}^\dagger) \quad (\text{H.1})$$

where u_k and y_k are respectively the input and measurement output at step k .

A static output feedback is just setting $u_k = f(y_k)$ where the function f defines the output feedback law. The closed-loop dynamics reads

$$\rho_{k+1} = \frac{U_{f(y_k)} \mathbb{K}_{y_k}(\rho_k) U_{f(y_k)}^\dagger}{\text{Tr}(\mathbb{K}_{y_k}(\rho_k))}, \quad \text{with probability } p_{y_k}(\rho_k) = \text{Tr}(U_{f(y_k)} \mathbb{K}_{y_k}(\rho_k) U_{f(y_k)}^\dagger).$$

Since $\text{Tr}(U_u \mathbb{K}_y(\rho) U_u^\dagger) = \text{Tr}(\mathbb{K}_y(\rho))$ for any u , the ensemble average evolution of the density operator ρ reads

$$\bar{\rho}_{k+1} = \sum_y U_{f(y)} \mathbb{K}_y(\bar{\rho}_k) U_{f(y)}^\dagger \quad \bar{\rho}_0 = \rho_0$$

where $\bar{\rho}_k = \mathbb{E}(\rho_k | \rho_0)$. The closed-loop Kraus map $\bar{\mathbb{K}}(\cdot) = \sum_y U_{f(y)} \mathbb{K}_y(\cdot) U_{f(y)}^\dagger$ is a priori different from the open-loop one $\mathbb{K} = \sum_y \mathbb{K}_y$.

H.2 Continuous-time diffusive systems

H.2.1 Single-Input/Single-Output case (SISO)

Take a single input u_t and single output y_t system governed by the general stochastic master equation

$$d\rho_t = -i[H_0 + uH_1, \rho_t]dt + \left(L\rho L^\dagger - \frac{1}{2}L^\dagger L\rho - \frac{1}{2}\rho L^\dagger L \right) dt + \sqrt{\eta} \left(L\rho_t + \rho_t L^\dagger - \text{Tr} \left((L + L^\dagger)\rho_t \right) \rho_t \right) dW_t \quad (\text{H.2})$$

with detection efficiency $\eta \in [0, 1]$ and $\dot{y}_t dt = \sqrt{\eta} \text{Tr} \left((L + L^\dagger)\rho_t \right) dt + dW_t$. Consider a simple proportional controller of gain g

$$u = \bar{u} + g\dot{y}_t \quad (\text{H.3})$$

where \bar{u} is some constant. During the infinitesimal time $[t, t + dt]$ we measure first y_t and then apply this feedback law. We neglect the delay. Due to the singular nature of \dot{y}_t (it is not a bounded time function), the closed-loop equation is not obtained by just plugging $u dt = \bar{u} dt + g\sqrt{\eta} \text{Tr} \left((L + L^\dagger)\rho_t \right) dt + g dW_t$ in (H.2). The correct closed-loop equation has been derived in [70] and recalled in [68]. It admits the following form (Wiseman-Milburn stochastic master equation)

$$d\rho_t = -i \left[H_0 + \bar{u}H_1 + \frac{g\sqrt{\eta}}{2}(H_1L + L^\dagger H_1), \rho_t \right] dt + \sum_{s=1,2} \left(L_s \rho L_s^\dagger - \frac{1}{2}L_s^\dagger L_s \rho - \frac{1}{2}\rho L_s^\dagger L_s \right) dt + \sqrt{\eta_s} \left(L_s \rho_t + \rho_t L_s^\dagger - \text{Tr} \left((L_s + L_s^\dagger)\rho_t \right) \rho_t \right) dW_t^s \quad (\text{H.4})$$

with two Lindblad operators $L_1 = L - ig\sqrt{\eta}H_1$ and $L_2 = -ig\sqrt{1-\eta}H_1$, with efficiencies, $\eta_1 = \eta$ and $\eta_2 = 1 - \eta$, but with a single Wiener process $W_t^1 = W_t^2 = W_t$. We see a constant shift in the closed-loop Hamiltonian, $\frac{g\sqrt{\eta}}{2}(H_1L + L^\dagger H_1)$, appearing when writing the closed-loop equation this way. It could be possibly pre-compensated by an initial modification of H_0 through additional constant control inputs.

Thus the evolution of the ensemble average of ρ , i.e. $\bar{\rho}(t) = \mathbb{E}(\rho_t | \rho_0)$ obeys to the following deterministic closed-loop Lindblad master equation

$$\frac{d}{dt}\bar{\rho} = -i \left[H_0 + \bar{u}H_1 + \frac{g\sqrt{\eta}}{2}(H_1L + L^\dagger H_1), \bar{\rho} \right] + \sum_{s=1,2} \left(L_s \bar{\rho} L_s^\dagger - \frac{1}{2}L_s^\dagger L_s \bar{\rho} - \frac{1}{2}\bar{\rho} L_s^\dagger L_s \right) \quad (\text{H.5})$$

with initial condition $\bar{\rho}(0) = \rho_0$.

The above closed-loop equation (H.4) comes from the following direct computations exploiting the Ito rules. In closed-loop the correct value of $d\rho_t$ is given by the following formula coding the fact that the control u at time t is applied just after the measurement outcome y_t and corresponds to the unitary operation e^{-iudtH_1} with $u dt = \bar{u} dt + g\sqrt{\eta} \text{Tr} \left((L + L^\dagger)\rho_t \right) dt + g dW_t$:

$$d\rho_t = e^{-iudtH_1} \left\{ \rho_t - i[H_0, \rho_t]dt + \left(L\rho L^\dagger - \frac{1}{2}L^\dagger L\rho - \frac{1}{2}\rho L^\dagger L \right) dt + \sqrt{\eta} \left(L\rho_t + \rho_t L^\dagger - \text{Tr} \left((L + L^\dagger)\rho_t \right) \rho_t \right) dW_t \right\} e^{iudtH_1} - \rho_t.$$

Via the Baker-Campbell-Hausdorff formula,

$$e^A B e^{-A} = B + [A, B] + [A, [A, B]]/2 + O(\|A\|^3),$$

we get, with $A = -i(\bar{u}dt + g\sqrt{\eta} \text{Tr}((L + L^\dagger)\rho_t) dt + g dW_t) H_1$ and

$$B = \rho_t - i[H_0, \rho_t]dt + \left(L\rho L^\dagger - \frac{1}{2}L^\dagger L\rho - \frac{1}{2}\rho L^\dagger L\right) dt + \sqrt{\eta} \left(L\rho_t + \rho_t L^\dagger - \text{Tr}((L + L^\dagger)\rho_t) \rho_t\right) dW_t,$$

the following computations up to $O(dt^{3/2})$

$$\begin{aligned} [A, B] &= -i \left[(\bar{u} + g\sqrt{\eta} \text{Tr}((L + L^\dagger)\rho_t)) H_1, \rho_t \right] dt - ig [H_1, \rho_t] dW_t \\ &\quad - ig\sqrt{\eta} \left[H_1, L\rho_t + \rho_t L^\dagger - \text{Tr}((L + L^\dagger)\rho_t) \rho_t \right] dt + O(dt^{3/2}) \\ &= -i\bar{u} [H_1, \rho_t] dt - ig\sqrt{\eta} [H_1, L\rho_t + \rho_t L^\dagger] dt - ig [H_1, \rho_t] dW_t + O(dt^{3/2}) \end{aligned}$$

Remember that according to Ito rules, $dW_t = O(\sqrt{dt})$, $dW_t^2 = dt$ and $dt dW_t = O(dt^{3/2})$. Similarly we get

$$[A, [A, B]] = -g^2 [H_1, [H_1, \rho_t]] dt + O(dt^{3/2}).$$

Since $\|A\|^3 = O(dt^{3/2})$, we have, neglecting $O(dt^{3/2})$ terms according to Ito rules,

$$\begin{aligned} d\rho_t &= -i[H_0 + \bar{u}H_1, \rho_t]dt + \left(L\rho L^\dagger - \frac{1}{2}L^\dagger L\rho - \frac{1}{2}\rho L^\dagger L\right) dt \\ &\quad - ig\sqrt{\eta} [H_1, L\rho_t + \rho_t L^\dagger] dt - \frac{g^2}{2} [H_1, [H_1, \rho_t]] dt \\ &\quad + \sqrt{\eta} \left(L\rho_t + \rho_t L^\dagger - \text{Tr}((L + L^\dagger)\rho_t) \rho_t\right) dW_t - ig [H_1, \rho_t] dW_t \\ &= -i[H_0 + \bar{u}H_1 + \frac{g\sqrt{\eta}}{2}(LH_1 + H_1L^\dagger), \rho_t]dt + \mathcal{L} \left(L - ig\sqrt{\eta}H_1, \rho_t\right) dt \\ &\quad + \sqrt{\eta} \left((L - ig\sqrt{\eta}H_1)\rho_t + \rho_t(L^\dagger + ig\sqrt{\eta}H_1) - \text{Tr}((L + L^\dagger)\rho_t) \rho_t\right) dW_t \\ &\quad + \mathcal{L} \left(-i\sqrt{1-\eta}gH_1, \rho_t\right) dt - ig(1-\eta)[H_1, \rho_t]dW_t \end{aligned}$$

where $\mathcal{L}(L, \rho) = L\rho L^\dagger - \frac{1}{2}L^\dagger L\rho - \frac{1}{2}\rho L^\dagger L$. We recover (H.4) with the two Lindbladian terms associated to L_1 and L_2 .

H.2.2 Multi-Input/Multi-Output case (MIMO)

The above computations based on Ito rules and Baker-Campbell-Hausdorff formula provide directly the multi-input/multi-output extension of such static output feedback scheme (see [25] for a more elaborate derivation). Consider the m inputs (u_μ) and the p outputs (y_ν) of the

system governed by

$$\begin{aligned}
d\rho_t = -i \left[H_0 + \sum_{\mu=1}^m u_\mu H_\mu, \rho_t \right] dt \\
+ \sum_{\nu=1}^p \left(L_\nu \rho L_\nu^\dagger - \frac{1}{2} L_\nu^\dagger L_\nu \rho - \frac{1}{2} \rho L_\nu^\dagger L_\nu \right) dt \\
+ \sqrt{\eta_\nu} \left(L_\nu \rho_t + \rho_t L_\nu^\dagger - \text{Tr} \left((L_\nu + L_\nu^\dagger) \rho_t \right) \rho_t \right) dW_t^\nu \quad (\text{H.6})
\end{aligned}$$

where $\gamma_\nu \geq 0$, $\eta_\nu \in [0, 1]$ and (W_t^ν) are p independent Wiener processes and

$$\dot{y}_t^\nu dt = \sqrt{\eta_\nu} \text{Tr} \left((L_\nu + L_\nu^\dagger) \rho_t \right) dt + dW_t^\nu.$$

Consider the static output feedback

$$u_\mu = \bar{u}_\mu + \sum_{\nu=1}^p g_{\mu\nu} \dot{y}_t^\nu$$

with a $m \times p$ proportional gain matrix $(g_{\mu\nu})$. Then the closed-loop stochastic master equation reads

$$\begin{aligned}
d\rho_t = -i \left[H_0 + \sum_{\mu=1}^m \bar{u}_\mu H_\mu + \frac{1}{2} \sum_{\nu=1}^p \sqrt{\eta_\nu} (\tilde{H}_\nu L_\nu + L_\nu^\dagger \tilde{H}_\nu), \rho_t \right] dt + \\
\sum_{\nu=1}^p \sum_{s=1,2} \left(L_{\nu,s} \rho L_{\nu,s}^\dagger - \frac{1}{2} L_{\nu,s}^\dagger L_{\nu,s} \rho - \frac{1}{2} \rho L_{\nu,s}^\dagger L_{\nu,s} \right) dt \\
+ \sqrt{\eta_{\nu,s}} \left(L_{\nu,s} \rho_t + \rho_t L_{\nu,s}^\dagger - \text{Tr} \left((L_{\nu,s} + L_{\nu,s}^\dagger) \rho_t \right) \rho_t \right) dW_t^\nu \quad (\text{H.7})
\end{aligned}$$

with $\tilde{H}_\nu = \sum_{\mu=1}^m g_{\mu\nu} H_\mu$, $L_{\nu,1} = L_\nu - i\sqrt{\eta_\nu} \sum_{\mu=1}^m g_{\mu\nu} H_\mu$ and $L_{\nu,2} = -i\sqrt{1-\eta_\nu} \sum_{\mu=1}^m g_{\mu\nu} H_\mu$, with efficiencies, $\eta_{\nu,1} = \eta_\nu$ and $\eta_{\nu,2} = 1 - \eta_\nu$.

The ensemble average dynamics for $\bar{\rho}(t) = \mathbb{E}(\rho_t | \rho_0)$ reads then:

$$\begin{aligned}
\frac{d}{dt} \bar{\rho} = -i \left[H_0 + \sum_{\mu=1}^m \bar{u}_\mu H_\mu + \frac{1}{2} \sum_{\nu=1}^p \sqrt{\eta_\nu} (\tilde{H}_\nu L_\nu + L_\nu^\dagger \tilde{H}_\nu), \bar{\rho} \right] + \\
\sum_{\nu=1}^p \sum_{s=1,2} \left(L_{\nu,s} \bar{\rho} L_{\nu,s}^\dagger - \frac{1}{2} L_{\nu,s}^\dagger L_{\nu,s} \bar{\rho} - \frac{1}{2} \bar{\rho} L_{\nu,s}^\dagger L_{\nu,s} \right). \quad (\text{H.8})
\end{aligned}$$

The first experimental realization of such a multi-input multi-output Markovian feedback on a super-conducting qubit has been done in [18].

Bibliography

- [1] R. Adami and U. Boscain. Controllability of the Schrödinger equation via intersection of eigenvalues. In *44rd IEEE Conference on Decision and Control*, 2005.
- [2] V. Alexeev, E. Galeev, and V. Tikhomirov. *Recueil de Problèmes d'Optimisation*. Editions Mir, Moscou, 1987.
- [3] R. Alicki and K. Lendi. *Quantum Dynamical Semigroups and Applications*. Lecture Notes in Physics. Springer, second edition, 2007.
- [4] H. Amini, C. Pellegrini, and P. Rouchon. Stability of continuous-time quantum filters with measurement imperfections. *Russian Journal of Mathematical Physics*, 21(3):297–315–, 2014.
- [5] H. Amini, R.A. Somaraju, I. Dotsenko, C. Sayrin, M. Mirrahimi, and P. Rouchon. Feedback stabilization of discrete-time quantum systems subject to non-demolition measurements with imperfections and delays. *Automatica*, 49(9):2683–2692, September 2013.
- [6] Nina H Amini, Maël Bompais, and Clément Pellegrini. On asymptotic stability of quantum trajectories and their cesaro mean. *Journal of Physics A: Mathematical and Theoretical*, 54(38):385304, sep 2021.
- [7] V. Arnold. *Chapitres Supplémentaires de la Théorie des Equations Différentielles Ordinaires*. Mir Moscou, 1980.
- [8] R. Azouit, F. Chittaro, A. Sarlette, and P. Rouchon. Towards generic adiabatic elimination for bipartite open quantum systems. *Quantum Science and Technology*, 2:044011, 2017.
- [9] R. Azouit, A. Sarlette, and P. Rouchon. Well-posedness and convergence of the Lindblad master equation for a quantum harmonic oscillator with multi-photon drive and damping. *ESAIM: COCV*, 22(4):1353 –1369, 2016.
- [10] A. Barchielli and M. Gregoratti. *Quantum Trajectories and Measurements in Continuous Time: the Diffusive Case*. Springer Verlag, 2009.
- [11] S. M. Barnett and P. M. Radmore. *Methods in Theoretical Quantum Optics*. Oxford University Press, 2003.
- [12] L. Baudoïn and J. Salomon. Constructive solution of a bilinear optimal control problem for a Schrödinger equation. *Systems and Control Letters*, 57:453–464, 2008.

- [13] V.P. Belavkin. Quantum stochastic calculus and quantum nonlinear filtering. *Journal of Multivariate Analysis*, 42(2):171–201, 1992.
- [14] G. Birkhoff. Extensions of Jentzsch’s theorem. *Trans. Amer. Math. Soc.*, 85:219–227, 1957.
- [15] B. Bonnard and M. Chyba. *Singular trajectories and their role in control theory*, volume 40. Springer; SMAI, 2003.
- [16] H.-P. Breuer and F. Petruccione. *The Theory of Open Quantum Systems*. Clarendon-Press, Oxford, 2006.
- [17] A.E. Bryson and Y.C. Ho. *Applied Optimal Control*. Ginn and Company, 1969.
- [18] P. Campagne-Ibarcq, S. Jezouin, N. Cottet, P. Six, L. Bretheau, F. Mallet, A. Sarlette, P. Rouchon, and B. Huard. Using spontaneous emission of a qubit as a resource for feedback control. *Phys. Rev. Lett.*, 117(6):060502, August 2016.
- [19] E. Cancès, C. Lebris, and M. Pilot. Contrôle optimal bilinéaire sur une équation de Schrödinger. *Comptes Rendus de l’Académie des Sciences, Paris, Série 1*, 330:567–571, 2000.
- [20] G. Cardona, A. Sarlette, and P. Rouchon. Exponential stochastic stabilization of a two-level quantum system via strict lyapunov control. In *2018 IEEE Conference on Decision and Control (CDC)*, pages 6591–6596, Dec 2018.
- [21] G. Cardona, A. Sarlette, and P. Rouchon. Exponential stabilization of quantum systems under continuous non-demolition measurements. *Automatica*, 112:108719, 2020.
- [22] H. Carmichael. *An Open Systems Approach to Quantum Optics*. Springer-Verlag, 1993.
- [23] H. Carmichael. *Statistical Methods in Quantum Optics 1: Master Equations and Fokker-Planck Equations*. Springer, 1999.
- [24] J. Carr. *Application of Center Manifold Theory*. Springer, 1981.
- [25] A. Chia and H. M. Wiseman. Quantum theory of MIMO Markovian feedback with diffusive measurements. *Phys. Rev. A*, 84:012120, Jul 2011.
- [26] C. Cohen-Tannoudji, B. Diu, and F. Laloë. *Mécanique Quantique*, volume I& II. Hermann, Paris, 1977.
- [27] J.M. Coron. *Control and Nonlinearity*. American Mathematical Society, 2007.
- [28] J. Dalibard, Y. Castin, and K. Mølmer. Wave-function approach to dissipative processes in quantum optics. *Phys. Rev. Lett.*, 68(5):580–583, February 1992.
- [29] E.B. Davies. *Quantum Theory of Open Systems*. Academic Press, 1976.
- [30] I. Dotsenko, M. Mirrahimi, M. Brune, S. Haroche, J.-M. Raimond, and P. Rouchon. Quantum feedback by discrete quantum non-demolition measurements: towards on-demand generation of photon-number states. *Phys. Rev. A*, 80: 013805-013813, 2009.

- [31] P. Duchêne and P. Rouchon. Kinetic scheme reduction via geometric singular perturbation techniques. *Chem. Eng. Science*, 51:4661–4672, 1996.
- [32] S. Ervedoza and J.-P. Puel. Approximate controllability for a system of Schrödinger equations modeling a single trapped ion. *Annales de l'Institut Henri Poincaré (C) Non Linear Analysis*, 26(6):2111 – 2136, 2009.
- [33] N. Fenichel. Geometric singular perturbation theory for ordinary differential equations. *J. Diff. Equations*, 31:53–98, 1979.
- [34] Jay Gambetta, Alexandre Blais, M. Boissonneault, A. A. Houck, D. I. Schuster, and S. M. Girvin. Quantum trajectory approach to circuit QED: Quantum jumps and the Zeno effect. *Phys. Rev. A*, 77(1):012112–, January 2008.
- [35] J. Guckenheimer and P. Holmes. *Nonlinear Oscillations, Dynamical Systems and Bifurcations of Vector Fields*. Springer, New York, 1983.
- [36] S. Haroche and J.M. Raimond. *Exploring the Quantum: Atoms, Cavities and Photons*. Oxford University Press, 2006.
- [37] E.T. Jaynes and F.W. Cummings. Comparison of quantum and semiclassical radiation theories with application to the beam maser. *Proceedings of the IEEE*, 51(1):89–109, 1963.
- [38] A. Kossakowski. On quantum statistical mechanics of non-Hamiltonian systems. *Reports on Mathematical Physics*, 3, 1972.
- [39] P. Kral, I. Thanopoulos, and M. Shapiro. Coherently controlled adiabatic passage. *Reviews Of Modern Physics*, 79(1):53–77, 2007.
- [40] H.J. Kushner. *Introduction to Stochastic Control*. Holt, Rinehart and Wilson, INC., 1971.
- [41] L. Landau and E. Lifshitz. *Mécanique*. Mir, Moscou, 4th edition, 1982.
- [42] C. Le Bris and P. Rouchon. Low-rank numerical approximations for high-dimensional Lindblad equations. *Phys. Rev. A*, 87(2):022125–, February 2013.
- [43] R. Lescanne, M. Villiers, Th. Peronnin, A. Sarlette, M. Delbecq, B. Huard, T. Kontos, M. Mirrahimi, and Z. Leghtas. Exponential suppression of bit-flips in a qubit encoded in an oscillator. *Nat. Phys.*, 16:509–513, 2020.
- [44] Weichao Liang, Nina H. Amini, and Paolo Mason. On exponential stabilization of spin 1/2 systems. In *2018 IEEE Conference on Decision and Control (CDC)*, pages 6602–6607, 2018.
- [45] Weichao Liang, Nina H. Amini, and Paolo Mason. On exponential stabilization of n -level quantum angular momentum systems. *SIAM Journal on Control and Optimization*, 57(6):3939–3960, 2019.
- [46] G. Lindblad. On the generators of quantum dynamical semigroups. *Communications in Mathematical Physics*, 48, 1976.

- [47] R.S. Liptser and A.N. Shiriyayev. *Statistics of Random Processes I General Theory*. Springer-Verlag, 1977.
- [48] M. Mirrahimi and R. Van Handel. Stabilizing feedback controls for quantum systems. *SIAM Journal on Control and Optimization*, 46(2):445–467, 2007.
- [49] M. Mirrahimi, Z. Leghtas, V.V. Albert, S. Touzard, R.J. Schoelkopf, L. Jiang, and M.H. Devoret. Dynamically protected cat-qubits: a new paradigm for universal quantum computation. *New Journal of Physics*, 16:045014, 2014.
- [50] M.A. Nielsen and I.L. Chuang. *Quantum Computation and Quantum Information*. Cambridge University Press, 2000.
- [51] D. Petz. Monotone metrics on matrix spaces. *Linear Algebra and its Applications*, 244:81–96, 1996.
- [52] D. Reeb, M. J. Kastoryano, and M. M. Wolf. Hilbert’s projective metric in quantum information theory. *Journal of Mathematical Physics*, 52(8):082201, August 2011.
- [53] P. Rouchon. Fidelity is a sub-martingale for discrete-time quantum filters. *IEEE Transactions on Automatic Control*, 56(11):2743–2747, 2011.
- [54] P. Rouchon. Models and Feedback Stabilization of Open Quantum Systems. In *Proceedings of International Congress of Mathematicians, volume IV*, pages 921–946, 2014. see also: <http://arxiv.org/abs/1407.7810>.
- [55] J.A. Sanders, F. Verhulst, and J. Murdock. *Averaging Methods in Nonlinear Dynamical Systems*. Springer, 2nd edition, 2007.
- [56] C. Sayrin, I. Dotsenko, X. Zhou, B. Peaudecerf, Th. Rybarczyk, S. Gleyzes, P. Rouchon, M. Mirrahimi, H. Amini, M. Brune, J.M. Raimond, and S. Haroche. Real-time quantum feedback prepares and stabilizes photon number states. *Nature*, 477:73–77, 2011.
- [57] R. Sepulchre, A. Sarlette, and P. Rouchon. Consensus in non-commutative spaces. In *Decision and Control (CDC), 2010 49th IEEE Conference on*, pages 6596–6601, 2010.
- [58] A. Shapere and F. Wilczek. *Geometric Phases in Physics*. Advanced Series in Mathematical Physics-Vol.5, World Scientific, 1989.
- [59] A. Somaraju, I. Dotsenko, C. Sayrin, and P. Rouchon. Design and stability of discrete-time quantum filters with measurement imperfections. In *American Control Conference (ACC)*, pages 5084–5089, 2012.
- [60] A. Somaraju, M. Mirrahimi, and P. Rouchon. Approximate stabilization of an infinite dimensional quantum stochastic system. *Rev. Math. Phys.*, 25(01):1350001–, January 2013.
- [61] D. Tannor, V. Kazakov, and V. Orlov. *Time Dependent Quantum Molecular Dynamics*, chapter Control of photochemical branching: Novel procedures for finding optimal pulses and global upper bounds, pages 347–360. Plenum, 1992.
- [62] V.E. Tarasov. *Quantum Mechanics of Non-Hamiltonian and Dissipative Systems*. Elsevier, 2008.

- [63] S. Teufel. *Adiabatic Perturbation Theory in Quantum Dynamics*. Lecture notes in Mathematics, Springer, 2003.
- [64] A. Tikhonov, A. Vasil'eva, and A. Sveshnikov. *Differential Equations*. Springer, New York, 1980.
- [65] K. Tsumura. Global stabilization of n-dimensional quantum spin systems via continuous feedback. In *American Control Conference (ACC07)*, pages 2129–2134, July 2007.
- [66] R. van Handel. *Filtering, Stability, and Robustness*. PhD thesis, California Institute of Technology, 2007.
- [67] R. van Handel. The stability of quantum Markov filters. *Infin. Dimens. Anal. Quantum Probab. Relat. Top.*, 12:153–172, 2009.
- [68] H. M. Wiseman, S. Mancini, and J. Wang. Bayesian feedback versus Markovian feedback in a two-level atom. *Phys. Rev. A*, 66:013807, Jul 2002.
- [69] H.M. Wiseman. Quantum theory of continuous feedback. *Physical Review A*, 49:2133–50, 1994.
- [70] H.M. Wiseman. *Quantum Trajectories and Feedback*. PhD thesis, University of Queensland, 1994.
- [71] H.M. Wiseman and G.J. Milburn. *Quantum Measurement and Control*. Cambridge University Press, 2009.
- [72] L. P. Yatsenko, S. Guérin, and H. R. Jauslin. Topology of adiabatic passage. *Phys. Rev. A*, 65(043407), 2002.
- [73] W. Zhu and H. Rabitz. A rapid monotonically convergent algorithm for quantum optimal control over the expectation value of a definite operator. *J. Chem. Phys.*, 109:385–391, 1998.